

# Industrial Hoses

Catalogue





# Detailed table of Contents

Alphabetical Index	IV
Index by Application	V
Partnumber Index	VI

## Promotional pages

Global hose	13
Silicone Hose	14
E-Z Form	14
Barrier Hose	15
POLIAX range	15
GAMBRINUS range	16
Low Temperature Hose	17

## Technical Handbook





































































Hose Selection Matrix	TH4
Hose Part Number Description	TH8
Parker Safety Guide	TH37

## Hose Technical Specification

























 Oil & Fuel	A
 Automotive	B
 Gas	C
 Water	D
 Hot Water & Steam	E
 Acid & Chemicals	F
 Material Handling	G
 Beverage & Food	H
 Multipurpose & Air	I

We reserve the right to modify whenever necessary the features and specifications of the products included in this publication without prior notice.

















# Alphabetical Index

<b>A</b>	<b>Page</b>	<b>I</b>	<b>Page</b>	<b>T</b>	<b>Page</b>
 AIRBRAKE DIN 74310	B8	 IDRO 10	D6	 TBE	B11
 APERFRUT 20	I14	 INTONACATRICI 40	G5	 TBSE	B10
 APERFRUT 40	I14	<b>J</b>	<b>Page</b>	 THERMOPRESS 10	E7
 APERFRUT 80	I14	 JUMBO N/L	I10	<b>V</b>	<b>Page</b>
 APERSPIR	H10	<b>L</b>	<b>Page</b>	 VIGOR 2 EN ISO 6134 TYPE 2/A	E8
 ASPIREX	G8	 LIBECCIO EN ISO 3861	G4	 VIGOR 2 NR EN ISO 6134 TYPE 2/A	E8
 AUTOGENE EN ISO 3821 NR/L - NB/L 20	C4	<b>M</b>	<b>Page</b>	 VINITRESS	H9
<b>B</b>	<b>Page</b>	 MINIERA 20 MSHA	I11	<b>W</b>	<b>Page</b>
 BETON 80	G6	 MULTIREX	D8	 WAVEMASTER™	B13
 BEVERA 10	D7	<b>O</b>	<b>Page</b>		
<b>C</b>	<b>Page</b>	 OILPRESS N/L 20	I13		
 CARBO G NW/L 10 - NB/R 10	C6	 OILPRESS N/L 30	I13		
 CARBOBLUE N/L 10	B12	<b>P</b>	<b>Page</b>		
 CARBOBLUE N/L 20	B12	 POLIAX D EN 12115	F4		
 CARBOCORD EN 12115	A6	 POLIAX D SM EN 12115	F5		
 CARBOPRESS N/L 10	A4	 POLIAX F EN 12115	F8		
 CARBOPRESS N/L 20	A4	 POLIAX PHARMA	F9		
 CARBURITE 10	A5	 POLIAX UPE CON SM EN 12115	F6		
 CERGOM	G7	 POLIAX UPE CON SM EN 12115 OND	F7		
 CERVINO EN 12115	A8	 PRESCORD N/R 10	D5		
 CHEMIOEL EN 12115	A7	 PROPANPRESS EN ISO 3821 N/A/L 20	C5		
<b>D</b>	<b>Page</b>	 PYTHON N/L 20	I7		
 DRINKPRESS WB/L 10	H4	 PYTHON NV/L 20	I8		
<b>E</b>	<b>Page</b>	 PYTHON NY/L 30	I9		
 ENOREX	H11	<b>R</b>	<b>Page</b>		
 E-Z FORM™ GS	B5	 RADIOR 10	B4		
 E-Z FORM™ HT	A9	 RADIOR 3 (COIL)	E4		
 E-Z FORM™ MP	I12	 RADIOR 3 (CUT LENGTH)	E5		
<b>F</b>	<b>Page</b>	 RADIOR DIN 6	B6		
 FUCINO 20	D4	 RADIOR K 1003	E6		
<b>G</b>	<b>Page</b>	<b>S</b>	<b>Page</b>		
 GAMBRINUS BLUE 10	H6	 SERIES 395 SAE J 30R7	B9		
 GAMBRINUS BLUE SM 10	H7	 SERIES 6722	B7		
 GAMBRINUS RED SM 10	H8	 SM/TR 311	B14		
 GAMBRINUS UPE SM EN12115	H5	 SUPER-FLEX® FL	B16		
 GST II BLACK 15	I4	 SUPER-FLEX® FL-7	B15		
 GST II BLACK 20	I6				
 GST II RED 15	I5				



























# Index by Application

A – Oil & Fuel		B – Automotive & Boat		C – Gas	
	Page		Page		Page
 CARBOPRESS N/L 10	A4	 RADIOR 10	B4	 AUTOGENE EN ISO 3821 NR/L – NB/L 20	C4
 CARBOPRESS N/L 20	A4	 E-Z FORM™ GS	B5	 PROPANPRESS EN ISO 3821 NAL 20	C5
 CARBURITE 10	A5	 RADIOR DIN 6	B6	 CARBO G NW/L 10 – NB/R 10	C6
 CARBOCORD EN 12115	A6	 SERIES 6722	B7		
 CHEMOEL EN 12115	A7	 AIRBRAKE DIN 74310	B8		
 CERVINO EN 12115	A8	 SERIES 395 SAE J 30R7	B9		
 E-Z FORM™ HT	A9	 TBSE	B10		
		 TBE	B11		
		 CARBOBLUE N/L 10	B12		
		 CARBOBLUE N/L 20	B12		
		 WAVEMASTER™	B13		
		 SM/TR 311	B14		
		 SUPER-FLEX® FL-7	B15		
		 SUPER-FLEX® FL	B16		

D – Water		E – Hot Water & Steam		F – Acid & Chemicals	
	Page		Page		Page
 FUCINO 20	D4	 RADIOR 3	E4 E5	 POLIAX D EN 12115	F4
 PRESCORD N/R 10	D5	 RADIOR K 1003	E6	 POLIAX D SM EN 12115	F5
 IDRO 10	D6	 THERMOPRESS 10	E7	 POLIAX UPE CON SM EN 12115	F6
 BEVERA 10	D7	 VIGOR 2 EN ISO 6134 TYPE 2/A	E8	 POLIAX UPE CON SM EN 12115 OND	F7
 MULTIREX	D8	 VIGOR 2 NR EN ISO 6134 TYPE 2/A	E8	 POLIAX F EN 12115	F8
				 POLIAX PHARMA	F9











  

G – Material Handling		H – Beverage & Food		I – Multipurpose & Air	
	Page		Page		Page
 LIBECCIO EN ISO 3861	G4	 DRINKPRESS WB/L 10	H4	 GST II BLACK 15	I4
 INTONACATRICI 40	G5	 GAMBRINUS UPE SM EN12115	H5	 GST II RED 15	I5
 BETON 80	G6	 GAMBRINUS BLUE 10	H6	 GST II BLACK 20	I6
 CERGOM	G7	 GAMBRINUS BLUE SM 10	H7	 PYTHON N/L 20	I7
 ASPIREX	G8	 GAMBRINUS RED SM 10	H8	 PYTHON NV/L 20	I8
		 VINITRESS	H9	 PYTHON NY/L 30	I9
		 APERSPIR	H10	 JUMBO N/L	I10
		 ENOREX	H11	 MINIERA 20 MSHA	I11
				 E-Z FORM™ MP	I12
				 OILPRESS N/L 20	I13
				 OILPRESS N/L 30	I13
				 APERFRUT 20	I14
				 APERFRUT 40	I14
				 APERFRUT 80	I14

# Partnumber Index

Partnumber (IH+6 digits)	Hose	page
IH110013	TBE	B11
IH301121	PRESCORD N/R 10	D5
IH301140	RADIOR 10	B4
IH301160	PRESCORD N/R 10	D5
IH301165	JUMBO N/L	I10
IH302400	DRINKPRESS WB/L 10	H4
IH303151	AIRBRAKE DIN 74310	B8
IH303512	PYTHON N/L 20	I7
	PYTHON NV/L 20	I8
	PYTHON NY/L 30	I9
IH304127	AUTOGENE EN ISO 3821 NR/L - NB/L 20	C4
IH304128	AUTOGENE EN ISO 3821 NR/L - NB/L 20	C4
IH304129	AUTOGENE EN ISO 3821 NR/L - NB/L 20	C4
IH304132	AUTOGENE EN ISO 3821 NR/L - NB/L 20	C4
IH304134	PROPANPRESS EN ISO 3821 NA/L 20	C5
IH305010	CARBOPRESS N/L 10 - 20	A4
IH305020	CARBOPRESS N/L 10 - 20	A4
IH305110	CARBOPRESS N/L 10 - 20	A4
IH305120	CARBOPRESS N/L 10 - 20	A4
IH305150	CARBOBLUE N/L 10 - 20	B12
IH305515	CARBO G NW/L 10 - NB/R 10	C6
IH305516	CARBO G NW/L 10 - NB/R 10	C6
IH308313	RADIOR K 1003	E6
IH308320	OILPRESS N/L 20 - 30	I13
IH308361	RADIOR DIN 6	B6
IH308710	TBSE	B10
395	SERIES 395 SAE J 30R7	B9
IH350332	VINITRESS	H9
IH350400	APERFRUT 20 - 40 - 80	I14
IH350401	APERFRUT 20 - 40 - 80	I14
IH350402	APERFRUT 20 - 40 - 80	I14
IH355600	ASPIREX	G8
IH355601	ASPIREX	G8
IH355602	ASPIREX	G8
IH355620	ASPIREX	G8
IH355621	ASPIREX	G8
IH356000	MULTIREX	D8
IH356001	MULTIREX	D8
IH356020	MULTIREX	D8
IH356021	MULTIREX	D8
IH356200	ENOREX	H11

Partnumber (IH+6 digits)	Hose	page
IH356201	ENOREX	H11
IH356410	APERSPIR	H10
IH356411	APERSPIR	H10
IH362030	IDRO 10	D6
IH362031	IDRO 10	D6
IH362032	FUCINO 20	D4
IH362110	BEVERA 10	D7
IH362140	BEVERA 10	D7
IH362423	GAMBRINUS UPE SM EN12115	H5
IH362424	GAMBRINUS BLUE 10	H6
	GAMBRINUS BLUE SM 10	H7
IH362425	GAMBRINUS RED SM 10	H8
IH363421	MINIERA 20 MSHA	I11
IH363512	PYTHON N/L 20	I7
	PYTHON NV/L 20	I8
	PYTHON NY/L 30	I9
IH365223	CARBOCORD EN 12115	A6
IH365300	CARBURITE 10	A5
IH365302	CARBURITE 10	A5
	CHEMIOEL EN 12115	A7
IH365304	CERVINO EN 12115	A8
IH365310	CARBURITE 10	A5
IH368000	THERMOPRESS 10	E7
IH368017	VIGOR 2 NR EN ISO 6134 TYPE 2/A	E8
IH368101	POLIAX D EN 12115	F4
	POLIAX D SM EN 12115	F5
IH368115	POLIAX F EN 12115	F8
	POLIAX PHARMA	F9
	POLIAX UPE CON SM EN 12115	F6
	POLIAX UPE CON SM EN 12115 OND	F7
IH368202	LIBECCIO EN ISO 3861	G4
IH368203	LIBECCIO EN ISO 3861	G4
IH368220	INTONACATRICI 40	G5
IH368270	BEVERA 10	D7
IH368290	CERGOM	G7
IH368300	RADIOR 3 (COIL)	E4
	RADIOR 3 (CUT LENGTH)	E5
IH368301	RADIOR 3 (COIL)	E4
IH368310	RADIOR 3 (COIL)	E4
	RADIOR 3 (CUT LENGTH)	E5
IH368361	RADIOR DIN 6	B6

Partnumber (IH+6 digits)	Hose	page
IH369710	 SM/TR 311	B14
389	 SUPER-FLEX® FL-7	B15
397	 SUPER-FLEX® FL	B16
6722	 SERIES 6722	B7
IH7092	 GST II RED 15	I5
IH7093	 GST II BLACK 15	I4
	 GST II BLACK 20	I6
7165	 WAVEMASTER™	B13
IH7219	 E-Z FORM™ MP	I12
IH7395	 E-Z FORM™ GS	B5
7399	 E-Z FORM™ HT	A9

## Service – Helpdesk

An expert team of sales and customer service specialists are at your disposal, assuring proficient support and appropriate problem solving resources. Parker provides personal sales and technical support through local branch sales representatives as well as regional industrial hose sales specialists, product sales managers and engineers. We care about your business and seek to develop a close relationship with you.



# PARKER HANNIFIN – THE GLOBAL LEADER AND YOUR PARTNER

Parker Hannifin is the world's leading diversified manufacturer of motion and control technologies and systems, providing precision-engineered solutions for a wide variety of mobile, industrial and aerospace markets. Our products are vital to virtually everything that moves or requires control, including the manufacture and processing of raw materials, durable goods, infrastructure development and all forms of transport.

Our engineering expertise spans the core motion and control technologies – electromechanical, hydraulic and pneumatic – as well as a full complement of fluid control systems; software and electronic controls; filtration systems; and refrigeration, instrumentation and sealing technologies.

## Dry Technology

The leader in “dry technology” for the fluid power industry, Parker's Fluid Connectors Group is your single source for high-quality tube fittings, hose and hose fittings, thermoplastic tubing, brass fittings and valves, quickdisconnect couplings and assembly tools.

## Markets

The Fluid Connectors Group serves customers in a broad range of markets, including Aerial Lift, Agriculture, Bulk Chemical Handling, Construction Machinery, Food & Beverage, Fuel & Gas Delivery, Industrial Machinery, Medical, Mining, Mobile, Oil & Gas and Transportation.

## Customer Services

Products are available for shipment 24 hours a day, supported by 50 manufacturing facilities throughout the world and a global distribution network. Our commitment to you is impeccable customer service. To meet your specific requirements, we offer a broad range of programs designed to reduce your overall operating costs, streamline manufacturing, improve productivity, manage inventory, enhance delivery and address safety and environmental issues. For value-added services that generate value-added solutions, team up with Parker!



# PARKER HANNIFIN – OPPORTUNITY THROUGH INNOVATION IN THE WORLD’S MOST DEMANDING MARKETS



## Worldwide availability

With more than 55,000 employees serving our valued customers in almost 50 countries, Parker is literally everywhere you need us to be. By working with us, you have access to an integrated network of 336 manufacturing plants, as well as 13,200 distributors and MRO outlets, and over 2,200 ParkerStores™. That’s the kind of global network for global businesses demand.

## Flexibility

As the world’s motion control expert, Parker offers you a complete range of proven, off-the-shelf products. These products deliver exceptional quality and durability, reducing costs and advancing performance.

## Innovation

It’s what drives us. Our mandate for continuous improvement leads us to partner with our customers to create solutions that are smaller, lighter, sustainable, more energy efficient, and highly reliable.

## Hose Products Division Europe –

Performing solutions for every market and application wherever they are

Parker industrial hose products are the preferred choice across diverse applications, industries and markets. Whether the need is for durable rubber, lightweight and flexible composite, abrasion resistant PVC or extreme temperature silicone hose, Parker has the right hose for your job. We offer a wide variety of hose construction options, materials and performance criteria.

Parker hoses are designed, built and supplied globally for long-lasting performance and superior value, and have earned a reputation for excellence in agriculture, construction, petrochemical, transportation and many other markets.

We supply a variety of hoses suitable for multiple media: standard hoses for traditional service as well as heavy duty hoses that provide superior resistance to abra-

sion, oils, chemicals, heat, flame and cold. We have the ability and expertise to safely handle either hazardous media in harsh environment and valuable and delicate media in protected environment.

From design, development and production to stocked inventory and shipment; we apply our know how and passion to provide our customers with solid and efficacious solutions.



## Our History of Experience

With our history of success and reputation as a world-class manufacturer of flexible rubber hose, we continue to pursue and develop technologies offering the best solution for every application. Recent activities includes: Pelican hose assembly for bunkering application in ports and docks, introduction of innovative products such as ultra-flexible E-Z Form hose, development of the breakthrough technology such as extremely abrasion resistant

CERGOM material handling hose, and special application hoses Carboblue. The latter hoses are environmentally friendly, providing the required high grade of cleanliness for the SRC technology reducing NOx emission. Our success stories include a number of global OEMs and distributors across many diverse industries. We contribute to short-and long-term customer profitability by maximizing value through premier product quality and service.

## Capabilities

Our manufacturing process is supported by a highly qualified and experienced engineering staff and efficient production equipment. Deployment of these resources ensures precision control of the manufacturing process and materials, as well as the ability to create new design ideas and implement solutions. Now we have introduced into our range new materials such as silicone and PTFE to further meet customers' expectations and be more active in the industrial and chemical market segments.

Production line	ID min (mm)	ID max (mm)
Long Length	3	38
Mandrel Made	13	200
PVC	5	300
Thermoplastic	5	75
Silicone	13	51
Custom Made	51	610

## Quality

Parker is a company which operates in compliance with the quality system laid down by the UNI EN ISO 9001 and 14001 standard, certified by Bureau Veritas. More and more Parker industrial hoses are certified by the main international certification bodies.



## Ecology



Caring for and ensuring the sustainability of the planet is our intention; we therefore develop and improve hoses for alternative fuels like gas, natural oils, ester oils etc. for environmentally friendly technologies such as the new SCR one. Parker developed nitrosamine-free compounds to improve the quality of life and of the environment.

We are doing more for our customers than ever before. Globally, we have localized service to provide fast, hassle-free responses and on-site support. We're staying close to our customers and integrating systems to help them become more profitable. We are committed to delivering our highly engineered products on-time, on-promise.

## Compounds

Our R&D team invests significant resources in the development of new and improved rubber compounds. The recipes are formulated according to the final

application of the hose, guaranteeing the utmost performance of the inner tube and cover. An efficient technical center makes it possible to test and study the properties and

behavior of different ingredients in order to identify and solve possible critical problems. All aspects of compounds development and production – from design to testing to manufacturing – are constantly in compliance with main relevant international standards.

Modern testing equipment allows us to check the product during any stage of the process.

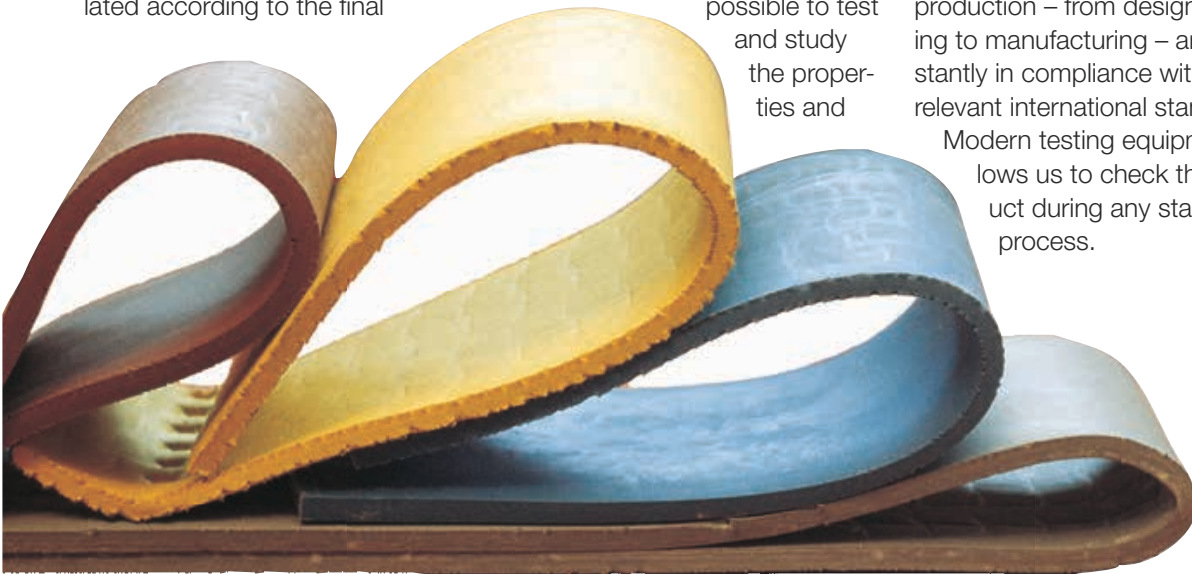

## Oil & Fuel Hose Pelican EN 1765 type S15

Pelican Hose is specially designed for bunkering operations. It is the activity for the loading, discharging and transferring of fuels between a bunker barge, a marine terminal or a marine facility from/ to a receiving ship. Bunkering operations needs to be performed diligently, safely with all necessary measures in place to prevent fuel spillage into the waters of the Port or onto the quayside. It is thus fundamental to have solid and reliable components aligned with the international industry standards. Pelican is recommended in

combination with Parker large bore crimped fittings range specifically designed for its structure and sold in customized length assemblies. Please contact our Customer Service Helpdesk in your local Parker location.

Supplied and tested with end crimped fittings enables a significant time reduction compared to traditional solution with vulcanized couplings optimizing the operability of end user. Parker Pelican hose assemblies are available conductive or discontinuous based on the individual application.

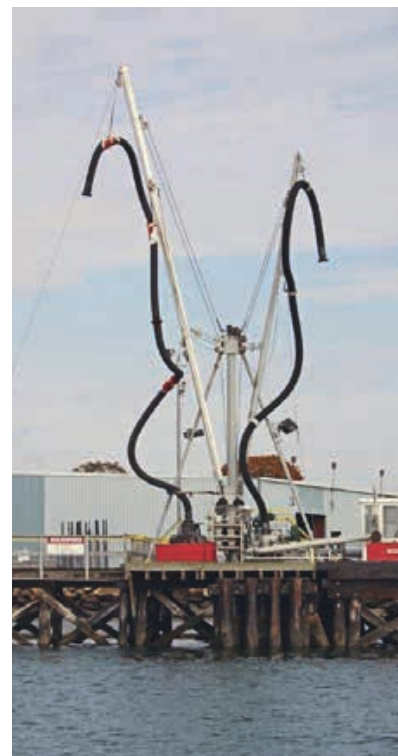

# Material Handling Transfer Hose – CERGOM

CERGOM is manufactured and patented based on a unique hose technology for pneumatic delivery and vacuum conveying systems of abrasive materials.

The hose is constructed in a combination of a new tube material with ceramic hexagonal plates. With the added benefit of the ultra high abrasion resistance, the hose has an increased service life in comparison to elastomer hoses qualities and rigid tubes and therefore the maintenance cost and machine shut downs will be reduced to a minimum. Together with the respective fitting range (swivel flanges) CERGOM is ideal for tough environments such as

steelworks, thermoelectric power plants, cement works, mining industry etc. CERGOM hose assemblies are very flexible in use with different working conditions and easier to handle than rigid elbows. Based on its construction, CERGOM hose assemblies

minimize significantly the vibration and noise during operation solving the toughest challenges for abrasive material handling.

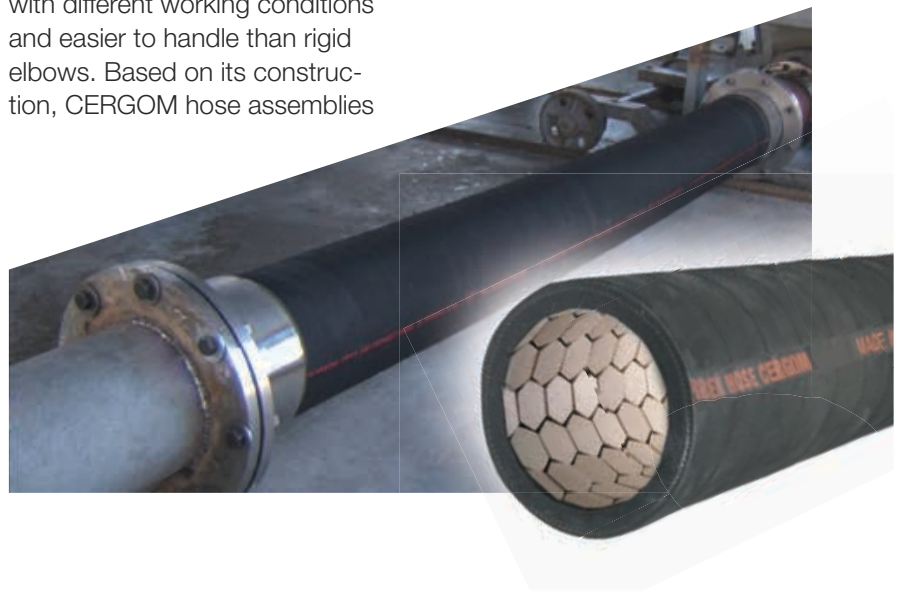

## Global Hose

Same hose, same performance, same features, same availability everywhere

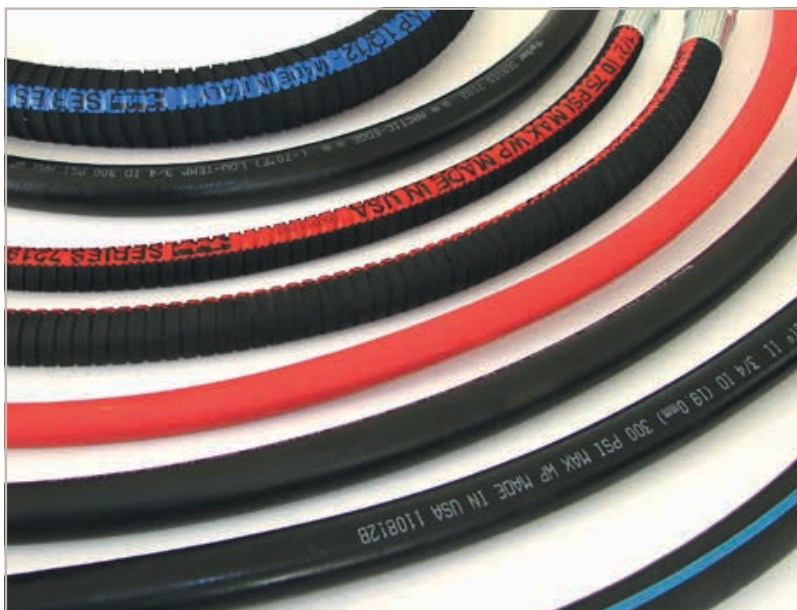

Our Global Hose Program consists of a worldwide network of Parker manufacturing facilities and distribution centers that assure consistent Parker quality while providing the flexibility to satisfy peaks of customer demand. The synergy among Industrial hose divisions around the world is one of our primary strength and an value-added support for our customers. Parker global hoses are suitable for OEMs and MRO channels, for diverse application across multiple industries and markets.

## Silicone Hose

Silicone rubber hose is the ultimate choice for those extreme-temperature application.

Silicone has a number of chemical and mechanical and offers benefits for designers and users such as: improved performance over the long haul; flexibility while retaining their shape for installation in tight envelopes or around obstructions; low permeation to reduce or eliminate emissions, odors. Last but not least, it can be truly sterilized to ensure purity of products being manufactured or processed.

We offer solution either for cooling in industrial or transportation application (series 6722) and in the food, pharmaceutical and chemical industry (series Poliax Pharma)

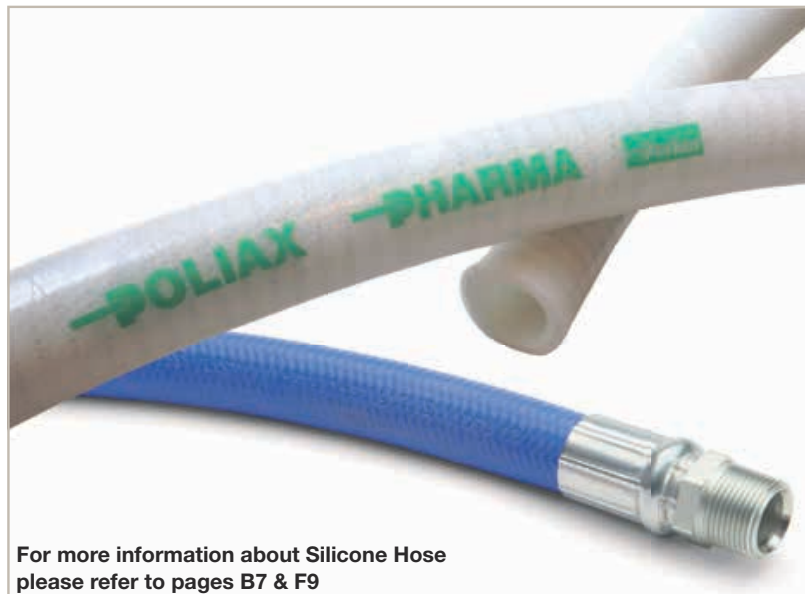

For more information about Silicone Hose please refer to pages B7 & F9

## GAMBRINUS range

Rubber and PVC hose range specifically designed for food & beverage industry to efficiently and safely convey all foodstuff while preserving products features and consumer health.



For more information about the new GAMBRINUS range please refer to pages H5 - H8

The program includes specific alimentary hoses to withstand and preserve different typologies of foodstuff during the collecting, transport and processing phases. Produced on dedicated lines using stainless steel mandrels, our compounds are resistant to cleaning and sterilization to guarantee utmost hygienic standard. Each GAMBRINUS line is designed to fit specific products features. Specifically for tank lorries application we added the Gambrinus Anti Crash with a PET helix able to recover its shape

after accidental squeeze. The appropriate manufacturing and performance standards are certified by compliance with main European and International norms and specs such as EC 1935, BfR XXI, FDA. We also offer Stainless Steel Fittings capabilities – with permanently crimping ferrule or safety/bolt clamps – providing solutions to the most demanding applications in process plants. Our offering is supplemented with PVC hoses that offer an alternative to rubber where lighter weight is preferred.

## E-Z Form Hose

Kink-free E-Z Form™ Hose  
Eliminates the Need for Pre-formed Hose



E-Z Form hose provides extreme flexibility for easy and quick installation of coolant, water and oil suction/return lines on mobile and industrial equipment. Available in multiple incremental sizes, E-Z Form hose reduces installation time, eliminates the need for costly made-to-order pre-formed hose and provides rapid delivery from stock without requiring dedicated inventory.

The offer has been extended to a High Temperature version, designed to resist cracking and deterioration from the extreme heat generated by engine compartments of buses, cranes, trucks and mobile/heavy-duty off-road equipment. It may also be used in non-SAE power steering return line applications.

## Barrier Hose

Fuel, Vapor and Coolant/Heater Hoses

Parker offers a package of durable, flexible and lightweight hoses to handle virtually every engine-related requirement, including fuel supply, vapor emission and cooling. These can be used in multiple market segments such as agriculture, off-roads, marine and transportation. They are designed to comply with the main international standards (ISO, SAE) and offer a superior low permeability rate for a higher protection of components and users. Compatible with biodiesel, diesel, ethanol and gasoline.



## POLIAX range

Hoses manufactured with state-of-the-art compounds according to European standards to transfer chemicals, corrosive products and additives in mobile or fixed installations.

Extreme chemical transfer applications do not scare us; on the contrary it is part of our mission and a commitment. Our Poliax product line inhibits the contamination of the environment and guarantees the integrity of the media conveyed. The hose meets or exceeds EN 12115 specifications. We have multiple construction typologies to suits as many needs as possible and the range has been extended to new materials silicone and PTFE to withstand higher temperatures and aggressive fluid concentration.

The corrugated version offers additional flexibility and it is easy to handle in case of routing constraints or manual operations. Due to many different media combinations of acids, solvents, alkalis - and an infinite variety of possible combinations - we recommend to utilize the STAMP approach and always consult our chemical compatibility chart to select the most appropriate hose. If there are any doubts or question, contact a Parker engineer.

**For more information about the POLIAX range please refer to chapter F (Acid & Chemicals)**



## Industrial Hose Fittings

Your industrial application requires quality fittings that meet regulatory standards and outperform your expectations. Parker is up for the challenge with a variety of fittings with different end-configurations and geometry to meet all of your application needs.

We have tested and approved all offered fitting series for your application to enhance reliability and performance.

You can rely on Parker fitting series one-piece 48 series, two-piece 47 series with shell 10064 and IF series for large bore hoses









# Industrial Hoses

Technical Handbook





# Technical Handbook

<b>Technical Handbook</b>	TH3
<b>Hose Selection Matrix</b>	TH4
<b>Rubber Hose Construction</b>	TH6
<b>PVC Hose Construction</b>	TH7
<b>Hose Part Number Description</b>	TH8
<b>Conversion Chart</b>	TH9
<b>Before you spec it, STAMP it.</b>	TH10 – TH11
<b>Standards</b>	TH12
<b>Guideline to Use and Cleaning of Food and Pharma Hose</b>	TH13
<b>Oil and Fuel Compatibility</b>	TH14
<b>Conductive Value Table</b>	TH15
<b>Properties of Basic Rubber Compounds</b>	TH16
<b>Chemical Resistance Table</b>	TH17 – TH32
<b>Chemical Resistance Guide for Silicone Hose</b>	TH33
<b>Rubber Hose Dimensional Tolerances</b> – According to norms	TH34
<b>PVC Hose Dimensional Tolerances</b>	TH34
<b>Parker Safety Guide</b>	TH35 – TH40
<b>Critical Applications</b>	TH39 – TH42

Technical Handbook

# Hose Selection Matrix

Hose	ID Range (mm)	Temp. Range (°C)	Application	Tube	Reinforcement	Cover	WP (bar)	De-sign factor	Sec-tion	Industry standard	Page
<b>Oil &amp; Fuel</b>											
CARBOPRESS M/L 10	5 - 25	-25 / +80	fuel, oil, petrol aromatic < 50 %	NBR	textile	NBR/EPDM	10	3			A4
CARBOPRESS M/L 20	6 - 25	-25 / +80	fuel, oil, petrol aromatic < 50 %	NBR	textile	NBR/EPDM	20	3			A4
CARBURITE 10	19 - 150	-30 / +80	fuel, oil, petrol aromatic < 50 %	NBR	textile	NBR/SBR	10	3	yes		A5
CARBOCORD EN 12115	19 - 100	-25 / +80	fuel, oil, petrol aromatic < 50 %	NBR	textile + copper wires	NBR/SBR	16	4		EN 12115	A6
CHEMIOEL EN 12115	19 - 100	-25 / +80	fuel, oil, petrol aromatic < 50 %	NBR	textile + copper wires	NBR/SBR	16	4	yes	EN 12115	A7
CERVINO EN 12115	50 - 100	-40 / +80	fuel, oil, petrol aromatic < 50 %	NBR	textile + copper wires	NBR/SBR	16	4	yes	EN 12115	A8
E-Z FORM™ HT	12.7 - 25.4	-40 / +150	petroleum-based oil	CPE	textile	NBR	10	4	yes		A9
<b>Automotive &amp; Boat</b>											
RADIOR 10	7 - 15	-30 / +100	cooling line system	EPDM	textile	EPDM	10	3			B4
E-Z FORM™ GS	12.7 - 102	-45 / +125	high flexible hose for coolant line system	EPDM	textile	EPDM	5	4	yes	SAE J 20R2 - D1	B5
RADIOR DIN 6	10 - 50	-40 / +125	cooling line system	EPDM	textile	EPDM	6	3			B6
Series 6722	6 - 25	-54 / +177	Heater and cooling line system	SILICONE	textile	SILICONE	5.7	3		SAE J20R3 Class A	B7
AIRBRAKE DIN 74310	9 - 13	-40 / +70	breaking system	EPDM	textile	EPDM	10	4		DIN 74310	B8
Series 395 SAE J 30R7	4.8 - 12.7	-40 / +125	car & motorbike fuel system	NBR	textile	CR	2.4/5.2	5		SAE 30 R7	B9
TBSE	4 - 10	-30 / +100	car & motorbike fuel system	NBR	textile	NBR/EPDM	10	3			B10
TBE	3 - 7.5	-20 / +90	car & motorbike fuel system	NBR	textile		10	3			B11
CARBOLUE N/L 10	16 - 25	-40 / +100	nox reducing system	EPDM	textile	EPDM	10	3			B12
CARBOLUE N/L 20	6 - 25	-40 / +100	nox reducing system	EPDM	textile	EPDM	20	3			B12
WAVEMASTER™	6.3 - 19	-29 / +100	marine barrier fuel hose	NYLON	textile	NBR/PVC	7	4	light	Refer to the page	B13
SM/TR 311	19 - 50	-20 / +80	coolant line	NBR	textile	NBR/CR	3	> 3.5	yes	EN ISO 7840 A1	B14
SUPER-FLEX® FL-7	4.7 - 19.1	-40 / +125	low permeation fuel hose	NBR/THV	textile	CPE	6.9	5	light	SAE J30R7/J30R14T2	B15
SUPER-FLEX® FL	4.7 - 15.9	-30 / +125	low permeation fuel hose	NBR/barrier	textile	CPE	6.9	5	light	AEJ30R7/J30R14T2	B16
<b>Gas</b>											
AUTOGENE EN ISO 3821 NPL - NBL 20	6.3 - 10	-25 / +80	welding process	EPDM/SBR	textile	EPDM	20	3		EN ISO 3821	C4
PROPANPRESS EN ISO 3821 NAL 20	6.3 - 10	-30 / +70	propan gas delivery	NBR/NR	textile	EPDM	20	3		EN ISO 3821	C5
CARBO G NW/L 10 - NBR 10	8 - 13	-20 / +90	household appliances	NBR	textile	EPDM	10	3		UNI CIG 7140	C6
<b>Water</b>											
FUCINO 20	50 - 120	-30 / +80	water, non aggressive liquids	SBR	textile	SBR	20	3			D4
PRESCORD N/R 10	8 - 25	-30 / +80	water, non aggressive liquids	SBR	textile	SBR/EPDM	10	3			D5
IDRO 10	25 - 75	-30 / +80	water, non aggressive liquids	SBR	textile	SBR	10	3			D6
BEVERA 10	19 - 203	-30 / +80	water, non aggressive liquids	SBR	textile	SBR	10	3	yes		D7
MULTIREX	19 - 150	-10 / +60	water, non aggressive liquids	PVC	PVC wire	PVC	7	3	yes		D8
<b>Hot Water &amp; Steam</b>											
RADIOR 3	10 - 100	-40 / +100	cooling line system	EPDM	textile	EPDM	3	3			E4-E5
RADIOR K 1003	12 - 65	-40 / +100	cooling line system	NBR	textile	CR	5	3			E6
THERMOPRESS 10	12 - 60	-40 / +100	cooling line and hot water	EPDM	textile	EPDM	10	4			E7
VIGOR 2 EN ISO 6134 Type 2/A	13 - 51	-40 / +210	steam industrial application	EPDM	textile	EPDM	18	10		EN ISO 6134 Type 2/A	E8
VIGOR 2 NR EN ISO 6134 Type 2/A	13 - 51	-40 / +210	steam industrial application	EPDM	textile	EPDM	18	10		EN ISO 6134 Type 2/A	E8

••• ISO 7840, ABYC, CARB, CE, EPA, NMMA, SAE J1527 A1-15, USCG A1 •••

Hose	ID Range (mm)	Temp. Range (°C)	Application	Tube	Reinforcement	Cover	WP (bar)	De-sign factor	Suc-tion	Industry standard	Page
<b>Acid &amp; Chemicals</b>											
POLIAJX D EN 12115	19 - 100	-35 / +100	chemical resistance table	EPM	textile + copper wires	EPDM	16	4		EN 12115	F4
POLIAJX D SM EN 12115	19 - 100	-35 / +100	chemical resistance table	EPM	textile + copper wires	EPDM	16	4	yes	EN 12115	F5
POLIAJX UPE CON SM EN 12115	19 - 100	-20 / +100	chemical resistance table	UHMWPE	textile + copper wires	EPDM	16	4	yes	EN 12115	F6
POLIAJX UPE CON SM EN 12115 OND	19 - 100	-20 / +100	chemical resistance table	UHMWPE	textile + copper wires	EPDM	16	4	yes	EN 12115	F7
POLIAJX F EN 12115	13 - 75	-40 / +150	chemical resistance table	PTFE	textile + copper wires	EPDM	16	4	yes	EN 12115	F8
POLIAJX PHARMA	13 - 51	-60 / +200	chemical resistance table	SILICONE	textile + copper wires	SILICONE	6/15	3	yes		F9
<b>Material Handling</b>											
LIBECCIO EN ISO 3861	19 - 100	-30 / +70	wet and dry sand and cement	BR/NBR	textile	SBR/NBR	10	4		EN ISO 3861	G4
INTONACATRICI 40	25 - 65	-30 / +70	wet and dry sand and cement	BR/NBR	textile	SBR	40	3			G5
BETON 80	51 - 125	-40 / +70	high pressure concrete pumping	NP/SBR	steel wire	NP/SBR	80	2,5			G6
CERGOM	25 - 200	-30 / +70	high abrasive materials	CERAMIC	textile + copper wires	SBR/NBR	6	3	yes		G7
ASPIREX	20 - 250	-15 / +60	suction equipment	PVC	PVC wire	PVC	-	-	yes		G8
<b>Beverage &amp; Food</b>											
DRINKPRESS WB/L 10	10 - 25	-20 / +100	food & beverage, wash-down	NBR	textile	NBR/PVC	10	4		FDA - EC	H4
GAMBRINUS UPE SM EN 12115	19 - 100	-20 / +100	food & beverage	UHMWPE	textile + copper wires	EPDM	16	4	yes	**EN 12115 - FDA - DM	H5
GAMBRINUS BLUE 10	19 - 102	-30 / +80	fatty food & beverage	NBR	textile	NBR/PVC	10	3		*BIR - DM - FDA - EC	H6
GAMBRINUS BLUE SM 10	19 - 102	-30 / +80	fatty food & beverage	NBR	textile	NBR/PVC	10	3	yes	*BIR - DM - FDA - EC	H7
GAMBRINUS RED SM 10	19 - 102	-40 / +120	wine and soft drinks food & beverage	EPDM	textile	EPDM	10	3	yes	*BIR - DM - FDA - EC	H8
VINITRESS	6 - 50	-20 / +60	food & beverage	PVC	textile	PVC	20	3		EC 90/128 CLASS A-B-C	H9
APERSPIR	12 - 150	-10 / +60	food & beverage	PVC	steel wire	PVC	15	3	yes	EC 90/128 CLASS A-B-C	H10
ENOREX	25 - 120	-25 / +60	wine and soft drinks food & beverage	PVC	PVC wire	PVC	10	3	yes	EC 1935:2004 CLASS A-B-C	H11
<b>Multipurpose &amp; Air</b>											
GST II Black 15	5 - 38	-40 / +100	compressed air, non aggressive liquids	EPDM	textile	EPDM	15	4			I4
GST II Red 15	6.5 - 38	-40 / +100	compressed air, non aggressive liquids	EPDM	textile	EPDM	15	4			I5
GST II Black 20	6.5 - 25	-40 / +100	compressed air, non aggressive liquids	EPDM	textile	EPDM	20	4			I6
PYTHON N/L 20	10 - 50	-40 / +120	multipurpose	EPDM	textile	EPDM	20	3			I7
PYTHON N/L 20	10 - 50	-40 / +120	multipurpose	EPDM	textile	EPDM	20	3			I8
PYTHON N/L 30	6 - 100	-40 / +120	multipurpose	EPDM	textile	EPDM	30	3			I9
JUMBO N/L	13 - 25	-40 / +120	multipurpose	EPDM	textile	EPDM	20	3			I10
MINIERA 20 MSHA	19 - 100	-30 / +80	compressed air, non aggressive liquids	SBR/NBR	textile	CR	20	3		MSHA	I11
E-Z FORM™ MP	12.7 - 75	-34 / +120	high flexible hose for multipurpose	CR	textile	CR	5	4	yes		I12
OILPRESS N/L 20	6 - 25	-35 / +100	multipurpose	NBR	textile	NBR/PVC	20	3			I13
OILPRESS N/L 30	6 - 25	-35 / +100	multipurpose	NBR	textile	NBR/PVC	30	3			I13
APERFRUIT 20	8 - 19	-15 / +60	agricultural spray	PVC	textile	PVC	20	4			I14
APERFRUIT 40	8 - 13	-15 / +60	agricultural spray	PVC	textile	PVC	40	3			I14
APERFRUIT 80	8 - 13	-15 / +60	agricultural spray	PVC	textile	PVC	80	2,5			I14

\*BFR Class2 - DM 21/03/73 - FDA title21 - EC 1935/2004

\*\*EN 12115 - FDA title 21 - DM 21/03/73 - DM 220 26/04/93

# Rubber Hose Construction



## Tube

It is the innermost rubber or plastic element of the hose. Must be resistant to the materials it is intended to convey. The characteristics of the rubber or plastic compound and the thickness of the tube depend on the service in which the hose will be used.

## Reinforcement

Can be textile, plastic or metal, alone or in combination, built into the body of the hose to withstand internal pressures, external forces or combination

## Cover

It is the outer element and can be made of rubber, plastic or textile materials. The function of the cover is to protect the hose from damage and environment.



## Long Length (LL)

### Production method:

Seamless extruded hoses without or on flexible mandrel and eventually white lead vulcanization with synthetic textile yarn reinforcement for standard production up to 100 m and internal diameter up to I.D. 35 mm.



## Mandrel Made (MM)

### Production method:

Hose produced on a rigid mandrel with a reinforcement of textile fabrics or steel braids, with or without steel wire helix, for standard production length up to 40 m and internal diameter range from I.D. 19 mm to I.D. 200 mm.

# PVC Hose Construction

Flexible hose having a rigid PVC spiral or a steel wire reinforcement spiral embedded in a PVC wall.

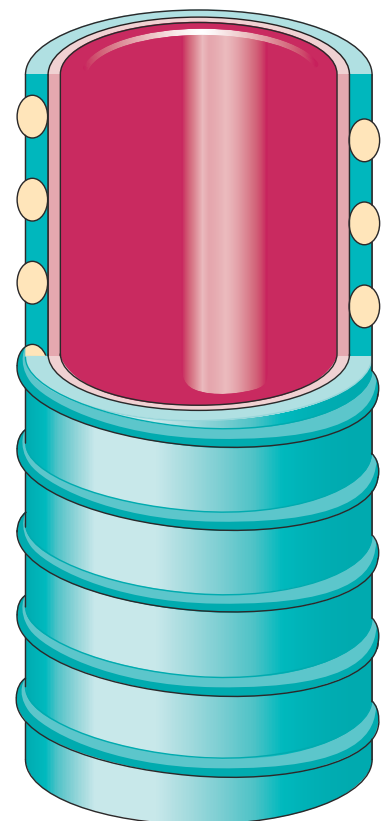
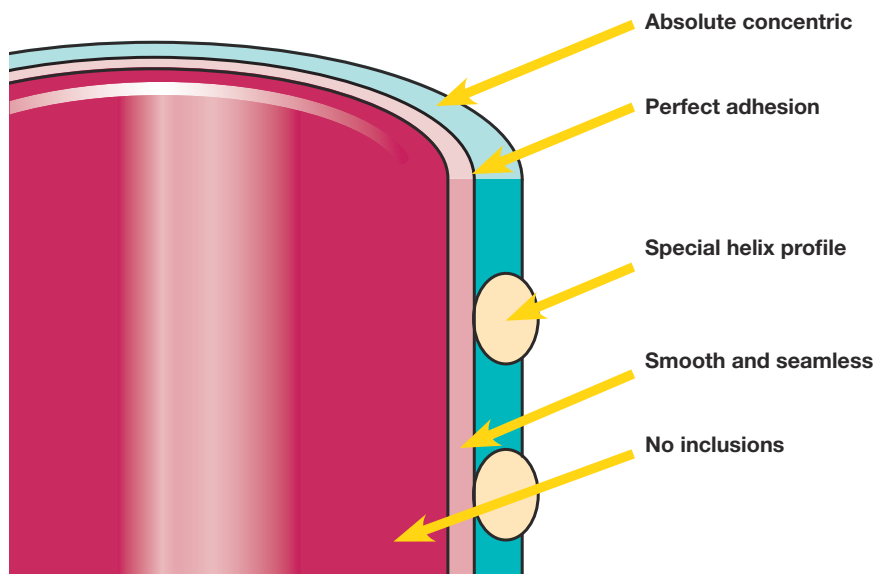



## Hose Part Number Description

IH35.... → PVC Hose



IH30.... → Long Length Rubber Hose



IH36.... → Mandrel made Rubber Hose

IH42.... → Mandrel made Rubber Hose

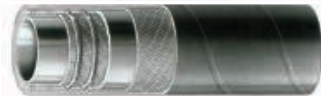

IH7.... → Global Hose Series



### Example

IH35562019/50 → PVC Hose

IH35562019/50 → PVC Hose, length 50 m

IH35562019/0 → PVC Hose, length: variable

Hose to be ordered in coils.

# Conversion Chart

	Unit	Base Unit	Conversion Unit	Factor
Length	1 inch	in	mm	25.4
	1 millimetre	mm	in	0.03934
	1 foot	ft	m	0.3048
	1 metre	m	ft	3.28084
Area	1 square-inch	sq in	cm <sup>2</sup>	6.4516
	1 square-centimetre	cm <sup>2</sup>	sq in	0.1550
	1 gallon (UK)	gal	l	4.54596
Volume	1 litre	l	gal (UK)	0.219976
	1 gallon (US)	gal	l	3.78533
	1 litre	l	gal (US)	0.264177
Weight	1 pound	lb	kg	0.453592
	1 kilogramme	kg	lb	2.204622
Torque	1 pound foot	lb • ft	kg • m	1.488164
	1 newton metre	kg • m	lb • ft	0.671969
	1 pound per square inch	psi	bar	0.06895
	1 bar	bar	psi	14.5035
	1 pound per square inch	psi	MPa	0.006895
Pressure	1 mega pascal	MPa	psi	145.035
	1 kilo pascal	kPa	bar	0.01
	1 bar	bar	kPa	100
	1 mega pascal	MPa	bar	10
	1 bar	bar	MPa	0.1
Velocity	1 foot per second	ft / s	m / s	0.3048
	1 metre per second	m / s	ft / s	3.28084
	1 gallon per minute (UK)	gal / min.	l / min.	4.54596
Flow rate	1 litre per minute	l / min.	gal / min. (UK)	0.219976
	1 gallon per minute (US)	gal / min.	l / min.	3.78533
	1 litre per minute	l / min.	gal / min. (US)	0.264178
Temperature	Fahrenheit degree	°F	°C	5/9 • (°F-32)
	Celsius degree	°C	°F	°C • (9 / 5) +32

 (UK) Unit of United Kingdom  
 (US) Unit of USA

Technical Handbook

# Before you spec it, STAMP it.

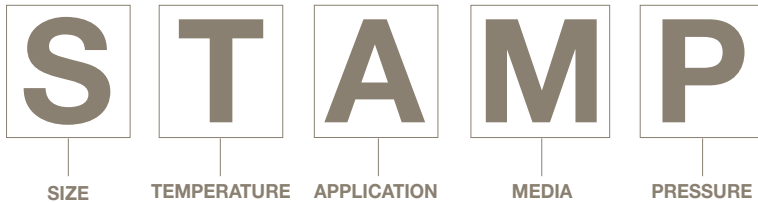

## SIZE

The hose Internal and External Diameter must be sized accurately to obtain the proper values to couple the hose with reusable or permanent fittings. The measuring system of the inside and outside diameter of the hose is universally regulated by ISO 4671 while the hose tolerances are listed in the ISO 1307 if not superseded by particular and specific other norms (i.e. EN 12115).

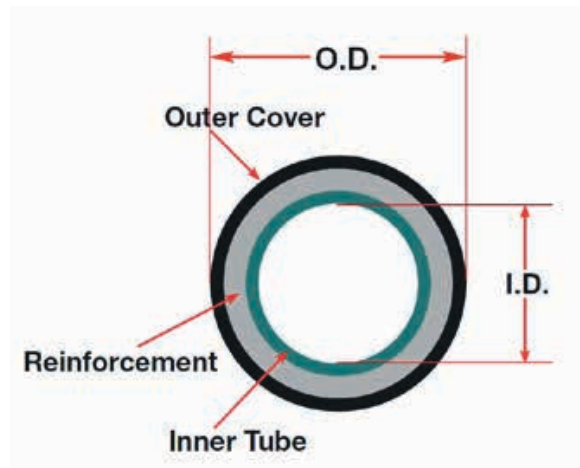

## TEMPERATURE

When specifying hose, there are two temperatures you need to identify. One is the **ambient temperature** which is the temperature that exists outside the hose in the application where it is being used; the other is the **media temperature** which is the temperature of the media conveyed through the hose. Very high or low ambient temperatures can have adverse effects on the hose cover and reinforcement materials, resulting in reduced service life. Media temperatures can have a much greater impact on hose life. For example, rubber loses flexibility if operated at high temperatures for extended periods.

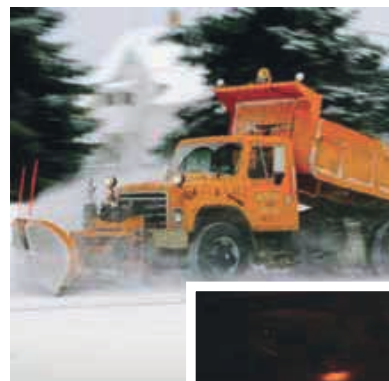



## APPLICATION

Before selecting a hose, it is important to consider how the hose will be used. Answering the following questions may help:

- Which is the media conveyed?
- What type of equipments are involved?
- Is it a static or dynamic application?
- Are there any routing constrains?
- Do you need particular cover features?
- Should the hose comply with any industry or government standards?
- Which are the electrical hose conductivity/resistance requirements?



Sometimes specific applications require hoses specific dimensions, features or performance characteristics. For example, applications where hoses will encounter rubbing or abrasive surfaces, would be best handled by our family of abrasion resistant hose. When application space is tight, bend radius is another important consideration. We offer hoses with increased flexibility and smaller outer diameters enabling faster, easier routing in small spaces, reducing both hose length and inventory requirements. Industry standards set specific requirements concerning construction type, size, tolerances, burst pressure, and media compatibility. You must select a hose that meets the legal requirements as well as the functional requirements of the application.

## MEDIA

What will the hose convey? Some applications require the use of specialized oils or chemicals. The hose you order must be compatible with the medium being conveyed. Compatibility must cover the inner tube, the cover, hose fittings, and o-rings as well. Use the Oil and Fuel and Chemical Resistance Chart you find in this section to select the correct components of the hose that will be compatible with your system's media.



## PRESSURE

Hose selection must be made so that the published maximum working pressure of the hose is equal to or greater than the maximum system pressure. Surge pressures or peak transient pressures in the system must be below the published maximum working pressure for the hose.

Each Parker hose has a pressure rating which can be found on the HOSE SELECTION MATRIX. Burst pressure ratings are not an indication that the product can be used above the published maximum working pressure. It is for this reason that the burst pressure ratings have been removed from the hose charts within the catalog. However the burst pressure is indicated by the design factor of each hose type.



## Technical Handbook

# Standards

### ABYC

WAVEMASTER™

### BfR XXI cat. 2

GAMBRINUS BLUE 10  
GAMBRINUS BLUE 10 SM  
GAMBRINUS RED 10 SM  
POLIAX PHARMA

### CARB

WAVEMASTER™

### CE

WAVEMASTER™  
SM TR 311

### DIN 73411

RADIOR DIN 6

### DIN 74310

AIRBRAKE DIN 74310

### DM 21/03/73

ENOREX  
GAMBRINUS BLUE 10  
GAMBRINUS BLUE 10 SM  
GAMBRINUS RED 10 SM  
GAMBRINUS UPE SM EN 12115  
POLIAX PHARMA

### DM 220 26/04/93

GAMBRINUS UPE SM EN 12115

### EC 1935:2004

ENOREX  
GAMBRINUS BLUE 10  
GAMBRINUS BLUE 10 SM  
GAMBRINUS RED 10 SM

### EU 10/2011

VINITRESS  
ENOREX  
APERSPIR

### EN 12115

CARBOCORD EN 12115  
CERVINO EN 12115  
CHEMIOEL EN 12115  
GAMBRINUS UPE SM EN 12115  
POLIAX D EN 12115  
POLIAX D SM EN 12115  
POLIAX F EN 12115  
POLIAX UPE CON SM EN 12115  
POLIAX UPE CON SM OND EN 12115

### EN ISO 3821

AUTOGENE EN ISO 3821 NR/L - NB/L 20  
PROPANPRESS EN ISO 3821 NA/L 20

### EN ISO 3861

LIBECCIO EN ISO 3861

### EN ISO 6134

VIGOR 2 EN ISO 6134 Type 2/A

### EN ISO 7840

SM TR 311  
WAVEMASTER™

### EPA

WAVEMASTER™

### European Pharmacopoeia

POLIAX PHARMA

### MSHA

MINIERA 20 MSHA

### FDA

DRINKPRESS WB/L 10  
GAMBRINUS BLUE 10  
GAMBRINUS BLUE 10 SM  
GAMBRINUS RED 10 SM  
GAMBRINUS UPE SM EN 12115  
POLIAX F  
POLIAX PHARMA

### NMMA

WAVEMASTER™

### SAE J 30 R7

CARBOPRESS SAE J 30 R7  
SUPER-FLEX® FL  
SUPER-FLEX® FL-7

### SAE J 20 R2 - D1

E-Z FORM™ GS

### SAE J 20 R3 Class A

SERIES 6722

### SAE J 30 R14T2

SUPER-FLEX® FL  
SUPER-FLEX® FL-7

### SAE J1527 A1-15

WAVEMASTER™

### UNI CIG 7140

CARBO G NB/R 10  
CARBO G NW/L 10

### USCG A1

WAVEMASTER™

### USP XXXII class - VI requirements

POLIAX PHARMA  
POLIAX F

# Guidelines to the Use and Cleaning of Food and Pharma Rubber Hose

The hoses offered in our catalogue are manufactured in accordance with the best production practices, observing the international norms and specifications regulating this sector to guarantee safety, performance, quality and hygiene.

Transport, storage, handling, usage and media may contaminate the hose and affect its performance.

Therefore Parker recommends cleaning and sanitizing the hose prior to and after each use to maintain hose efficiency and prevent harmful contamination.

However our suggestions are superseded by specific local government regulations and industry standards.

## Cleaning and sanitizing steps:

- flush with hot drinking water
- Cleaning process with detergents/chemicals
- Rinse with drinking water at 20 °C for max 10 min
- Sterilization process
- Rinse with drinking water at 20 °C for max 10 min
- Check to determine that all residuals have been eliminated

The frequency depends on the type of food and liquid conveyed and environment condition.

The frequency and time of exposure to detergents/disinfectants may compromise the service life of the hose. Thus we recommend regular inspection of the hose to evaluate its physical conditions.

Media	Compound	Concentration	Temperature
Hot Water	NBR, UPE, EPDM, SILICONE	-	Up to 90 °C
Steam	NBR	-	Up to 110 °C – max 10 min
	EPDM, UPE, PTFE	-	Up to 130 °C – max 30 min
	SILICONE	-	Up to 135 °C – max 18 min
Caustic Soda	NBR, SILICONE	2%	Up to 65 °C
		4%	Up to 25 °C
	EPDM, UPE, PTFE	2%	Up to 85 °C
		5%	Up to 25 °C
Nitric Acid	NBR, SILICONE	0,1%	Up to 65 °C
		2%	Up to 25 °C
	EPDM, UPE, PTFE	0,1%	Up to 85 °C
		3%	Up to 25 °C
Peracetic Acid	NBR, SILICONE	1%	Up to 25 °C
	EPDM, UPE, PTFE		Up to 40 °C

For other cleaning media and support pls contact Parker

## Technical Handbook

# Oil and Fuel Compatibility

Hose series	Max Ambient temperature °C	Fuel types							
		Fuel	Diesel	LPG-CNG	B10	B20	B100	E10	E100
ARCTIC-EDGE	100	G up to 70°	G up to 100°	⊕	G up to 70°	G up to 70°	⊕	G up to 70°	G up to 70°
CARBOCORD EN 12115	100	G up to 70°	E up to 70°	⊕	G up to 70°	G up to 70°	⊕	G up to 70°	⊕
CARBOPRESS N/L	100	G up to 70°	E up to 70°	X	E up to 70°	E up to 70°	E up to 70°	G up to 70°	⊕
Series 395 SAE J 30 R7	125	E up to 70°	E up to 100°	G up to 70°	E up to 100°	E up to 70°	G up to 70°	E up to 70°	E up to 70°
CARBURITE 10	100	E up to 70°	E up to 70°	⊕	G up to 70°	G up to 70°	⊕	G up to 70°	⊕
CERVINO EN 12115	100	E up to 70°	E up to 70°	⊕	G up to 70°	G up to 70°	⊕	G up to 70°	G up to 70°
CHEMIOEL EN 12115	100	E up to 70°	E up to 70°	⊕	G up to 70°	G up to 70°	⊕	G up to 70°	G up to 70°
E-Z FORM™ HT	150	E up to 120°	E up to 120°	⊕	E up to 120°	E up to 120°	G up to 100°	G up to 70°	G up to 70°
E-Z FORM™ MP	121	E up to 100°	E up to 100°	⊕	E up to 100°	E up to 100°	⊕	G up to 70°	G up to 70°
OILPRESS N/L	120	G up to 70°	E up to 100°	G up to 70°	E up to 100°	E up to 70°	E up to 70°	G up to 70°	E up to 70°
SM TR 311	80	E up to 70°	E up to 70°	⊕	E up to 100°	G up to 100°	⊕	E up to 100°	⊕
SUPER-FLEX® FL	125	E up to 100°	E up to 100°	⊕	E up to 100°	E up to 100°	E up to 100°	E up to 100°	G up to 100°
SUPER-FLEX® FL-7	125	E up to 100°	E up to 100°	⊕	E up to 100°	E up to 100°	G up to 100°	E up to 100°	G up to 100°
TBE	90	E up to 70°	E up to 70°	⊕	G up to 70°	G up to 70°	X	E up to 70°	G up to 70°
TBSE	100	E up to 70°	E up to 70°	G up to 70°	G up to 70°	G up to 70°	X	E up to 70°	G up to 70°
WAVEMASTER™	100	E up to 70°	E up to 70°	⊕	E up to 70°	E up to 70°	E up to 70°	E up to 70°	G up to 70°

Fuel max 50 % Aromatic ( Aliphatic /Aromatic + MBTE)  
 Diesel Std mineral Diesel  
 LPG-CNG Liquefied petroleum gas or Compressed Natural gas  
 B10 Biodiesel 10 % in std diesel  
 B20 Biodiesel 20 % in std diesel  
 B100 Biodiesel 100 %  
 E10 Ethanol Alcohol 10 % in Fuel  
 E100 Ethanol Alcohol 100 %

The indicate temperature is related to the Media and not to the ambient

**E** = Excellent  
**G** = Good  
**⊕** = Conditional  
**X** = Unsatisfactory

# Conductive Value Table

As for ISO 8031

$R < 10^3$	Conductive Compound
$10^3 < R < 10^6$	Antistatic Compound
$R > 10^6$	Insulating Compound

## Electrical Properties of Rubber Hose

### Electrical Conductivity

Industrial hoses generally fall into three categories: conductive, nonconductive, or somewhere in-between. Because of its unique properties, it is possible for rubber to be nonconductive at low voltage and conductive at high voltage. When using a hose in an application that has electrical resistance requirements (low electrical resistance for conductive applications or high electrical resistance for nonconductive applications), always select a hose that is specifically designed to meet the specific need. Since conductivity or no conductivity is not a consideration for many applications, electrical resistance ratings do not exist for many hoses.

### Conductive & Antistatic Hose

Static electricity is generated by the flow of material (even some liquids) through a hose. As the material flows, molecules collide and generate friction, which creates minute amounts of electrical charge (excess electrons). The charge accumulates potential energy at the delivery end of the hose (coupling/nozzle). The amount of charge increases with material volume and linear velocity, coarseness of the material, and length of the hose. If not properly grounded, the accumulated charge (potential energy) will seek its own ground. The charge will be attracted to external materials in proximity (such as a steel storage container); if not properly grounded, the electrons may arc (jump) to the external material, igniting volatile materials in the hose, or in proximity to the hose. Electrically conductive wires and conductive rubber components are used in hose to prevent static electricity build-up and discharge as a spark. It is essential that the user determine the need for static bonded hose based on (a) the intended use of the hose, (b) instructions from the company's safety division, (c) the insurer, and (d) the laws of the localities and states in which the hose will be used. Some types of hose include a helical or static wire(s). This wire can be used for electrical continuity provided that proper contact is made and maintained between it and the hose couplings.

### Nonconductive Hose

Nonconductive hose constructions are those that resist the flow of electrical current. In some specific applications, especially around high voltage electrical lines, it is imperative for safety that the hose be nonconductive. Unless the hose is designed particularly to be nonconductive and is so branded, do not conclude that it is nonconductive. Many black rubber compounds are inherently and inadvertently conductive. Nonconductive hose is usually made to a qualifying standard that requires it to be tested to verify the desired electrical properties. The hose is frequently (but not necessarily) non-black in colour and clearly branded to indicate it is designed for nonconductive applications.

#### WARNING!

Unless a hose is described as, or specifically and clearly branded to be conducting or nonconducting, assume that the electrical properties are uncontrolled.



## Technical Handbook

# Properties of Basic Rubber Compounds

This table provides some information on the general properties of the most common rubber compounds. Most compounds used in the manufacture of rubber hose are made of different basic rubbers, each contributing to the physical properties of the finished product.

ASTM D 1418	Chemical Name	Properties
CR	<b>Chloroprene</b>	Excellent weathering and ozone resistance, flame retarding, abrasion resistance. Good resistance to compressed air and to oil.
CSM	<b>Chloro-sulfonyl-polyethylene</b>	Excellent resistance to ozone, weathering and acid, particularly of the coloured compounds. Resistant to petroleum based fluids.
EPDM	<b>Terpolymer of ethylene-propylene-diene</b>	Good resistance to heat, ageing and abrasion. Poor resistance to petroleum based fluids.
EPM	<b>Copolymers of ethylene and propylene</b>	Excellent resistance to heat, ageing, abrasion and ozone. Good resistance to many chemicals. Poor resistance to aromatics.
FKM	<b>Fluorine rubber</b>	Excellent resistance to a wide range of chemicals and to heat. Poor physical properties.
IIR	<b>Isobutene-isoprene</b>	Good resistance to chemicals, such as alcohols, ketones and esters.
NBR	<b>Acrylonitrile-butadiene</b>	Excellent oil resistance good aromatics and solvents resistance.
NR	<b>Natural rubber</b>	Good physical properties including abrasion and low temperature resistance. Poor resistance to petroleum based fluids.
SBR	<b>Styrene-butadiene</b>	Good physical properties with resistance to heat and abrasion. Poor resistance to petroleum based fluids.
NBR/PVC	<b>Acrylonitrile-butadiene-vynil-chloride</b>	Good resistance to oil and aromatics. Recommended as hose cover, when a good weathering, ozone and abrasion resistance is required.
UHMWPE	<b>Ultra high molecular weight polyethylene</b>	Excellent abrasion resistance and very low coefficient of friction. Excellent resistance to chemicals, oil and aromatic fuels. Biologically inert and suitable for foodstuffs delivery.
PTFE	<b>Polytetrafluoroethylene</b>	Excellent resistant against the majority of chemicals, also at high concentration. Superior resistance to heat. Very low friction. Great mechanical properties.
Silicone (VMQ)	<b>Polysiloxane</b>	Outstanding Heat and cold resistance. Resistance to oils, solvents and other chemicals. Electrical insulation.

Chemical Resistance Table

# Chemical Resistance Table

The following table is essentially based upon the most updated technical data available, on information from raw material suppliers, as well as some International Standards, e.g. ISO TR 7620, EN 12115, and other publications.

Due to the big variety and amount of different chemical products, the given ratings are only partly based on our own tests. Consequently, the chart is given as a guidance only, and it cannot be assumed as a guarantee, expressed or implied, for the suitability of a product for a specific application. This is due to the widespread range of parameters which are not under our direct control like temperature (internal and external) pressure (constant or peaks) frequency of service and working environment.

For the same reasons, it is impossible to give scientifically based indications concerning service life of hoses, and to determine a generally valid replacement date. This can be verified for instance with periodical hydrostatic tests and a visual check. When in doubt please contact our technical service.

Ratings are based on room temperature.

Parker will cooperate by supplying sampling for tests, and carrying out tests with special chemical products.

## WARNING

The service life of rubber hoses is not endless. Consequently the user must periodically check the suitability of a rubber hose for the intended application, particularly in the presence of dangerous or polluting chemical products or when using the hose at elevated pressures and/or temperatures.

Continuous use at the highest allowed pressures and temperatures dramatically reduces the service life of a rubber hose.

After use hose must be emptied out and washed down.

Many chemical products can cause severe injuries to people or damage to property, or risks of environmental pollution if the hose leaks or bursts.

Trade Name	Description	ASTM Codes
Butyl	Isobutylene-Isoprene	IIR
CPE	Chlorinated Polyethylene	CM
EPDM	Ethylene-Propylene-Diene	EPDM
Hypalon	Chlorosulfonated Polyethylene	CSM
Hytrel	Thermoplastic Polyester	TPC-ET
Natural	Natural Rubber	NR
Neoprene	Polychloropren	CR
Nitrile	Acrylonitrile	NBR
Nylon	Nylon Polymer	-
SBR	Styrene-Butadiene	SBR
Teflon	Fluorocarbon Resin	PTFE
UHMW	Ultra-High Molecular Weight Polyethylene	-
Viton	Floroelastomer	FKM
XLPE	Cross-Linked Polyethylene	XPE

\* compounds not in catalogue. Ask Parker for right solution

**KEY**  
E = Excellent  
G = Good  
C = Conditional  
X = Unsatisfactory

## Technical Handbook

## Chemical Resistance Table

Chemical or Material Conveyed	Butyl	CPE	EPDM	CSM	TPC-ET	Natural	Neoprene	Nitrile	Nylon	SBR	TPV	PTFE	UHMW
1 UNDECANOL	E			E		E		E				E	
1,4-DIOXANE	G		G	X		X	X	X	E	X		E	
1-AMINO-2-PROPANOL	E			C		G		G				E	
1-AMINO BUTANE	X		C	C		X	X	C		X		E	
1-AMINOPENTANE	G		X	G		G	X	C				E	
1-BROMO-2 METHYL PROPANE	X			X		X	X	X				E	
1-BROMO-3 METHYL BUTANE	X		X	X		X	X	X				E	
1-BROMOBUTANE	X			X		X		X				E	
1-CHLORO-2-METHYL PROPANE	X			X		X		X				E	
1-CHLORO-3-METHYL BUTANE	C		X	X		X	X	X	E			E	
1-DECANOL	C			E		C	X	E				E	
1-HENDACONAL		E											
2 (2AMINOETHYLAMINO) ETHANOL	E			G		G		G					
2 (2ETHOXYETHOXY) ETHANOL	E		G	G		C	C	G	E	G		E	
2 (2ETHOXYETHOXY) ETHYL ACETATE	G		X	G		X	X	C		X		E	
2,4-DI-SEC-PENTYLPHENOL		E											
2-AMINOETHANOL	E		G	G		G	G	G				E	
2-CHLORO-1-HYDROXY-BENZENE		C											
2-CHLOROPHENOL	G	G	X	C	X	X	X	X	X	X	X	E	
2-CHLOROPROPANE	X		X	X		X	X	X	X	X		E	
2-ETHOXYETHANOL	G		G	C		C	C	G		X		E	
2-ETHOXYETHYL ACETATE	G	X	G	X	X	X	X	X	G	X		E	
2-ETHYL (BUTYRALDEHYDE)	G			X		X		X				E	
2-ETHYL-1-HEXANOL	E		E	E		E	E	E		E	E	E	
2-ETHYLHEXANOIC ACID	C			G		C		C				E	
2-ETHYLHEXYL ACETATE	E			E		X		X				E	
2-OCTANONE	G			X		X		X				E	
3-BROMOPROPENE	X			X		X	X	X				E	
3-CHLORO-2-METHYL PROPANE		G											
3-CHLOROPROPENE	C		X	X		X	X	G		E		E	
4-HYDROXY-4-METHYL-2-PENTANONE	E		E	C	C	C	C	X	G	C		E	
ACETALDEHYDE	E		E	C	G			X	X	E	X	E	G
ACETAMIDE			E				G						E
ACETIC ACID, GLACIAL	G	E	G	C	E	X	X	G	X	C	G	E	E
ACETIC ACID 10 %	E	E	E	E	X	B	B	X	E	F	B	E	E
ACETIC ACID 30 %			E				G						E
ACETIC ACID 50 %	E	E	E	E	C	X	C	C	C	X		G	E
ACETIC ANHYDRIDE	G	E	G	E	C	C	G	X	X	X	G	E	G
ACETIC OXIDE	G		B	E		X					B	E	
ACETONE	E	G	E	X	C	C	X	X	E	C	E	E	E
ACETONE CYANOHYDRIN	E			C		C	B	X			E	E	G
ACETONITRILE	E		E	G		B	E	C			E	E	
ACETOPHENONE	G		E	X		X	X	X		X	E	F	X
ACETYL ACETONE	E	G	E	X		X	X	X		X	E	E	E
ACETYL CHLORIDE	X	E	C		X		X	X	X	X	C	E	G
ACETYL OXIDE	E		G	X		C		X			G	E	E
ACETYLENE	E	G	E	C	G	G	E	E	E	C	E	E	E
ACETYLENE DICHLORIDE	C		C	X		X	X	X				E	
ACETYLENE TETRACHLORIDE	X		X	X		X	X	X				E	
ACROLEIN	E		E	G		G	C	C		C		E	X
ACRYLIC ACID		E											
ACRYLONITRILE	X	E	X	C		C			E	C		E	C
ADIPIC ACID			E			E	E	E				E	
AIR +149 °C (+300 °F)	G		G	G		X	G	G		X	E		X
ALK-TRI	X			X		X		X				E	
ALLYL ALCOHOL	E		E	E		E	E	E				E	E
ALLYL BROMIDE	X			X		X						E	G
ALLYL CHLORIDE		G		X		X		G		G		E	G
ALUM	E	E	E	E		E	E	E	G			E	E
ALUMINUM ACETATE (AQ)	G	E	E			E	G	G		X		E	E
ALUMINUM CHLORIDE (AQ) 40 %	G	C				E	E	G	X			E	
ALUMINUM FLUORIDE	E		E	E		E	E	E	G	E		E	E
ALUMINUM FORMATE	G			X		X						E	E
ALUMINUM HYDROXIDE	E		E	G		E	E	E	G	G		E	E
ALUMINUM NITRATE (AQ)	E	E	E	E		E	E	E		E		E	E
ALUMINIUM PHOSPATE			E				E						B

E = excellent; G = good; C = conditional; X = unsatisfactory

\* compounds not in catalogue. Ask Parker for right solution

Chemical Resistance Table

Chemical or Material Conveyed	Butyl	CPE	EPDM	CSM	TPC-ET	Natural	Neoprene	Nitrile	Nylon	SBR	TPV	PTFE	UHMW
ALUMINUM SULFATE (AQ)	E	E	E	E	G	E	E	E	E	G	E	E	E
ALUMS-NH3-CR-K	E		E	E		E	E	E	C	E		E	E
AMINES - MIXED	G		G	X	G	G		X		G			
AMINO XYLENE	G		C										
AMINO BENZENE		G							C				
AMINODIMETHYLBENZENE	G	C										E	
AMINOETHANE	G		E	C		C	X	X		C		E	
AMMONIA LIQUID			E				E						G
AMMONIUM ANHYDROUS			E				E						G
AMMONIUM CARBONATE (AQ)	E		E	G		E	E	G	G	E		E	E
AMMONIUM CHLORIDE (AQ)	E	G	E	G	E	E	E	G		E	E	E	E
AMMONIUM HYDROXIDE	E	E	E	E								E	E
AMMONIUM NITRATE (AQ)	E	G	E	E	G	E	E	E	G	E		E	E
AMMONIUM PHOSPHATE, DIBASIC	E	E	E	E		E	E	E	E	E		E	E
AMMONIUM SULPHATE (AQ)	E	E	E	E	G	E	E	E	G	G		E	E
AMMONIUM SULPHITE	E		E	E		E	E	E		E		E	
AMMONIUM THIOSULPHATE	E		E	E		E	E	E				E	
AMYL ACETATE	G		E	X	C	X	X	X	G	X	X	E	E
AMYL ACETONE	G			X		X						E	
AMYL ALCOHOL	E	E	E	E	E	E	E	G	E	E	E	E	E
AMYL AMINE	G			C		C		C				E	
AMYL BROMIDE												E	
AMYL CHLORIDE	X	C	X	X		X	X		E	X		E	E
AMYL ETHER				C				C				E	
ANETHOL	X	X		X		X			G			E	G
ANILINE	E	G	G	X	X	X	X	X	C	X		E	E
ANILINE DYES	G		G	G		G	C	X	X	G		E	E
ANILINE OIL	G	G	C									E	
ANIMAL FATS	C		E	C	G		G	E	E	X	E	E	E
ANTIMONY CHLORIDES	E		E	G			X	G				E	
AQUA REGIA	X		G	X		X	X	X		X		E	X
ARGON	G		E	X	E	X	X	E	E	X		E	E
AROMATIC HYDROCARBONS													C
ARSENIC ACID	E	E	E	E		G	E	E	G	E		G	E
ASPHALT	X		X	X	C	X	X	X	E	X		E	X
ASTM FUEL A	X	E	X	G	E	X	G	E	E	X	X	E	G
ASTM FUEL B	X	G	X	X	E	X	X	X	E	X	X	E	G
ASTM FUEL C	X	C	X	X	E	X	X		E	X	X	E	G
ASTM OIL NO. 2	X	E	X	X	E	X	G	E	E	X	X	E	E
ASTM OIL NO. 3	X		X	G	E	X	C	E	E	X	X	E	E
ASTM OIL NO. 4	X		X	X		X	X	G		X			E
ASTM OIL NO. 1	X	E	X	G	E	X	E	E	E	X	X	E	E
AUTOMATIC TRANSMISSION FLUID	X		X	C	E	X	G	E	G	X	X	E	E
BANANA OIL			G	C				X		X		E	E
BARIUM CHLORIDE (AQ)	E	G	E	E	G	E	E	E	G	E		E	E
BARIUM HYDROXIDE (AQ)	E	G	E	E	G	E	E	E	G	E		E	E
BARIUM SULFIDE (AQ)	E		E	E		E	E	E		G		E	E
BEER	E		E	E		E	G	E		E		E	E
BEET SUGAR LIQUORS	E	G	E	E	G	E	G	E	E	E		E	E
BENZAL CHLORIDE	G											E	E
BENZALDEHYDE	G		E	X	G	X	X	X	E	X	X	E	E
BENZENE	X	C	X	X	C	X	X	X	G	X	X	E	G
BENZENE CARBOXYLIC ACID	E			X			E	X				E	
BENZINE	X		X	X		X	C	C	G	X		E	
BENZOIC ACID	X					X	E	X	E	X		E	E
BENZOL		C	X		C			X	G			E	G
BENZOTRICHLORIDE												E	G
BENZYL ACETATE	E			G		X						E	E
BENZYL ALCOHOL	G		G	G	C	X	X	X	C	X	X	E	E
BENZYL CHLORIDE	X	X	X	X		X	X	X		X		E	E
BENZYL ETHER	G		C	X		X	X	X		X		E	
BIS (2-CLOROETHYL) ETHER	X			X		X		X		X		E	
BLACK SULFATE LIQUOR	G	C	G	G	G	G	G	G	C	G		E	E
BLEACH (2 - 15 %)	G		E	E	G	X	X	X	C	X		E	E
BORAX SOLUTION	E	G	E	E	E	G	E	G	G	G		E	E
BORIC ACID	E		E	E	E	E	E	E	G	E	E	E	E

E = excellent; G = good; C = conditional; X = unsatisfactory

\* compounds not in catalogue. Ask Parker for right solution

## Technical Handbook

## Chemical Resistance Table

Chemical or Material Conveyed	Butyl	CPE	EPDM	CSM	TPC-ET	Natural	Neoprene	Nitrile	Nylon	SBR	TPV	PTFE	UHMW
BRAKE FLUID (HD-557) 12 DAYS	G	E	E	G			G	C	E	E		E	
BRINE	E	G	E	E	G	E	G	E	G			E	E
BROMACIL			E										
BROMOBENZENE	X	X	X	X		X	X	X		X		E	C
BROMOCHLOROMETHANE	X	X	G	X		X	X	X				E	
BROMOETHANE	X		X	X		C	X	G		X		E	
BROMOTOLUENE	X	X		X		X				X		E	
BUGDIOXANE													
BUNKER OIL	X		X	X		X	X	E		X		E	E
BUTADIENE	X		X	X		X	X	X		X		E	E
BUTANE	X		X	X	E	X	C	E	E	X		E	E
BUTANOIC ACID			G	C								E	
BUTANOL (BUTYL ALCOHOL)	G	G	G	E	G	E	E	E	G	E	G	E	E
BUTANONE	E	G	E	X	E			X	G		X	G	E
BUTOXYETHANOL	E		E	X		X	X	C				E	
BUTYL ACETATE	X	C	X	X	C	X	X	X	G	X		X	E
BUTYL ACRYLATE	X		X	X		X	X	X				E	G
BUTYL ALCOHOL	G	G	G	E	G	E	E	E	G	E	G	E	E
BUTYL ALDEHYDE	G		G	C			C				G	E	E
BUTYL BENZYL PHTHALATE	E			X		X				X		E	E
BUTYL CARBITOL	E		E	X		X	C	X		X		E	E
BUTYL CELLOSOLVE	E		G	X		X	X	C		X	E	E	E
BUTYL CHLORIDE	C			X		X						E	C
BUTYL ETHER	X		X	X		X	X	X		X		E	E
BUTYL ETHER ACETALDEHYDE	G			X		X			X			E	E
BUTYL ETHYL ETHER	X			X		X		G				E	E
BUTYL OLEATE	G		G	X		X	X	X		X		E	
BUTYL PHTHALATE	G		E	X		X				X		E	
BUTYL STEARATE	X		X	X		X	X	G		X		E	E
BUTYLENE	X		X	X	G	X	C	E	G	X		E	
BUTYRALDEHYDE	G		C			X	X	X		X			E
BUTYRIC ACID	G		G	C		X	X	X		X		E	E
BUTYRIC ANHYDRIDE	C			G		C		C				E	
CADMIUM ACETATE	E			E		X						E	E
CALCIUM ACETATE	E			C		E	G	G		X		E	E
CALCIUM ALUMINATE	E			E		E		E				E	
CALCIUM BICHROMATE	E			C								E	
CALCIUM BISULFIDE			X		G		C	E	G	G		E	
CALCIUM CHLORATE			E				E						E
CALCIUM CHLORIDE	E	G	E	E	E	E	E	E	E	E		E	E
CALCIUM HYDROXIDE	E	G	E	G	E	E	E	E	E	E		E	E
CALCIUM HYPOCHLORITE	E	G	E	E	C	X	C	X	X	X		E	C
CALCIUM NITRATE	E		E	E		E	E	E	E	E		E	E
CALCIUM SULFIDE	E	X	E	E		X	E	E	E	X		E	E
CAPRILIC ACID	C			G		C		C				E	E
CARBAMIDE	G			E		E	G	G				E	
CARBITOL	E		G	G		X	C	G	E	G		E	E
CARBOLIC ACID (PHENOL)	G	G	X	X		X	X	X	X	X	X	E	E
CARBON DIOXIDE	G		G	G		G	G	E	E	G		E	E
CARBON DISULFIDE	X		X	X		X	X	X	X	X		E	E
CARBON MONOXIDE	E	G	E	E	E	C	E	E	E	G	E	E	E
CARBON TETRACHLORIDE	X	C	X	X	X	X	X	C	X	X	X	E	G
CARBON TETRAFLUORIDE			G										B
CARBONIC ACID	E	X	E	E	X	E	G	G	G	G	X	E	
CASTOR OIL	G	G	G	E	C	E	E	E	G	E	C	E	E
CAUSTIC SODA (SEE SODIUM HYDROXIDE)	E		E		C		E		G		E	E	
CELLOSOLVE ACETATE	G		G	X		X	X	X	G	X		E	E
CELLUGUARD	E		E	X		E	E	E	G	E		E	
CELLULOSE ACETATE							X						B
CETYLIC ACID	G	G	G	C	E	E	G	E	C	B	E	E	
CHINA WOOD OIL (TUNG OIL)	X	C	X	E	G	X	E	E	G	X		E	
CHLORDANE	X		X	C	C	X	C	G	G	X			
CHLORINATED SOLVENTS	X	X	X	X		X	X	X	X	X		E	
CHLORINE GAS (DRY)							C						C
CHLORINE WATER SOLUTION (MAX. 3 %) + G108													E
CHLORO-2-PROPANONE	X		E	X		X	C	X		X		E	

E = excellent; G = good; C = conditional; X = unsatisfactory

\* compounds not in catalogue. Ask Parker for right solution

Chemical Resistance Table

Chemical or Material Conveyed	Butyl	CPE	EPDM	CSM	TPC-ET	Natural	Neoprene	Nitrile	Nylon	SBR	TPV	PTFE	UHMW
CHLOROACETIC ACID	G		G	G	X	X	X	X	X	X	X	E	E
CHLOROACETONE	X		E	X		X	C	X		X		E	E
CHLOROBENZENE, MONO, DI, TRI	X		X	X	X	X	X	X	E	X	X	E	G
CHLOROBUTANE	C			X		X		X				E	G
CHLOROETHYLBENZENE	X	X	X	X		X				X		E	E
CHLOROFORM	X	X	X	X	X	X	X	X	X	X	X	E	E
CHLOROPENTANE	C			X		X				X		E	E
CHLOROPHENOL													B
CHLOROSULFONIC ACID	X	X	X	X	X	X	X	X	X	X	X	E	X
CHLOROTOLUENE	X		X	X		X	X	X		X		E	G
CHLOROX	G		G	G		X	G	G		X		E	G
CHROME PLATING SOLUTIONS	X		X	X		X	X	X		X		E	
CHROMIC ACID	G	X	X	X	X	X	X	X	X	X	X	E	
CHROMIUM TRIOXIDE	G	X	X	X	X	X	X	X	X	X	X	E	
CINNAMENE	X		X	X	X	X	X	X		X		E	
CIS-9-OCTADECENOIC ACID	X	X	C	G	E	X	C	E	E	X		E	
CITRIC ACID	E	X	E	E	G	E	E	E	G	E	E	E	E
COAL OIL	X		X	C		X	G	E	E		X	E	E
COAL TAR	X		X	X	X	X	C	G		X	X	E	E
COAL TAR NAPHTHA	X		X	X		X		X		X		E	
COCONUT OIL	G		G	C		X	C	E		X		E	E
COKE OVEN GAS	X		X	X		X	X	X	E	X		C	
COOLANOL (MONSANTO)	X		X	G	X	X	G	E		X		E	
COPPER CHLORIDE	E	X	E	G	E	G	G	E	C	E		E	E
COPPER CYANIDE	E		E	G		E	E	E	G	E		E	E
COPPER HYDRATE	E			G		C		G				E	E
COPPER HYDROXIDE	E			G		C		G		G		E	
COPPER NITRATE			E				E						E
COPPER SULFATE	E	X	E	E	E	G	E	E	G	G		E	E
CORN OIL	G		X	G	E	X	C	E	G	X	E	E	E
COTTONSEED OIL	C	G	C	G	E	X	C	G	E	X		E	E
CREOSOTE	X		X	X		X	X	G	X	X		E	E
CRESOLS	X		X	X	X	X	X	X	X	X	X	E	E
CRESYLIC ACID	X		X	X		X	X	X		X		E	E
CROTONALDEHYDE	E		E	X		X	X	X		C		E	E
CRUDE OIL			X				X	G	E	X		E	E
CUMENE	X		X	X		X	X	X		X		E	E
CUPRIC CARBONATE	E			E		C	E	E				E	E
CUPRIC HYDROXIDE	E			G		C		G				E	
CUPRIC NITRATE	E		E	E		G	E	E				E	E
CUPRIC SULFATE	E		E	E		G	E	E		E		E	E
CUTTING OIL	X		X	G		X	G	E		X		E	
CYCLOHEXANE	X		X	X	E	X	X	G	G	X	X	E	E
CYCLOHEXANOL	X		X	B		X	G	G	G	X	X	E	E
CYCLOHEXANONE	X		C	X		X	X	X	G	X	X	E	E
CYCLOPENTANE	X		X	X		X	E	G				E	E
CYCLOPENTANOL	X			X		X		G		X			E
CYCLOPENTANONE	X			X		X		X				E	
CYCLOPENTYL ALCOHOL	X			X		X		G		X			E
DDT IN DEIONIZED KEROSENE	X		X	X		X	C	E	E	X		E	
DECAHYDRONAPHTHALENE	X		X	X		X	X	X	G	X	X	E	
DECAHYDROXYNAPHTHALENE		C											
DECALIN	X		X	X		X	X	X	G	X	X	E	X
DECYL ALCOHOL	X			E		X	X	E				E	E
DECYL ALDEHYDE	C			X		X						E	E
DECYL BUTYL PHTHALATE	E			X		X		X				E	E
DECYL CARBINOL	E			E		E		E				E	
"DETERGENT, WATER SOLUTION"	E		E		G		G	E		G		E	E
DEVELOPING FLUID (PHOTO)	G		G	E	X	E	E	E		G		E	
DEXTRON	X		X	X		X	G	E		X			
DI(2ETHYLHEXYL) ADIPATE	E		G	X		X	X	X				E	
DI(2ETHYLHEXYL) PHTHALATE	G		G	X	E	X	X	X	E	X		E	
DIACETONE ALCOHOL	E		E	X	C	X	X	X		X		E	E
DIACETYLMETHANE	E	G	E	X		X	X	X		X	E	E	
DIALLYLPHTHALATE		G											
DIAMMONIUM PHOSPHATE	E	E	E	E		E	E	E		E		E	

E = excellent; G = good; C = conditional; X = unsatisfactory

\* compounds not in catalogue. Ask Parker for right solution

## Technical Handbook

## Chemical Resistance Table

Chemical or Material Conveyed	Butyl	CPE	EPDM	CSM	TPC-ET	Natural	Neoprene	Nitrile	Nylon	SBR	TPV	PTFE	UHMW
DIAMYL NAPHTHALENE	E			X		X						E	
DIAMYL PHENOL	X			X		X		X		X		E	
DIAMYLAMINE	E		E	C		G		G		X		E	
DIAMYLENE	X			X		X	X	C	G			E	
DIBENZYL ETHER	G		C	X		X	X	X		X		E	E
DIBROMOBENZENE	X			X		X						E	G
DIBROMOMETHANE	X		C	X		X	X	X			X	E	
DIBUTYL ETHER	X		X	X		X	X	X		X		E	E
DIBUTYL PHTHALATE	C		E	X	G	X	X	X	E	X		E	E
DIBUTYL SEBACATE	G		G	X	G	X	X	X		X		E	E
DIBUTYLAMINE	X		X	X		X	X	X		X		E	E
DICALCIUM PHOSPHATE	E			E		E		E				E	
DICHLORO DIFLUORO METHANE	X	C	C	E	E	X	G	C	G	E	X	E	
DICHLORO ETHYLENE	C		X	X	X		X		C		X	E	
DICHLOROACETIC ACID	C			X		G						E	E
DICHLOROBUTANE	X		C	X		X	X	G		X		E	E
DICHLOROETHANE	C	X	X	X	X	X	X	X	C	X	X	E	
DICHLOROETHYL ETHER	X			X		X		X		X		E	
DICHLOROFLUOROMETHANE													E
DICHLOROHEXANE	X			X		X						E	E
DICHLOROMETHANE	X		C	X	X	X	G	X	C	X	X	E	E
DICHLOROPENTANE	X			X		X	X	X		X		E	E
DICHLOROPROPANE	X			X		X	X	X				E	E
DICHLOROPROPENE												E	E
DICHLOROTOLUENE		X											
DIESEL OIL	X	E	X	C	G	X	C	E	E	X	X	E	E
DIETHANOLAMINE	E		E	C	X	G			G	X		E	E
DIETHYL ETHER	X		X	X	C	X	X	X	E	X	E	E	
DIETHYL KETONE	G		E	X		X	X					E	
DIETHYL OXALATE	X		X	X		X	X	X				E	
DIETHYL PHTHALATE	E			X		X						E	E
DIETHYL SEBACATE	G		G	C	E	X	X	X		X	E	E	
DIETHYL SULFATE	G		E	X		X	E	X		E		E	
DIETHYL TRIAMINE	E			C		G		G				E	
DIETHYLAMINE	G		G	C		G	G	C		G		E	E
DIETHYLBENZENE	X		X	X		X	X	X		X		E	E
DIETHYLENE GLYCOL	E		E	E	E	E	E	E		E		E	E
DIETHYLENE OXIDE	X		E									E	
DIETHYLENE TRIAMINE	E		E	C		G				X	E	E	E
DIHYDROXY DIETHYL ETHER	E		E	E		E	E	E				E	
DIHYDROXY SUCCINIC ACID	G		G	E		E	C	G				E	
DIISOBUTYL KETONE	G		E	X		X	X	X		X		E	E
DIISOBUTYLENE	X		X	X		X	C	E		X		E	E
DIISODECYL PHTHALATE	E		E	X		X				X		E	E
DIISODECYL PHTHALATE	E		E	X		X	X	X				E	E
DIISOOCTYL ADIPATE	E			X		X		X		X		E	E
DIISOOCTYL PHTHALATE	E		G	X		X						E	E
DIISOPROPANOLAMINE	E			C		G		G				E	
DIISOPROPYL ETHER	X		X	C		X	X	G		X		E	
DIISOPROPYL KETONE	E		E	X		X	X	X		X		E	
DIMETHYL PHTHALATE	G		G	X	E	X	X	X		X	G	E	E
DIMETHYL SULFATE	G			X				X				E	E
DIMETHYL SULFIDE	C					X		X				E	
DIMETHYLAMINE	G		X	X			X	X				E	E
DIMETHYLANILINE	X	C	G	X			X	X		X		E	G
DIMETHYLBENZENE	X	C	X	X	X		X	X	G	X	X	X	E
DIMETHYLBUTANE		G											
DIMETHYLCARBINOL	E		G	E		E	E	G				E	E
DIMETHYLFORMAMIDE			G									E	E
DIMETHYLKETONE	E	G	E	X	C		X	X	E	C	E	E	E
DIOCTYL ADIPATE	E		G	X		X	X	X				E	E
DIOCTYL PHTHALATE	G		G	X	E	X	X	X	E	X		E	E
DIOXALANES	X		G	X		X	X	X		X		E	E
DIOXANE	G		G	X		X	X	X	E	X		E	E
DIPENTENE	X		X	X		X	X	G		X		E	
DIPENTYLAMINE	E		E	C		G		G		X		E	

E = excellent; G = good; C = conditional; X = unsatisfactory

\* compounds not in catalogue. Ask Parker for right solution

Chemical Resistance Table

Chemical or Material Conveyed	Butyl	CPE	EPDM	CSM	TPC-ET	Natural	Neoprene	Nitrile	Nylon	SBR	TPV	PTFE	UHMW
DI-P-MENTHA-1,8-DIENE	X		X	X		X	X	G		X		E	
DIPROPYLAMINE	E			C		G		G				E	
DIPROPYLENE GLYCOL	E			E		E		E				E	
DISODIUM PHOSPHATE	E		E	E		E		E				E	E
DIVINYL BENZENE	X			X		X				X		E	E
DOWELL INHIBITOR		G											
DOWFAX 2A1 SOLVENT		E											
DOWFAX 2A1 TA		E											
DOWFAX 6A1 SOLVENT		G											
DOWFAX 6A1 TA		E											
"DOWTHERM, A AND E"	X	X	X	X	G	X	X	X	X	X		C	E
DRY CLEANING FLUIDS	X		X	X			X	C		X		E	
DUCGKIRIOEBAANE	X												
DURO AW16, 31			X					E	E			E	
DURO FR-HD			X					E	E			E	
EHTYL BUTYL ACETATE	E			G		X		X				E	E
EHTYL DICHLORIDE	C		C	X		X	X	X		X		E	
EHTYLENE DIBROMIDE	X		C	X		X	X	X		X		E	G
EPICHLOROHYDRIN			C										B
ETHANOIC ACID	G	E	E	C	C	X	G	C	C	G	C	E	
ETHANOL (GRAIN ALCOHOL)	E	G	E	E	E	E	E	E	X	E	E	E	E
ETHANOLAMINE	G		G	X		G	G	G		X		E	E
ETHERS	X	G	C	X	X	X	X	X	E	X		E	
ETHYL ACETATE	G	G	E	X	C	X	X	X	E	X	E	E	E
ETHYL ACETOACETATE	G		G	X		C	X	X		C		E	E
ETHYL ACETONE	G		G	X		X	X	X		X		E	
ETHYL ACRYLATE	G		G	X		X	X	X		X		E	E
ETHYL ALCOHOL	E	G	E	E	E	E	E	E	X	E	E	E	E
ETHYL ALDEHYDE	G		E	C		X	X	X				E	E
ETHYL ALUMINUM DICHLORIDE	X			X		X		X				E	
ETHYL BENZENE	X		X	X		X	X	X		X		E	E
ETHYL BROMIDE	X		X	X		C	X	G		X		E	
ETHYL BUTANOL	E			E		E		E				E	E
ETHYL BUTYL KETONE	G			X		X		X				E	
ETHYL CELLULOSE	G		G	G	G	G	G	G	C	G		E	E
ETHYL CHLORIDE	E	X	E	C	X	C	X	E	E	G	X	E	G
ETHYL DIISOBUTYLTHIO-CARBAMATE						E				E			E
ETHYL ETHER	X	G	X	X		X	X	X	E	X		E	E
ETHYL FORMATE	G		G	G		X	G	X		X		E	E
ETHYL IODIDE	C		C	X		X	X	X				E	G
ETHYL OXALATE	X		C	X		C	X	X		X		E	E
ETHYL PHTHALATE	E			X		X		X				E	E
ETHYL SILICATE	E		E	G		G	E	E		G		E	E
ETHYLAMINE	G		E	C		C	X	X		C		E	E
ETHYLENE													E
ETHYLENE BROMIDE			C										B
ETHYLENE CHLORIDE													G
ETHYLENE CHLOROXYDRIN	G		G	C		C	G	X				E	E
ETHYLENE DIAMINE	E		E	G		G	E	G		G		E	E
ETHYLENE DIBROMIDE													B
ETHYLENE DICHLORIDE	C	X	X	C	X	X	X	X	C	X	X	E	G
ETHYLENE G MONOETHYL E ACETATE	E		E	X		C	X	C				E	
ETHYLENE G. MONOBUTYL ETHER	E		E	C		X	C	C		X		E	
ETHYLENE G. MONOHEXYL ETHER													
ETHYLENE G. MONOMETHYL ETHER	E		G	G		X	E	C				E	
ETHYLENE GLYCOL	E	G	E	E	E	E	E	E	E	E	E	E	E
ETHYLENE OXIDE	X	X	C	X	E	X	X	X	G	X		E	
FATTY ACIDS	X		X	C	G	X	G	E	E	X	X	E	E
FERRIC BROMIDE	E			E		E		E				E	E
FERRIC CHLORIDE	E	X	E	E	G	E	E	E	C	E		E	E
FERRIC NITRATE	E		E	E		E	E	E	E	E		E	E
FERRIC SULFATE	E	X	E	E	E	E	E	E	E	E		E	E
FERROUS ACETATE	E			E		X		X				E	
FERROUS CHLORIDE	G		E	G	E	E	G	E	E			E	E
FERROUS SULFATE	E		E	E	E	E	E	E	E	E		E	E
FLOUROSILIC ACID	E		E	E		E	E	E		G	C	E	C

E = excellent; G = good; C = conditional; X = unsatisfactory

\* compounds not in catalogue. Ask Parker for right solution



## Technical Handbook

## Chemical Resistance Table

Chemical or Material Conveyed	Butyl	CPE	EPDM	CSM	TPC-ET	Natural	Neoprene	Nitrile	Nylon	SBR	TPV	PTFE	UHMW
FLUOBORIC ACID	G		E	E		E	E	E		E		E	C
FLUORINE	X		E	X	X	X	X	X	X			G	X
FORMALDEHYDE	E	G	E	G	C		G	C	E	C	E	E	E
FORMALIN	E	G	E	G	C		G	C	E	C	E	E	E
FORMIC ACID	E	X	E	E	C	C	E	C	X	E	E	E	E
FREON 113	X		X	E	E	X	E	E	X	G	X	E	
FREON 12	C	C	C	E	E	C	E	E	G	E	X	E	
FREON 22	X	C	E	E	X	C	E	X	G	E	X	E	
FREON 502	E		E			E	E	G	E	E			
FUEL A (ASTM)	X	E	X	G	E	X	G	E	E	X	X	E	G
FUEL B (ASTM)	X	G	X	X	E	X	X	X	E	X	X	E	G
FUEL C (ASTM)			X				C						G
FUEL OIL	X	E	X	C	G	X	G	E	G	X		E	E
FURALDEHYDE	E	E	G	C	G	X	C	X	C	X	E	E	
FURAN	X		X	X		X	X	X		X		E	
FURFURAL	E	E	G	C	G	X	C	X	C	X	E	E	E
FURFURAN	X		X	X		X	X	X		X		E	
FURFURYL ALCOHOL	G		G	X	G	X	X	X	G	X	E	E	E
GALLIC ACID	G		G	G	X	E	G	G	G			E	E
GALLOTANNIC ACID	G		E	E		E	E	E				E	E
GAS, 100 OCTANE	X		X	X	E	X	C	E	G	X	X	E	C
GAS, COAL			E		G		E	X	E				
GASOLINE	X	E	X	X	E	X	X	E	G	X		E	G
GLACIAL ACRYLIC ACID													
GLUCONIC ACID	C			G		X		C				E	E
GLUCOSE	E		E	E	G	E	G	E	G	E		E	E
GLYCERINE	E	E	E	E	E	E	E	E	G	E	X	E	A
GLYCEROL	E	E	E	E	E	E	E	E	G	E	X	E	
GLYCOGENIC ACID	C			G		X		C				E	
GLYCOLS	E		E	E	C	E	E	E	G	E	G	E	E
GLYCONIC ACID	C			G		X		C				E	E
GLYCYL ALCOHOL	E	E	E	E	E	E	E	E	G	E	X	E	
GREASE, PETROLEUM BASE	X	E	X	X	E	X	C	E	E	X	X	E	E
GREEN SULFATE LIQUOR	E		E	G	X	G	G	G	X	G		E	E
HALON 1211							E	E					
HELIUM	E		E	E		E	E	E	E	E		E	
HEPTALDEHYDE	X			X		X		E				E	
HEPTANAL	X			X		X		E				E	E
HEPTANE	X	E	X	G	G	X	G	E	E	X		E	E
HEPTANE CARBOXYLIC ACID	C			G		X		C				E	
HEPTANOIC ACID		E											
HEPTANONE		C											
HEXADECANOIC ACID	G	G	G	C	E	E	G	E	C	B	E	E	
HEXALDEHYDE	G		E	C		X	E	X		X		E	E
HEXANE	X		X	E	E	X	E	E	E	X	E	E	G
HEXANOL	C		G	G		E	G	E		E		E	E
HEXENE	X		X	G		X	G	G		X		E	
HEXYL ALCOHOL	C		G	G		E	G	G		E		E	E
HEXYL METHYL KETONE	G			X		X		X				E	
HEXYLAMINE	G			C		C		C				E	
HEXYLENE GLYCOL	E		C	E		E	E	E				E	
HISTOWAX		E											
HYDRAULIC OIL, PETROLEUM		E	X	G	E	X	G	E	E		X	E	E
HYDRAULIC FLUID (PHOSPHATE ESTER BASE)			E				X						X
HYDRAULIC FLUID (POLYALKYLENE GLICOL BASE)			C				G						E
HYDRAZINE	E		E	G	X	X	G	G	X	G		E	
HYDROBROMIC ACID	E	X	E	E		E	X	X	X	X		E	G
HYDROCHLORIC ACID	E	X	C	C	C	C	C	C	C	X	E	E	E
HYDROCYANIC ACID	G	X	E	E	X	G	G	G	X	G	E	E	E
HYDROFLUORIC ACID	G	X	C	E	X	C	C	C	X	C	X	E	E
HYDROFLUOSILICIC ACID	E	X	E	E	G	E	G	G	X	G		E	G
HYDROGEN CHLORIDE ANHYDROUS													
HYDROGEN DIOXIDE (10 %)	C		G	G		G	X	C				E	
HYDROGEN GAS	E	C	E	E	E	G	E	E	E	G		E	E
HYDROGEN PEROXIDE 10 %	G		G	E	X	G	X	C	G	C		E	G
HYDROGEN PEROXIDE OVER 10 %	X	X	C	G	X	X	X	X	X	X		E	E

E = excellent; G = good; C = conditional; X = unsatisfactory

\* compounds not in catalogue. Ask Parker for right solution

Chemical Resistance Table

Chemical or Material Conveyed	Butyl	CPE	EPDM	CSM	TPC-ET	Natural	Neoprene	Nitrile	Nylon	SBR	TPV	PTFE	UHMW
HYDROGEN SULFIDE (WET)	E	X	E	E	E	X	E	C	X	X		E	E
HYDROXY BENZENE	G		C	C		X	X	X				E	
HYDROXYISOBUTYRONITRILE		E											
HYDROXYTOLUENE		E											
HYVAR XL			E										
IMINODI-2-PROPANOL		E											
IMINODIETHANOL		E											
IODINE	G		G	G		X	X	G	E	G		E	G
IODINE PENTAFLUORIDE	X		X	X		X	X	X		X		E	C
ODOFORM			X			X	X	E		X			
ISOBUTANAL		G											
ISOBUTANE							X						E
ISOBUTANOL (ISOBUTYL ALCOHOL)			E				E						E
ISOBUTYL ACETATE			C										B
ISOBUTYLAMINE	E			C		C		X				E	
ISOBUTYLBROMIDE	X			X		X		X				E	
ISOBUTYLCARBINOL	E		E	E		E	E	E				E	
ISOBUTYLENE													E
ISOCYANATES					G			G	G				E
ISOOCTANE	X	E	X	G	E	X	G	E	E	X	X	E	E
ISOPROPANOL			E				E						E
ISOPROPYL ACETATE	G		G	X	C	X	X	X	G	X		E	E
ISOPROPYL ALCOHOL	E		E	E	E	E	G	E	E	E		E	E
ISOPROPYL ETHER	X		X	C		X	X	G		X		E	E
JET FUELS	X		X	X		X	X	E	C	X	X	E	E
JP-4 OIL	X		X	X	E	X	X	E	C	X	X	E	E
KEROSENE	X	G	X	X	E	X	C	E	E	X	X	E	E
KETONES	G	G	E	C	X	C	X	X	E	G	X	E	E
LACQUER SOLVENTS	X	C	X	X	C	X	X	X	E	X		E	G
LACTIC ACID – COLD	E	X	E	E	X	E	E	E	E	E		E	E
LACTIC ACID – HOT			X	C	C	X	X	X	X	X		E	E
LARD	C		G	G	G	X	G	E	E	X	E	E	G
LAVENDER OIL	X		X	X		X	X	G		X		E	G
LEAD ACETATE	E		E	C		E	G	G		X		E	E
LEAD NITRATE	E		E	C		E	E	E		E		E	
LEAD SULFATE	E		E	E	G	E	G	E	G			E	E
LIME	E		E	E	G	E	E	E	G			E	
LIME BLEACH	E		E	G		E	G	E		E		E	
LIME SULFUR, WET	E		C	G		C	E	E				E	E
LIMONENE	X		X	X		X	X	X				E	
LINOLEIC ACID	X		X	X		X	C	G		X		E	
LINSEED OIL	G	G	C	G	G	X	E	E	E	X		E	E
LIQUID PETROLEUM GAS							C						E
LIQUID SOAP			E				E						B
LUBRICATING OILS, SAE	X	G	X	X	E	X	C	E	E	X	X	E	E
LYE SOLUTIONS	E	C	E	E	C	E	E	C	G	G	C	E	
M E X	G	C	E	X	C	X	X	X	E	X	X	E	E
MAGNESIUM ACETATE	E		E	E		X	X	X		X		E	
MAGNESIUM CARBONATE			E				E						G
MAGNESIUM CHLORIDE	E	G	E	E	G	E	E	E	E	E		E	E
MAGNESIUM HYDRATE	E		E	E		E	E	G				E	E
MAGNESIUM HYDROXIDE	E	G	E	E	C	E	E	E	E	G		E	E
MAGNESIUM SULFATE	E	G	E	E	G	G	E	E	E	G		E	E
MAGNESIUM SULFITE	E		E	E		G	E	E		G		E	
MALEIC ACID	X		E	X		X	X	C		X		E	E
MALEIC ANHYDRIDE	X		X	X		X	X	X		X		E	
MALIC ACID	X		X	G		E	G	E	E	G		E	E
MANGANESE SULFATE	G		E	E		G	E	E				E	E
MAPP			G				E	E		G			
MERCURY	E	G	E	E	E	E	E	E	E	E		E	E
MERCURY VAPORS	E		E	E		C	C	E		E		E	
MESITYL OXIDE	C		G	X		X	X	X		X		E	E
METHALLYL ALCOHOL	E			E		E		E				E	
METHALLYL CHLORIDE		C											
METHANE			X				G						E
METHANE CARBOXYLIC ACID													

E = excellent; G = good; C = conditional; X = unsatisfactory

\* compounds not in catalogue. Ask Parker for right solution

## Technical Handbook

## Chemical Resistance Table

Chemical or Material Conveyed	Butyl	CPE	EPDM	CSM	TPC-ET	Natural	Neoprene	Nitrile	Nylon	SBR	TPV	PTFE	UHMW
METHANOIC ACID	E	X	E	E	C	C	E	C	X	E	E	E	
METHANOL (METHYL ALCOHOL)	E	G	E	E	E	E	E	E	G	E	E	E	E
METHANOL (WOOD ALCOHOL)	E	G	E	E	E	E	E	E	G	E	E	E	E
METHOXY ETHANOL		E											
METHOXYETHOXY ETHANOL		E											
METHYL 1-2, 4-PENTANEDIOL		E											
METHYL ACETATE	G		G	C	C	X	C	X	E	X		E	E
METHYL ACETOACETATE	G		G	X		X	X	X				E	
METHYL ACETONE	G		E	X		C	X	X				E	E
METHYL ACETYLENE PROPADIENE			G				E	E		G			
METHYL ACRYLATE			G										B
METHYL ACRYLATE STAB.			G										B
METHYL ALCOHOL	E	G	E	E	E	E	E	E	G	E	E	E	E
METHYL ALLYL ALCOHOL	E			E		E		E				E	
METHYL ALLYL CHLORIDE	F	C		X		X				X			
METHYL AMYL CARBINOL	E			E		E		E				E	
METHYL BENZENE	X	C	X	X	C	X	X	X	E	X	X	E	
METHYL BROMIDE	C		C	X	X	X	X	G	G	X	X	E	G
METHYL BUTANE	X		X	X			X	E				E	
METHYL BUTANOL	E	E	E	E	E	E	E	E	E	G	E	E	
METHYL BUTYL KETONE	E		E	X		X	X	X		X		E	E
METHYL CARBITOL	E			E		X		C				E	
METHYL CELLOSOLVE	G		G	C		X	G	C		X		E	E
METHYL CHLORIDE	X	C	X	X	X	X	X	X	C	X	X	E	E
METHYL CYANIDE	E		E	G		G	E	C				E	
METHYL ETHYL KETONE	E	G	E	X	E	X	X	X	G	X	C	E	E
METHYL HEXANOL	E			E		E		E				E	E
METHYL ISOAMYL KETONE		C											
METHYL ISOBUTYL KETONE (MIBK)			G										G
METHYL METHACRYLATE	C		X	X		X	X	X	C	X	C	E	G
METHYL NORMAL AMYL KETONE	G			X		X		X				E	
METHYL PROPYL ETHER	X		G			X	X	X				E	
METHYL SALICYLATE	G		C			X	X	X				E	
METHYL STYRENE		C											
METHYL SULFIDE	C			X		X		X				E	
METHYL TERTIARY BUTYL ETHER	G	X					X	X		X		G	G
METHYL-1-PROPANOL	E		E	E		E	E	G		E		E	
METHYL-2-BUTANOL	E	E		E		E				E			
METHYL-2-BUTANONE	G	X	C	X	X	X	X	X	E	X		E	
METHYL-2-HEXANONE	G	C		X		X				X			
METHYL-2-PENTANOL	E		E	E		G	E	G				E	
METHYL-2-PENTANONE	C	X	G	X	X	X	X	X	G	X	X	E	
METHYL-2-PROPEN-1-OL	E		E	E		G	E	G				E	
METHYL-3-PENTEN-1-ONE		C											
METHYL-4-ISOPROPYL BENZENE		C											
METHYLALLYL ACETATE	E			G		X		X				E	
METHYLAMYL ALCOHOL	E		E	E		G	E	G				E	
METHYLCYCLOHEXANE	X			X		X		X				E	
METHYLENE BROMIDE	X		X	X		X	X	X				E	G
METHYLENE CHLORIDE	X		C	X	X	X	X	X	C	X	X	E	E
METHYLETHYL KETONE	E	G	E	X	E	X	X	X	G	X	C	E	E
METHYLHEXYL KETONE	G			X		X		X				E	
METHYLISOBUTYL CARBINOL	E		E	E		G	E	G				E	
METHYLISOBUTYL KETONE	C	X	G	X	X	X	X	X	G	X	X	E	E
METHYLISOPROPYL KETONE	G	X	C	X	X	X	X	X	E	X		E	
METHYLLACTONITRILE	E			C		C	B	X			E	E	
METHYLPHENOL	X		X	C		X	X	X				E	
METHYLPPROPYL CARBINOL	E			E		E		E				E	
METHYLPPROPYL KETONE	G		G	X		X	X	X		X		E	
MIL-A-6091	E		E	E		E	E	G		E			
MIL-E-9500	E		E	E		E	E	E		E			
MIL-F-16884	X		X	C		X	C	E		X			
MIL-F-17111	X		X	X		X	G	E		X			
MIL-F-25558B	X		X	G		X	G	E		X			
MIL-F-25576C	X		X	C		X	C	E		X			
MIL-F-7024A	X		X	X		X	X	E		X			

E = excellent; G = good; C = conditional; X = unsatisfactory

\* compounds not in catalogue. Ask Parker for right solution

**Chemical Resistance Table**

Chemical or Material Conveyed	Butyl	CPE	EPDM	CSM	TPC-ET	Natural	Neoprene	Nitrile	Nylon	SBR	TPV	PTFE	UHMW
MIL-G-10924B	X		X	G		X	X	E		X			
MIL-G-25013D	X		X	G		X	G	E		X			
MIL-G-25537A	X		X	G		X	G	E		X			
MIL-G-4343B	C		C	G		C	G	G		C			
MIL-G-5572	X		X	X		X	X	E		X			
MIL-G-7711A	X		X	X		X	X	E		X			
MIL-H-13910B	G		E	G		G	G	G		E			
MIL-H-19457B	E		E	X		X	X	X		X			
MIL-H-22251	E		E	G			G	G		G			
MIL-H-27601A	X		X	C		X	G	G		X			
MIL-H-5606B	X		C	G		X	G	E		X			
MIL-H-6083C	X		X	G		C	G	E		X			
MIL-H-8446B	X		X	C		X	G	G		X			
MIL-J-5161F	X		X	X		X	X	G		X			
MIL-J-5624G (JP-3, JP-4, JP-5)	X		X	X		X	X	E		X			
MIL-L-15016	X		X	G		X	G	E		X			
MIL-L-17331D	X		X	G		X	G	E		X			
MIL-L-2104B	X		X	C		X	G	E		X			
MIL-L-21260	X		X	G		X	G	E		X			
MIL-L-23699A	X		X	C		X	C	G		X			
MIL-L-25681C	E		E	G		G	G	G		G			
MIL-L-3150A	X		X	G		X	G	E		X			
MIL-L-3545B	X		X	C		C	G	G		X			
MIL-L-4339C	X		X	X		X	X	E		X			
MIL-L-6082C	X		X	G		X	G	E		X			
MIL-L-6085A	X		X	X		X	X	G		X			
MIL-L-7870A	X		X	X		X	G	E		X			
MIL-L-9000F	X		X	C		X	G	E		X			
MIL-L-9236B	X		X	X		X	X	G		X			
MIL-O-5606								E					
MIL-O-7808	X		X	X		X	X	G		X		E	
MIL-P-27402	E		E	G			G	G		G			
MIL-S-3136B TYPE 1 FUEL	X		X	G		X	G	E		X			
MIL-S-3136B TYPE 2 FUEL	X		X	X		X	X	C		X			
MIL-S-3136B TYPE 3 FUEL	X		X	X		X	X	C		X			
MIL-S-3136B TYPE 4 OIL, LOWSWELL	X		X	E		X	E	E		X			
MIL-S-3136B TYPE 5 OIL, MEDSWELL	X		X	G		X	G	E		X			
MIL-S-3136B TYPE 6 OIL, HI SWELL	X		X	X		X	X	E		X			
MIL-S-81087	E		E	E		E	E	E		E			
MINERAL OIL	X	G	X	E	E	X	E	E	E	X	X	E	E
MINERAL SPIRITS	X		X	G		X	X	E		X		E	E
MOBILE HFA			X					E	E			E	
MOLTEN SULFUR	G		E	E		G	E	G				E	X
MONOBUTYL ETHER	X		X	X		X	C	C		X		E	
MONO-CHLOROACETIC ACID	G	X	C	X	X	C	E	X	X	X	X	E	
MONOCHLOROBENZENE	X		X	X	C	X	X	X	G	X	X	E	G
MONOCHLORODIFLUOROMETHANE	X	C	E	E	X	C	E	X		E	X	E	
MONOETHANOL AMINE	G		G	C		G	G	G		G		E	E
MONOETHYL AMINE	G		E	C		C	X	X		C		E	
MONOMETHYLAMINE	C		E	C		C	C	G				E	
MONOVINYL ACETATE			G										B
MORPHOLINE			X				X	X	X			E	
MOTOR OIL			X	G	G		G	E	G			E	E
MTBE	G	X					X	X		X		G	G
MURIATIC ACID	C	X	C	C	C	C	C	C	X	X	E	E	E
NA-K			X					X				X	
NAPHTHA	X	E	X	X	E	X	X	E	E	G	X	E	E
NAPHTHALENE	X	C	X	X	C	X	X	X	G	X	C	E	E
NAPHTHENIC ACIDS		E	X	X		X	X	G		X		E	
N-BUTANAL	G		G	C		X	C	X				E	
N-BUTYLAMINE	X		C	X		X	X	X		X		E	
N-BUTYLBENZENE				X		X		X				E	
N-BUTYLBROMIDE	X			X		X		X				E	
N-BUTYLBUTYRATE	E		E	X		X	X	X		X		E	
N-BUTYLCARBINOL	E	E	E	E	E	E	E	G	E	E	E	E	
NEOHEXANE	X			X		X		E				E	

E = excellent; G = good; C = conditional; X = unsatisfactory

\* compounds not in catalogue. Ask Parker for right solution

## Technical Handbook

## Chemical Resistance Table

Chemical or Material Conveyed	Butyl	CPE	EPDM	CSM	TPC-ET	Natural	Neoprene	Nitrile	Nylon	SBR	TPV	PTFE	UHMW
NEON GAS	E		E	E		E	E	E	E	E	E	E	
NEU-TRI	X			X		X		X				E	
NICKEL ACETATE	E		E	X		E	G	G		X		E	E
NICKEL CHLORIDE	E	X	E	E	C	E	G	E	C	E		E	E
NICKEL NITRATE	E		E	E		E	E	E				E	E
NICKEL SULFATE	E	X	E	E	C	G	E	E	C	G		E	E
NIETYLENE						E							
NITRIC ACID, 10 %	E	X	E	G	C	X	G	X	C	X	E	E	E
NITRIC ACID, 13N	X	X	X	X	X	X	X	X	X	X		E	
NITRIC ACID, 13N + 5 %	X	X	X	X	X	X	X	X	X	X		E	
NITRIC ACID, UP TO 25 %	G	X	E	G	X	X	X	X	X	X		E	E
NITRIC ACID, 25 % - 40 %	C	X	G	C	X	X	X	X	X	X		E	G
NITRIC ACID, 40 % - 60 %	X	X	X	X	X	X	X	X	X	X		E	C
NITRIC ACID, CONC (16N)	X	X	X	X	X	X	X	X	X	X	X	E	E
NITRIC ACID, RED FUMING	C	X	X	X	X	X	X	X	X	X	X	E	X
NITRILOTRIETHANOL	G		E	E	X	G	X	C		G		E	
NITROBENZENE	G	C	X	X	X	X	X	X	C	X		E	E
NITROETHANE	G		G	C		G	C	X		G	E	E	E
NITROGEN	E		E	E		E	E	E		E		E	E
NITROMETHANE	G		G	C	C	G	X	X		C		E	E
NITROPROPANE			G										E
NITROUS OXIDE GAS	E		E	E		E	G	E	C			E	E
N-NONYL ALCOHOL	E			E		E		E				E	
N-OCTANE	X		X	X		X	C	E		X		E	G
NONANOIC ACID	E			X		X		E				E	
NONANOL	E			E		E		E				E	
N-SERV (75 % XYLENE)									E	E		E	
NUTO H			X					E	E			E	
NYVAC LIGHT			E					X	E			E	
O-AMINOTOLUENE		G											
OCTANOIC ACID	C			G		C		C				E	
OCTANOL	G		E	G		G	G	G		G		E	E
OCTYL ACETATE	E			E		X		X				E	E
OCTYL ALCOHOL	G		G	G		G	G	G		G		E	E
OCTYL ALDEHYDE	C			X		X		X				E	
OCTYL AMINE	E			C		C		C				E	
OCTYL CARBINOL	E			E		E		E				E	
OCTYLENE GLYCOL	E			E		E		E				E	
OIL-PETROLEUM	X	G	X	G	E	X	G	E	G	X	C	E	E
OLEIC ACID	X	X	C	G	E	X	C	E	E	X		E	E
OLEUM (FUMING SULFURIC ACID)	X	X	X	X	X	X	X	X	X	X		E	X
OLIVE OIL	G		G	G		X	G	E	E	X		E	G
ORTHO-DICHLOROBENZENE	X		X	X	X	X	X	X	E	X	X	E	
ORTHO-DICHLOROBENZOL	X		X	X	X	X	X	X	E	X	X	E	
ORTHOXYLENE	X	C	C	X	C	X	X	X	G	X	X	E	
OXALIC ACID	E	X	E	E	X	C	G	G	G	G	E	E	E
OXYDIETHANOL		E											
OXYGEN COLD			E				E						E
OZONE	G		E	E	C	X	C	X	C	X		E	C
PAINT THINNER	X		X	X		X	X	X	G	X		E	E
PALM OIL													E
PALMITIC ACID	G	G	G	C	E	E	G	E	C	B	E	E	E
PAPERMAKERS ALUM	E			E		E	E	E				E	G
PARA METHOXYPROPENYL BENZENE	X	X		X		X			G			E	
PARA-DICHLOROBENZENE	X		X	X		X	X	X		X		E	
PARAFFIN WAX	X		X	X		X	G	E		E			E
PARALDEHYDE	E		E	X		C	C	C				E	
PARAXYLENE	X		X	X		X	X	C				E	
PCB													E
P-CYMENE	X	X	X	X		X	X	X		X		E	E
PELARGONIC ALCOHOL	E			E		E		E				E	
PENTACHLOROETHANE	X			X		X	X	X				E	
PENTADIONE		G											
PENTAMETHYLENE	X		X	X		X	E	G				E	
PENTANE	X		X	C	G	X	C	E	G	X		E	G
PENTANOL	E		E	E		E	E	E				E	

E = excellent; G = good; C = conditional; X = unsatisfactory

\* compounds not in catalogue. Ask Parker for right solution

Chemical Resistance Table

Chemical or Material Conveyed	Butyl	CPE	EPDM	CSM	TPC-ET	Natural	Neoprene	Nitrile	Nylon	SBR	TPV	PTFE	UHMW
PENTANONE	G		G	X		X	X	X				E	
PENTASOL	E		E	E		E	E	G		G		E	
PENTYL ACETATE	G		E	X	C	X	X	X	G	X	X	E	
PENTYL ALCOHOL	E	E	E	E	E	E	E	G	E	E	E	E	
PENTYL BROMIDE												E	
PENTYL CHLORIDE	X	C	X	X		X	X		E	X		E	
PENTYL ETHER				C				C				E	
PENTYLAMINE	G		X	C		C	X	C				E	
PERCHLORIC ACID-2N	G		G	G	X	X	G	X	X	X	X	E	
PERCHLOROETHYLENE	X	C	X	X	X	X	X	C	C	X	X	E	G
PERCHLOROMETHANE	X					X	X	X				E	
PETROLEUM CRUDE	X		X	G	C	X	G	E	G	X		E	E
PETROLEUM ETHER	X		X	X		X	C	E	E	X		E	
PETROLEUM OILS	X	G	X	G	E	X	G	E	G	X	C	E	E
PHENBO													E
PHENOL	G			X	X	X	X	X	X	X	X	E	E
PHENOLSULFONIC ACID	C			X		X		X				E	G
PHENYLAMINE	E		G	X		X	X	X				E	
PHENYLBROMIDE	X		X	X		X	X	X				E	
PHENYLBUTANE		C											
PHENYLCHLORIDE	X		X	X		X	X	X				E	
PHENYLETHYLENE	X		X	X	X	X	X	X		X		E	
PHENYLMETHANE	X		X	X		X	X	X				E	
PHENYLMETHANOL	G		G	G	C	X	X	X	C	X	X	E	E
PHENYLMETHYL ACETATE	E			G		X						E	E
PHOSPAHTE ESTERS	E	G	E	X	C	X	X	X	E	X	E	E	
PHOSPHORIC ACID 10 %	G	X	E	E			E	E	E	G	E	E	E
PHOSPHORIC ACID 10 % - 85 %	G	X	E	E	X	G	E	X	C	G		E	E
PHOSPHORUS TRICHLORIDE ACID	E		E	X		X	X	X		X		E	
PHTALIC ANHYDRIDE			E				E						
PICRIC ACID, H2O SOLUTION	C	X	C	E	X	C	C	C	X	G	X	C	
PINE OIL	X		X	X		X	X	G		X		E	E
PINENE	X		X	X		X	X	G		X		E	E
POLY CHLORINATED BIPHENOL												E	
POLYETHYLENE GLYCOL E-400	E	E		E		E				E			E
POLYOL ESTER					X		G		G				
POLYPROPYLENE GLYCOL	E			E		E		E				E	
POLYVINYL ACETATE EMULSION (PVA)			E				G						B
POTASSIUM ACETATE	E		E	C		E	G	G	G	X		E	E
POTASSIUM BICARBONATE			E				E						E
POTASSIUM BISULFATE	E		E	E		E	E	E	G	G		E	E
POTASSIUM BISULFITE	E		E	E		E	E	E	G	G		E	E
POTASSIUM CARBONATE	E		E	E	X	E	E	E	C	E		E	E
POTASSIUM CHLORIDE	E	G	E	E	G	E	E	E	E	E		E	E
POTASSIUM CHROMATE	G		E	C		G	E	E	G	G		E	G
POTASSIUM CYANIDE	E	G	E	E	G	E	G	E	E	E		E	E
POTASSIUM DICHROMATE	E	X	E	E		C	E	E	G	G		E	G
POTASSIUM HYDRATE	E		G	E		G	G	G	G	G		E	
POTASSIUM HYDROXIDE	G	X	E	E	C	G	G	G	G	G	G	E	G
POTASSIUM NITRATE	E		E	E	G	E	E	E	G	E		E	E
POTASSIUM PERMANGANATE 5 %	E		E	G	X	E	E	C	X	G		E	E
POTASSIUM SILICATE	E		E	E		E	E	E	G	E		E	
POTASSIUM SULFATE	E		E	E	G	E	E	E	E	G		E	E
POTASSIUM SULFIDE	E		E	E		G	E	E	E	G		E	E
POTASSIUM SULFITE	E		E	E		G	E	E	E	G		E	
PRESTONE ANTIFREEZE	E	G	E	E	G	E	C	E	G	E	E	E	
PRODUCER GAS	X		X	G		X	G	E		X		E	
PROPANEDIOL	C		E	E		E	C	E		E		E	
PROPANETRIOL	E	E	E	E	E	E	E	E	G	E	X	E	
PROPANOL	E		E	E		E	E	E		E	E	E	
PROPANOLAMINE		E											
PROPANONE	E	G	E	X	C	C	X	X	E	C	E	E	
PROPEN-1-OL	E		E	E		E	E	E				E	E
PROPENEDIAMENE		E											
PROPENENITRILE	X					G	X	X				E	
PROPENYL ALCOHOL	E		E	E		E	E	E				E	E

E = excellent; G = good; C = conditional; X = unsatisfactory

\* compounds not in catalogue. Ask Parker for right solution

## Technical Handbook

## Chemical Resistance Table

Chemical or Material Conveyed	Butyl	CPE	EPDM	CSM	TPC-ET	Natural	Neoprene	Nitrile	Nylon	SBR	TPV	PTFE	UHMW
PROPENYLANISOLE	X			X		X		X				E	
PROPIONIC ACID	E		E	G		E	C	C		X		E	
PROPIONITRILE	E		E			E	G	X			X	E	
PROPYL ACETATE	G		E	X		X	X	X		X		E	E
PROPYL ALCOHOL	E		E	E		E	E	E		E	E	E	E
PROPYL ALDEHYDE	G			X		C		X				E	E
PROPYL BENZENE		C											
PROPYL CHLORIDE	C			X		X		X				E	E
PROPYL ETHER		E											
PROPYL NITRATE	G		G	X		X	X	X		X		E	
PROPYLENE	X		X	X		X	X	X		X		E	
PROPYLENE DIAMINE	E			C		G		G				E	
PROPYLENE DICHLORIDE													C
PROPYLENE GLYCOL	C		E	E		E	C	E		E		E	E
PYDRAUL, 'E' SERIES	G		G	X	G	X	X	X	G	X		E	E
PYDRAULIC 'C'	X		X	X	C	X	X	X	E	X	E	E	
PYRIDINE			G										C
PYROLIGNEOUS ACID			G										G
RESIN OIL							X						B
QUINTOLUBRIC 822 SERIES	X		X			X	X	G					
RED OIL	X	X	C	G	E	X	C	E	E	X		E	
REFRIGERANT 11	X		X	E	E	X	X	G		X		E	
REFRIGERANT 12	C	C	C	E	E	C	E	E	G	E	X	E	
REFRIGERANT 22	X	C	E	E	X	C	E	X	G	E	X	E	
RESORCINOL			G		X		X		X	G	X	E	
SAE NO. 10 OIL	X	G	X	X	E	X	C	E	E	X	X	E	
SAL AMMONIAC	E	G	E	E	E	E	E	E	C	E		E	
SEA WATER	E		E	E	E	E	G	E	E	E	E	E	E
SEWAGE	G		E	E	G	G	G	E	E	G	G	E	E
SILICATE ESTERS	C		X	G	C	X	E	G	G	X		E	
SILICATE OF SODA	E		E	E		E	E	E				E	
SILICONE GREASE	E		E	E	E	E	E	E	E	E		E	
SILICONE OIL	E		E	E	G	C	E	E	E	E		E	E
SILVER NITRATE	E		E	E		E	E	G	E	E		E	E
SKYDROL 500 TYPE 2	G	G	E	X	G	X	X	X	G	X	E	E	
SKYDROL 500B	G	G	E	X	E		X		E		E	E	
SKYDROL 500C	G	G		X	E		X					E	
SKYDROL 7000 TYPE 2	E	G	E	X	X	X	X	X	E	X		E	
SOAP SOLUTIONS	G	G	E	E	E	G	G	E	E	G	E	E	E
SODA ASH	E	G	E	E	G	E	E	E	G	E		E	E
SODA LIME	E		E	G		E	G	G				E	E
SODA NITER	E	G	E	E	G	G	G	G	E	G		E	
SODA, CAUSTIC	E	C	E	E	C	G	E	C	G	E	C	E	E
SODIUM ACETATE	E		E	C		E	G	G	G	X		E	E
SODIUM ALUMINATE	E		E	E		G	E	E	G	G		E	E
SODIUM BICARBONATE	E		E	E	G	E	E	E	E	E		E	E
SODIUM BISULFATE	E	X	E	E	C	E	E	G	C	G		E	E
SODIUM BISULFITE	E		E	E	G	E	E	E	E	G		E	E
SODIUM BORATE	E		E	E	G	E	E	E	E	E		E	E
SODIUM CARBONATE 10 % - 15 %	G	G	E	E	G	E	E	E	G	E		E	E
SODIUM CHLORATE			E										
SODIUM CHLORIDE	G	G	E	E	E	E	E	E	G	E	C	E	E
SODIUM CYANIDE	E	G	E	E	G	E	E	E	E	E		E	E
SODIUM DICHROMATE	E		C	G		X	C	E	G	G		E	E
SODIUM FLUORIDE			E				E						C
SODIUM HYDRATE	E		E	G		E	G	G	G	G		E	
SODIUM HYDROCHLORITE	G		G	E		C	C	C	G	G		E	
SODIUM HYDROXIDE (CAUSTIC SODA)	E	C	E	E	C	E	G	C	G	G	C	E	E
SODIUM HYPOCHLORITE	G	X	G	G	C	X	C	X	X	C	C	E	E
SODIUM METAPHOSPHATE	G		E	G		E	G	E	E	E		E	E
SODIUM NITRATE	E	G	E	E	G	G	G	G	E	G		E	E
SODIUM PERBORATE	E	X	E	G	G	G	G	G	E	G		E	E
SODIUM PEROXIDE	E	X	E	G	G	G	G	G	X	G		E	E
SODIUM PHOSPHATE	E		E	E	G	E	C	E	C	E		E	E
SODIUM SILICATE	E	G	E	E	G	E	E	E	E	E		E	E
SODIUM SULFATE	E	G	E	E	G	G	E	E	E	G		E	E

E = excellent; G = good; C = conditional; X = unsatisfactory

\* compounds not in catalogue. Ask Parker for right solution

Chemical Resistance Table

Chemical or Material Conveyed	Butyl	CPE	EPDM	CSM	TPC-ET	Natural	Neoprene	Nitrile	Nylon	SBR	TPV	PTFE	UHMW
SODIUM SULFIDE	E	G	E	E	G	G	E	E	E	G		E	
SODIUM SULFITE	E		E	E		G	E	E	E	G		E	E
SODIUM THIOSULFATE	E		E	E		E	E	E	G	G		E	E
SOYBEAN OIL	C	G	X	E	G	X	E	E	E	X		E	E
STANNIC CHLORIDE	G	X	E	C	G	G	C	E	C	E		E	E
STANNIC SULFIDE	E			E		E		E				E	
STANNOUS CHLORIDE	G		C	E	G	E	E	E	C	E		E	E
STANNOUS SULFIDE	E			E		E		E				E	
STEARIC ACID	G	G	G	C	G	C	G	E	E	G	E	E	E
STODDARD SOLVENT	X	G	X	X	E	X	C	E	E	X	X	E	E
STYRENE MONOMER	X		X	X	X	X	X	X		X		E	G
SULFAMIC ACID	E		X	E		G	G	C				E	
SULFUR	F		F	F		X	X	X		X		E	E
SULFUR CHLORIDE	X	G	X	C	C	X	C	C	C	X		E	E
SULFUR DIOXIDE	G		E	C	X	C	X	X	X	C		E	G
SULFUR TRIOXIDE, DRY	G		G	C	X	C	X	X	X	X		E	X
SULFURIC ACID 60 % +93 °C (+200 °F)	X	X	X		X		X	X	X	X			X
SULFURIC ACID, 25 %	G	X	E	E	E	G	E	E	X	G	E	E	E
SULFURIC ACID, 25 % - 50 %	G	X	E	G	G	G	E	E	X	G		E	E
SULFURIC ACID, 50 % - 96 %	X	X	G	C	X	X	C	C	X	X		E	E
SULFURIC ACID, CONC. 96 % - 98 %	X	X	X	X	X	X	X	X	X	X		E	E
SULFURIC ACID, FUMING	X	X	X	X	X	X	X	X	X	X		E	X
SULFUROUS ACID, 10 %	E	X	E	E	C	G	G	C	C	G		E	E
SULFUROUS ACID, 10 % - 85 %	E	X	G	E	C	G	C	C	X	C		E	E
SUTAN												E	
TALL OIL	X		X	C		X	C	E		X		E	E
TALLOW	G		E	C		C	G	E		X		E	E
TANNIC ACID	E	X	E	E	G	E	E	E	G	G	E	E	E
TAR, BITUMINOUS	X	G	X	C	G	C	C	G	G	X		E	
TAR, CAMPHOR	X	C	X	X	C	X	X	X	G	X	C	E	X
TARTARIC ACID	G	X	C	E	G	E	E	E	E	G	E	E	E
T-BUTYL AMINE			G	X									
TELONE 2													
TERPINOL	C	E	C	X		X	X	G		X		E	G
TERTIARY BUTYL ALCOHOL	G		G	G		G	G	G		G		E	E
TERTIARY BUTYL AMINE			G	X									
TERTIARY BUTYL MERCAPTAN	X		X	X		X	X	X		X		E	
TETRACHLORO BENZENE	X			X		X		X				E	
TETRACHLOROETHANE	X		X	X		X	X	X		X	C	E	C
TETRACHLOROETHYLENE	X		X	X		X	X	C	C	X		E	G
TETRACHLOROMETHANE	X		X	X		X	X	X				E	
TETRACHLORONAPHTHALENE	X			X		X		X				E	
TETRAETHYLENE GLYCOL	E			E		E		E				E	
TETRAETHYLORTHOSILICATE	E					X	X	X				E	
TETRAHYDROFURAN	G		X	X	C	X	X	X	G	X	X	E	G
THF	G		X	X	C	X	X	X	G	X	X	E	G
TIN CHLORIDES	G		E	E		E	C	E				E	E
TITANIUM TETRACHLORIDE	X		X	X		X	X	C		X		E	G
TOLUENE	X	C	X	X	C	X	X	X	E	X	X	E	E
TOLUENE DIISOCYANATE (TDI)			E										B
TOLUIDINE	X			X		X		X				E	
TOLUOL	X	C	X	X	C	X	X	X	E	X	X	E	
TRANSFORMER OIL	X		X	C		X	G	E		X		E	E
TRANSMISSION 'A' OIL	X		X	G	G	X	G	E	G	X		E	
TRI (2-HYDROXYETHYL) AMINE	G		E	E	X	G	X	C		G		E	
TRIBUTYL AMINE	E			C		G		G				E	
TRIBUTYL PHOSPHATE	G		E	X	C	C	X	X	G	X		E	E
TRICHLOROACETIC ACID	G		G	C	X	C	X	C	X	X		E	E
TRICHLORO BENZENE	X			X		X	X	X		X		E	
TRICHLOROETHANE	X		X	X		X	X	X	X	X		E	
TRICHLOROETHYLENE	X	C	X	X	X	X	X	X	C	X	X	E	G
TRICHLOROMETHANE	X	X	X	X	X	X	X	X	C	X	X	E	
TRICHLOROTOLUENE								X				E	
TRICRESYL PHOSPHATE	E		E	X	C	C	C	X	G	X		E	E
TRITHANOLAMINE	G		E	E	X	G	X	C		G		E	E
TRIETHYLAMINE	C		E			G	G	E		X		E	

E = excellent; G = good; C = conditional; X = unsatisfactory

\* compounds not in catalogue. Ask Parker for right solution



## Technical Handbook

## Chemical Resistance Table

Chemical or Material Conveyed	Butyl	CPE	EPDM	CSM	TPC-ET	Natural	Neoprene	Nitrile	Nylon	SBR	TPV	PTFE	UHMW
TRIETHYLENE GLYCOL	E			E		E		E				E	
TRIHIDROXYBENZOIC ACID	G		G	G	X	E	G	G	G	G		E	
TRIMETHYL PENTANES (MIXED)	X	E	X	C	E	X	C	E	E	X	X	E	
TRIMETHYL PENTENE		E											
TRIMETHYLAMINE		E										E	E
TRINITROTOLUENE (TNT)							G						
TRISODIUM PHOSPHATE	E		E	E	E	E	E	E	E	E		E	
TRITOYL PHOSPHATE	E		E	X	C	X	X	X	G	X		E	
TUNG OIL	X	C	X	E	G	X	E	E	G	X		E	E
TUNG OIL (CHINA OIL)	C	C	X	E	G	X	E	E	G	X		E	E
TURBINE OIL			X				C						B
TURPENTINEX	X	G	X	X		X	X	X	E	X	X	E	G
UDMH	E		E	E		E	G	G		X		E	
UNDECYL ALCOHOL	E			E		E		E				E	
UREA	E		E	E	G	E	G	G	E			E	E
URETHANE FORMULATIONS								E				E	
URIC ACID					X				G		E	E	
VARNISH	X	C	X	X		X	X	G	E	X		E	
VEGETABLE OILS	C		C	G		X	C	E	G	X		E	E
VERSILUBE F44	E		E	E		E	E	E	E	E		E	
VERSILUBE F55	E		X	E		E	E	E	E	E		E	
VINEGAR	E		E	E	C	G	G	G	E	G		E	X
VINEGAR ACID		G											
VINYL ACETATE	E		G	C		X	X	X		X		X	E
VINYL BENZENE	X		X	X	X	X	X	X		X		E	E
VINYL CHLORIDE (GAS)	X		G			G						E	E
VINYL CYANIDE	X	E	X	C		C	C	X	E	C	X	E	
VINYL ETHER	X			G		X		G				E	E
VINYL STYRENE	X			X		X				X		E	E
VINYL TOLUENE	X			X		X		X				E	E
VINYL TRICHLORIDE	X			X		X	X	X				E	E
VITAL, 4300, 5310			X					X	E			E	
VM&P NAPHTHA	X		X	X		X	C	C				E	
WATER	E	G	E	E	E	E	G	E	E	G	E	E	E
WATER, BOILING	E		E	E	C		G	G	X	G	G	G	X
WATER, SODA					E				E		E	E	
WEMCO C	X		X	X		X	G	E		X			
WHISKEY	E		E	E	G	E	E	E	E	E		E	X
WHITE OIL	X		X	X		X	G	E		X		E	E
WHITE PINE OIL	X		X	X		X	X	G		X			
WINES	E		E	E	G	E	E	E	E	E		E	X
WOOD ALCOHOL	E		E	E		E	E	E		E		E	E
WOOD OIL	C		X	C	G	X	G	E	G	X		E	E
XENON	E		E	E		E	E	E		E		E	
XYLENE, XYLLOL	X	C	X	X	C	X	X	X	G	X	X	E	C
XYLIDINE	G		C	X		X	X	C		X		E	G
ZEOLITES	E		E	E		E	E	E		E			
ZINC ACETATE	E		E	C		E	G	G		X		E	
ZINC CARBONATE	E		E	E		E	E	E				E	E
ZINC CHLORIDE	E	X	E	E	E	E	E	E	E	E		E	E
ZINC CHROMATE	E			C								E	
ZINC SULFATE	E	X	E	E	C	E	E	E	X	G		E	E

E = excellent; G = good; C = conditional; X = unsatisfactory

\* compounds not in catalogue. Ask Parker for right solution

# Chemical Resistance Guide for Silicone Hose

Chemical	*	Chemical	*	Chemical	*
Acetic acid, dilute, 10%	B	Isobutyl alcohol	A	Nitrobenzene	C
Acetic acid glacial	C	Isopropyl alcohol	A	Oleic acid	X
Acetic acid anhydride	I	Isooctane	X	Oleum	I
Acetone	X	Kerosene	X	Oxalic acid	B
Acetylene	C	Lacquers	X	Oxygen	X
Air 68 °F (20 °C)	A	Lacquers solvents	X	Palmitic acid	X
Air 150 °F (65 °C)	A	Lactic acid	A	Perchloroethylene	C
Aluminum chloride 150 °F (65 °C)	A	Linseed oil	A	Petroleum oils and crude 200 °F (95 °C)	X
Aluminum fluoride 150 °F (65 °C)	B	Lubricating oil, crude	C	Phosphoric acid, crude	C
Aluminum sulfate 150 °F (65 °C)	A	Lubricating oil, refined	C	Phosphoric acid, pure 45%	C
Alums 150 °F (65 °C)	A	Magnesium chloride 150 °F (65 °C)	A	Picric acid, molten	X
Ammonia gas, anhydrous	I	Magnesium hydroxide 150 °F (65 °C)	B	Picric acid, water solution	I
Ammonia 10%water solution	A	Magnesium sulfate 150 °F (65 °C)	A	Potassium chlorite	A
Ammonia 30%water solution	C	Mercuric chloride	A	Potassium cyanide	A
Ammonium chloride	C	Mercury	A	Potassium hydroxide	C
Ammonium hydroxide	C	Methyl alcohol, methanol	A	Potassium sulfate	A
Ammonium nitrate	A	Methyl chloride	X	Propane	X
Ammonium phosphate monobasic	A	Calcium chloride	A	Sewage	B
Ammonium phosphate dibasic	A	Calcium hydroxide	A	Soap solution	A
Ammonium phosphate tribasic	A	Calcium hypochlorite	C	Soda ash, sodium carbonate	A
Ammonium sulfate	A	Caliche liquors	B	Sodium bicarbonate, baking soda	A
Amyl acetate	X	Cane sugar liquors	A	Sodium bisulfate	A
Amyl alcohol	X	Carbolic acid, phenol	X	Sodium chloride	A
Aniline, Aniline oil	X	Carbon dioxide, dry-wet	A	Sodium cyanide	A
Aniline, dyes	X	Carbon disulfide	X	Sodium hydroxide to 50% at 140 °F	A
Asphalt	I	Carbon monoxide 140 °F (60 °C)	A	Sodium hypochlorite	B
Barium chloride 150 °F (65 °C)	A	Carbon tetrachloride	X	Sodium metaphosphate	A
Barium hydroxide 150 °F (65 °C)	A	Castor oil	A	Sodium nitrate	X
Barium sulfide 150 °F (65 °C)	A	Cellosolve acetate	X	Sodium perborate	B
Beer	A	CFC-12	I	Sodium peroxide	C
Beet sugar liquors	A	China wood oil, tung oil	X	Sodium phosphate, monobasic	X
Benzene, Benzol	X	Chlorine, dry/wet	X	Sodium phosphate, dibasic	X
Benzine, petroleum ether	X	Chlorinated solvents	X	Sodium phosphate, tribasic	X
Benzine, petroleum naphtha	X	Chloroacetic acid	I	Sodium silicate	A
Black sulfate liquor	A	Chlorosulfonic acid	X	Sodium sulfate	A
Blast furnace gas	A	Chromic acid	C	Sodium sulfide	A
Borax	B	Citric acid	A	Sodium thiosulfate, hypo	I
Boric acid	A	Coke oven gas	B	Soybean oil	A
Bromine	X	Copper chloride 150 °F (65 °C)	A	Stannic chloride	B
Butane	X	Copper sulfate 150 °F (65 °C)	A	Steam 450 °F (230 °C)	I
Butyl acetate	X	Corn oil	A	Stearic acid	A
Butyl alcohol, Butanol	C	Cottonseed oil	A	Sulfur	B
Calcium bisulfate	C	Creosote, coal tar	C	Sulfur chloride	C
Formaldehyde	B	Creosote, coal tar wood	X	Sulfur dioxide, dry	B
Formic acid	C	Creosols, cresylic acid	I	Sulfur trioxide, dry	B
Fuel oil	X	Dichlorobenzene	X	Sulfuric acid, 10%	X
Furfural	X	Dichloroethylene	X	Sulfuric acid, 11% - 75%	X
Gasoline, unleaded	X	Diesel fuel	X	Sulfuric acid, 76% - 95%	X
Gasoline + MTBE	X	Diethanolamine 20%	X	Sulfuric acid, fuming	X
Gasoline Hi Test + MTBE	X	Diethylamine	B	Sulfurous acid	X
Gelatin	A	Diisopropylamine	I	Tannic acid	B
Glucose	A	Diethylphthalate	X	Tar	B
Glue	A	Ethers	X	Tartaric acid	A
Glycerine, glycerol	A	Ethyl acetate	B	Toluene, Toluol	X
Green sulfate liquor	A	Ethyl alcohol	A	Trichloroethylene	X
HFC-134	I	Ethyl cellulose	C	Turpentine	X
Hydraulic fluids: Petroleum	C	Ethyl chloride	C	Urea, water solution	A
Hydraulic fluids: Phosphate ester alkyl	X	Ethyl glycol	A	Vinegar	A
Hydraulic fluids: Phosphate ester aryl	X	Ferric chloride 150 °F (65 °C)	A	Vinyl acetate	X
Hydraulic fluids: Phosphate ester blends	X	Ferric sulfate 150 °F (65 °C)	B	Water, acid mine	A
Hydraulic fluids: Silicate ester	X	Methyl ethyl ketone	X	Water, fresh	A
Hydraulic fluids: Water glycol	A	Methyl isopropyl ketone	C	Water, distilled	A
Hydrobromic acid	X	Milk	A	Whiskey and wines	A
Hydrochloric acid	X	MTBE	I	Xylene, xylol	X
Hydrocyanic acid	B	Mineral oils	A	Zinc chloride	A
Hydrofluoric acid	X	Natural gas	C	Zinc sulfate	A
Hydrofluosilicic acid	I	Nickel chloride 150 °F (65 °C)	A		
Hydrogen gas 140 °F (60 °C)	C	Nickel sulfate 150 °F (65 °C)	A		
Hydrogen peroxide	A	Nitric acid, crude	X		
Hydrogen sulfide, dry	X	Nitric acid, diluted 10%	C		
Hydrogen sulfide, wet	X	Nitric acid, concentrated 70%	X		

\* Resistance

A = Good Resistance

B = Fair Resistance

C = Poor Resistance

## Technical Handbook

# Rubber Hose Dimensional Tolerances

According to norms

EN ISO 7840	
On inside diameter	
I.D. 5 mm	± 0.50 mm
I.D. 8 – 19 mm	± 0.75 mm
I.D. 25 mm	± 1.25 mm
I.D. 38 – 50 mm	± 1.50 mm
Length tolerance	± 1%

EN 12115	
On inside diameter	
I.D. 19 – 38 mm	± 0.50 mm
I.D. 50 mm	± 0.70 mm
I.D. 63.5 – 100 mm	± 0.80 mm
On outside diameter	
O.D. 31 – 51 mm	± 1.00 mm
O.D. 66 – 91 mm	± 1.20 mm
O.D. 116 mm	± 1.60 mm
Length tolerance	± 1%

EN ISO 3821	
On inside diameter	
I.D. 6.3 mm	± 0.40 mm
I.D. 8 – 10 mm	± 0.50 mm
Length tolerance	± 1%

EN ISO 6134	
On inside diameter	
≤ I.D. 38 mm	± 0.50 mm
> I.D. 38 mm	± 0.70 mm
On outside diameter	
≤ O.D. 48 mm	± 1.00 mm
O.D. 54 mm	± 1.20 mm
O.D. 69 mm	± 1.40 mm
Length tolerance	± 1%

SAE J 30 R7	
On inside diameter	
I.D. ≤ 9.5 mm	± 0.40 mm
I.D. > 9.5 mm	± 0.60 mm
On outside diameter	
O.D. ≤ 15.9 mm	± 0.60 mm
O.D. > 15.9 mm	± 0.80 mm
Length tolerance	± 1%

UNI 7140	
On inside diameter	± 0.50 mm
Length tolerance	± 1%

UNI EN ISO 1307	
On inside diameter	
I.D. ≤ 5 mm	± 0.60 mm
I.D. 6 – 20 mm	± 0.80 mm
I.D. > 20 – 25 mm	± 1.20 mm
I.D. > 25 mm	± 1.60 mm
Length tolerance	± 1%

RMA steel mandrel	
On inside diameter	
I.D. ≤ 38 mm	± 0.79 mm
I.D. 40 – 120 mm	± 1.59 mm
I.D. > 120 mm	± 2.00 mm
On outside diameter	
O.D. ≤ 125 mm	± 1.59 mm
O.D. > 125 mm	± 2.00 mm
<i>Tolerances on outside diameter are valid for hoses without a built-in helix only.</i>	
Length tolerance	± 1%

# PVC Hose Dimensional Tolerances

ASPIREX	
On inside diameter	± 4%
On wall thickness	± 0.50 mm
Length tolerance	± 1%

MULTIREX, ENOREX	
On inside diameter	
I.D. ≤ 50 mm	± 0.50 mm
I.D. > 50 mm	± 1.00 mm
On wall thickness	± 0.50 mm
Length tolerance	± 1%

APERSPIR	
On inside diameter	± 1%
On wall thickness	± 0.50 mm
Length tolerance	± 1%

APERFRUT	
On inside diameter	
I.D. ≤ 16 mm	± 0.50 mm
I.D. > 16 mm	± 1.00 mm
Length tolerance	± 2%

VINITRESS	
On inside diameter	
I.D. ≤ 15 mm	± 0.50 mm
I.D. 16 – 19 mm	± 0.80 mm
I.D. > 19 mm	± 1.00 mm
On wall thickness	± 0.50 mm
Length tolerance	± 1%

All other technical data are subject to a ± 5% tolerance

## Parker Safety Guide

### Parker safety guide for selecting and using hose, tubing, fittings and related accessories

Parker Publication No. 4400-B.1 / Revised: September, 2015



## WARNING

Failure or improper selection or improper use of hose, tubing, fittings, assemblies, valves, connectors, conductors or related accessories ("Products") can cause death, personal injury and property damage. Possible consequences of failure or improper selection or improper use of these Products include but are not limited to:

- Fittings thrown off at high speed.
- High velocity fluid discharge.
- Explosion or burning of the conveyed fluid.
- Electrocutation from high voltage electric powerlines.
- Contact with suddenly moving or falling objects that are controlled by the conveyed fluid.
- Injections by high-pressure fluid discharge.
- Dangerously whipping Hose.
- Tube or pipe burst.
- Weld joint fracture.
- Contact with conveyed fluids that may be hot, cold, toxic or otherwise injurious.
- Sparking or explosion caused by static electricity buildup or other sources of electricity.
- Sparking or explosion while spraying paint or flammable liquids.
- Injuries resulting from inhalation, ingestion or exposure to fluids.

Before selecting or using any of these Products, it is important that you read and follow the instructions below. No product from any division in Fluid Connector Group is approved for in-flight aerospace applications. For hoses and fittings used in in-flight aerospace applications, please contact Parker Aerospace Group

### 1.0 GENERAL INSTRUCTIONS

Scope: This safety guide provides instructions for selecting and using (including assembling, installing, and maintaining) these Products. For convenience, all rubber and/or thermoplastic products commonly called "hose" or "tubing" are called "Hose" in this safety guide. Metallic tube or pipe are called "tube". All assemblies made with Hose are called "Hose Assemblies". All assemblies made with Tube are called "Tube Assemblies". All products commonly called "fittings", "couplings" or "adapters" are called "Fittings". Valves are fluid system components that control the passage of fluid. Related accessories are ancillary devices that enhance or monitor performance including crimping, flaring, flanging, presetting, bending, cutting, deburring, swaging machines, sensors, tags, lockout handles, spring guards and associated tooling. This safety guide is a supplement to and is to be used with the specific Parker publications for the specific Hose, Fittings and Related Accessories that are being considered for use. Parker publications are available at [www.parker.com](http://www.parker.com). SAE J1273 ([www.sae.org](http://www.sae.org)) and ISO 17165-2 ([www.ansi.org](http://www.ansi.org)) also provide recommended practices for hydraulic Hose Assemblies, and should be followed.

1.1 Fail-Safe: Hose, Hose Assemblies, Tube, Tube Assemblies and Fittings can and do fail without warning for many reasons. Design all systems and equipment in a fail-safe mode, so that failure of the Hose, Hose Assembly, Tube, Tube Assembly or Fitting will not endanger persons or property.

1.2 Distribution: Provide a copy of this safety guide to each person responsible for selecting or using Hose, Tube and Fitting products. Do not select or use Parker Hose, Tube or Fittings without thoroughly reading and understanding this safety guide as well as the specific Parker publications for the Products.

1.3 User Responsibility: Due to the wide variety of operating conditions and applications for Hose, Tube and Fittings. Parker does not represent or warrant that any particular Hose, Tube or Fitting is suitable for any specific end use system. This safety guide does not analyze all technical parameters that must be considered in selecting a product. The user, through its own analysis and testing, is solely responsible for:

- Making the final selection of the Products.
- Assuring that the user's requirements are met and that the application presents no health or safety hazards.
- Following the safety guide for Related Accessories and being trained to operate Related Accessories.
- Providing all appropriate health and safety warnings on the equipment on which the Products are used.
- Assuring compliance with all applicable government and industry standards.

1.4 Additional Questions: Call the appropriate Parker technical service department if you have any questions or require any additional infor-

mation. See the Parker publication for the Products being considered or used, or call 1-800-CPARKER, or go to [www.parker.com](http://www.parker.com), for telephone numbers of the appropriate technical service department.

### 2.0 HOSE, TUBE AND FITTINGS SELECTION INSTRUCTIONS

2.1 Electrical Conductivity: Certain applications require that the Hose be nonconductive to prevent electrical current flow. Other applications require the Hose and the Fittings and the Hose/Fitting interface to be sufficiently conductive to drain off static electricity. Extreme care must be exercised when selecting Hose, Tube and Fittings for these or any other applications in which electrical conductivity or nonconductivity is a factor. The electrical conductivity or nonconductivity of Hose, Tube and Fittings is dependent upon many factors and may be susceptible to change. These factors include but are not limited to the various materials used to make the Hose and the Fittings, Fitting finish (some Fitting finishes are electrically conductive while others are nonconductive), manufacturing methods (including moisture control), how the Fittings contact the Hose, age and amount of deterioration or damage or other changes, moisture content of the Hose at any particular time, and other factors. The following are considerations for electrically nonconductive and conductive Hose. For other applications consult the individual catalog pages and the appropriate industry or regulatory standards for proper selection.

2.1.1 Electrically Nonconductive Hose: Certain applications require that the Hose be nonconductive to prevent electrical current flow or to maintain electrical isolation. For applications that require Hose to be electrically nonconductive, including but not limited to applications near high voltage electric lines, only special nonconductive Hose can be used. The manufacturer of the equipment in which the nonconductive Hose is to be used must be consulted to be certain that the Hose, Tube and Fittings that are selected are proper for the application. Do not use any Parker Hose or Fittings for any such application requiring nonconductive Hose, including but not limited to applications near high voltage electric lines or dense magnetic fields, unless (i) the application is expressly approved in the Parker technical publication for the product, (ii) the Hose is marked "nonconductive", and (iii) the manufacturer of the equipment on which the Hose is to be used specifically approves the particular Parker Hose, Tube and Fittings for such use.

2.1.2 Electrically Conductive Hose: Parker manufactures special Hose for certain applications that require electrically conductive Hose. Parker manufactures special Hose for conveying paint in airless paint spraying applications. This Hose is labeled "Electrically Conductive Airless Paint Spray Hose" on its layline and packaging. This Hose must be properly connected to the appropriate Parker Fittings and properly grounded in order to dissipate dangerous static charge buildup, which occurs in all airless paint spraying applications. Do not use any other Hose for airless paint spraying, even if electrically conductive. Use of any other Hose or failure to properly connect the Hose can cause a fire or an explosion resulting in death, personal injury, and property damage. All hoses that convey fuels must be grounded. Parker manufactures a special Hose for

## Technical Handbook

## Parker Safety Guide

certain compressed natural gas ("CNG") applications where static electricity buildup may occur. Parker CNG Hose assemblies comply with the requirements of ANSI/IAS NGV 4.2; CSA 12.52, "Hoses for Natural Gas Vehicles and Dispensing Systems" ([www.ansi.org](http://www.ansi.org)). This Hose is labeled "Electrically Conductive for CNG Use" on its layline and packaging. This Hose must be properly connected to the appropriate Parker Fittings and properly grounded in order to dissipate dangerous static charge buildup, which occurs in, for example, high velocity CNG dispensing or transfer. Do not use any other Hose for CNG applications where static charge buildup may occur, even if electrically conductive. Use of other Hoses in CNG applications or failure to properly connect or ground this Hose can cause a fire or an explosion resulting in death, personal injury, and property damage. Care must also be taken to protect against CNG permeation through the Hose wall. See section 2.6, Permeation, for more information. Parker CNG Hose is intended for dispenser and vehicle use within the specified temperature range. Parker CNG Hose should not be used in confined spaces or unventilated areas or areas exceeding the specified temperature range. Final assemblies must be tested for leaks. CNG Hose Assemblies should be tested on a monthly basis for conductivity per ANSI/IAS NGV 4.2; CSA 12.52. Parker manufactures special Hose for aerospace in-flight applications. Aerospace in-flight applications employing Hose to transmit fuel, lubricating fluids and hydraulic fluids require a special Hose with a conductive inner tube. This Hose for in-flight applications is available only from Parker's Stratoflex Products Division. Do not use any other Parker Hose for in-flight applications, even if electrically conductive. Use of other Hoses for in-flight applications or failure to properly connect or ground this Hose can cause a fire or an explosion resulting in death, personal injury and property damage. These Hose assemblies for in-flight applications must meet all applicable aerospace industry, aircraft engine and aircraft requirements.

**2.2 Pressure:** Hose, Tube and Fitting selection must be made so that the published maximum working pressure of the Hose, Tube and Fittings are equal to or greater than the maximum system pressure. The maximum working pressure of a Hose, or Tube Assembly is the lower of the respective published maximum working pressures of the Hose, Tube and the Fittings used. Surge pressures or peak transient pressures in the system must be below the published maximum working pressure for the Hose, Tube and Fitting. Surge pressures and peak pressures can usually only be determined by sensitive electrical instrumentation that measures and indicates pressures at millisecond intervals. Mechanical pressure gauges indicate only average pressures and cannot be used to determine surge pressures or peak transient pressures. Published burst pressure ratings for Hose is for manufacturing test purposes only and is no indication that the Product can be used in applications at the burst pressure or otherwise above the published maximum recommended working pressure.

**2.3 Suction:** Hoses used for suction applications must be selected to insure that the Hose will withstand the vacuum and pressure of the system. Improperly selected Hose may collapse in suction application.

**2.4 Temperature:** Be certain that fluid and ambient temperatures, both steady and transient, do not exceed the limitations of the Hose, Tube, Fitting and Seals. Temperatures below and above the recommended limit can degrade Hose, Tube, Fittings and Seals to a point where a failure may occur and release fluid. Tube and Fittings performances are normally degraded at elevated temperature. Material compatibility can also change at temperatures outside of the rated range. Properly insulate and protect the Hose Assembly when routing near hot objects (e.g. manifolds). Do not use any Hose in any application where failure of the Hose could result in the conveyed fluids (or vapors or mist from the conveyed fluids) contacting any open flame, molten metal, or other potential fire ignition source that could cause burning or explosion of the conveyed fluids or vapors.

**2.5 Fluid Compatibility:** Hose, and Tube Assembly selection must assure compatibility of the Hose tube, cover, reinforcement, Tube, Plating and Seals with the fluid media used. See the fluid compatibility chart in the Parker publication for the product being considered or used. This information is offered only as a guide. Actual service life can only be determined by the end user by testing under all extreme conditions and other analysis. Hose, and Tube that is chemically compatible with a particular fluid must be assembled using Fittings and adapters containing likewise compatible seals. Flange or flare processes can change Tube material properties that may not be compatible with certain requirements such as NACE

**2.6 Permeation:** Permeation (that is, seepage through the Hose or Seal) will occur from inside the Hose or Fitting to outside when Hose

or Fitting is used with gases, liquid and gas fuels, and refrigerants (including but not limited to such materials as helium, diesel fuel, gasoline, natural gas, or LPG). This permeation may result in high concentrations of vapors which are potentially flammable, explosive, or toxic, and in loss of fluid. Dangerous explosions, fires, and other hazards can result when using the wrong Hose for such applications. The system designer must take into account the fact that this permeation will take place and must not use Hose or Fitting if this permeation could be hazardous. The system designer must take into account all legal, government, insurance, or any other special regulations which govern the use of fuels and refrigerants. Never use a Hose or Fitting even though the fluid compatibility is acceptable without considering the potential hazardous effects that can result from permeation through the Hose or Tube Assembly. Permeation of moisture from outside the Hose or Fitting to inside the Hose or Fitting will also occur in Hose or Tube assemblies, regardless of internal pressure. If this moisture permeation would have detrimental effects (particularly, but not limited to refrigeration and air conditioning systems), incorporation of sufficient drying capacity in the system or other appropriate system safeguards should be selected and used. The sudden pressure release of highly pressurized gas could also result in Explosive Decompression failure of permeated Seals and Hoses.

**2.7 Size:** Transmission of power by means of pressurized fluid varies with pressure and rate of flow. The size of the components must be adequate to keep pressure losses to a minimum and avoid damage due to heat generation or excessive fluid velocity.

**2.8 Routing:** Attention must be given to optimum routing to minimize inherent problems (kinking or flow restriction due to Hose collapse, twisting of the Hose, proximity to hot objects or heat sources). For additional routing recommendations see SAE J1273 and ISO 17165-2. Hose Assemblies have a finite life and should be installed in a manner that allows for ease of inspection and future replacement. Hose because of its relative short life, should not be used in residential and commercial buildings inside of inaccessible walls or floors, unless specifically allowed in the product literature. Always review all product literature for proper installation and routing instructions.

**2.9 Environment:** Care must be taken to insure that the Hose, Tube and Fittings are either compatible with or protected from the environment (that is, surrounding conditions) to which they are exposed. Environmental conditions including but not limited to ultraviolet radiation, sunlight, heat, ozone, moisture, water, salt water, chemicals and air pollutants can cause degradation and premature failure.

**2.10 Mechanical Loads:** External forces can significantly reduce Hose, Tube and Fitting life or cause failure. Mechanical loads which must be considered include excessive flexing, twist, kinking, tensile or side loads, bend radius, and vibration. Use of swivel type Fittings or adapters may be required to insure no twist is put into the Hose. Use of proper Hose or Tube clamps may also be required to reduce external mechanical loads. Unusual applications may require special testing prior to Hose selection.

**2.11 Physical Damage:** Care must be taken to protect Hose from wear, snagging, kinking, bending smaller than minimum bend radius and cutting, any of which can cause premature Hose failure. Any Hose that has been kinked or bent to a radius smaller than the minimum bend radius, and any Hose that has been cut or is cracked or is otherwise damaged should be removed and discarded. Fittings with damages such as scratches on sealing surfaces and deformation should be replaced.

**2.12 Proper End Fitting:** See instructions 3.2 through 3.5. These recommendations may be substantiated by testing to industry standards such as SAE J517 for hydraulic applications, or MIL-A-5070, AS1339, or AS3517 for Hoses from Parker's Stratoflex Products Division for aerospace applications.

**2.13 Length:** When determining the proper Hose or Tube length of an assembly, be aware of Hose length change due to pressure, Tube length change due to thermal expansion or contraction, and Hose or Tube and machine tolerances and movement must be considered. When routing short hose assemblies, it is recommended that the minimum free hose length is always used. Consult the hose manufacturer for their minimum free hose length recommendations. Hose assemblies should be installed in such a way that any motion or flexing occurs within the same plane.

**2.14 Specifications and Standards:** When selecting Hose, Tube and Fittings, government, industry, and Parker specifications and recommendations must be reviewed and followed as applicable.

**2.15 Hose Cleanliness:** Hose and Tube components may vary in cleanliness levels. Care must be taken to insure that the Hose and

## Parker Safety Guide

Tube Assembly selected has an adequate level of cleanliness for the application.

**2.16 Fire Resistant Fluids:** Some fire resistant fluids that are to be conveyed by Hose or Tube require use of the same type of Hose or Tube as used with petroleum base fluids. Some such fluids require a special Hose, Tube, Fitting and Seal, while a few fluids will not work with any Hose at all. See instructions 2.5 and 1.5. The wrong Hose, Tube, Fitting or Seal may fail after a very short service. In addition, all liquids but pure water may burn fiercely under certain conditions, and even pure water leakage may be hazardous.

**2.17 Radiant Heat:** Hose and Seals can be heated to destruction without contact by such nearby items as hot manifolds or molten metal. The same heat source may then initiate a fire. This can occur despite the presence of cool air around the Hose or Seal. Performance of Tube and Fitting subjected to the heat could be degraded.

**2.18 Welding or Brazing:** When using a torch or arc welder in close proximity to hydraulic lines, the hydraulic lines should be removed or shielded with appropriate fire resistant materials. Flame or weld spatter could burn through the Hose or Seal and possibly ignite escaping fluid resulting in a catastrophic failure. Heating of plated parts, including Hose Fittings and adapters, above 450°F (232°C) such as during welding, brazing or soldering may emit deadly gases. Any elastomer seal on fittings shall be removed prior to welding or brazing, any metallic surfaces shall be protected after brazing or welding when necessary. Welding and brazing filler material shall be compatible with the Tube and Fitting that are joined.

**2.19 Atomic Radiation:** Atomic radiation affects all materials used in Hose and Tube assemblies. Since the long-term effects may be unknown, do not expose Hose or Tube assemblies to atomic radiation. Nuclear applications may require special Tube and Fittings.

**2.20 Aerospace Applications:** The only Hose, Tube and Fittings that may be used for in-flight aerospace applications are those available from Parker's Stratoflex Products Division. Do not use any other Hose or Fittings for in-flight applications. Do not use any Hose or Fittings from Parker's Stratoflex Products Division with any other Hose or Fittings, unless expressly approved in writing by the engineering manager or chief engineer of Stratoflex Products Division and verified by the user's own testing and inspection to aerospace industry standards.

**2.21 Unlocking Couplings:** Ball locking couplings or other Fittings with quick disconnect ability can unintentionally disconnect if they are dragged over obstructions, or if the sleeve or other disconnect member, is bumped or moved enough to cause disconnect. Threaded Fittings should be considered where there is a potential for accidental uncoupling.

### 3.0 HOSE AND FITTINGS ASSEMBLY AND INSTALLATION INSTRUCTIONS

**3.1 Component Inspection:** Prior to assembly, a careful examination of the Hose and Fittings must be performed. All components must be checked for correct style, size, catalog number, and length. The Hose must be examined for cleanliness, obstructions, blisters, cover looseness, kinks, cracks, cuts or any other visible defects. Inspect the Fitting and sealing surfaces for burrs, nicks, corrosion or other imperfections. Do NOT use any component that displays any signs of nonconformance.

**3.2 Hose and Fitting Assembly:** Do not assemble a Parker Fitting on a Parker Hose that is not specifically listed by Parker for that Fitting, unless authorized in writing by the engineering manager or chief engineer of the appropriate Parker division. Do not assemble a Parker Fitting on another manufacturer's Hose or a Parker Hose on another manufacturer's Fitting unless (i) the engineering manager or chief engineer of the appropriate Parker division approves the Assembly in writing or that combination is expressly approved in the appropriate Parker literature for the specific Parker product, and

(ii) the user verifies the Assembly and the application through analysis and testing. For Parker Hose that does not specify a Parker Fitting, the user is solely responsible for the selection of the proper Fitting and Hose Assembly procedures. See instruction 1.4. To prevent the possibility of problems such as leakage at the Fitting or system contamination, it is important to completely remove all debris from the cutting operation before installation of the Fittings. The Parker published instructions must be followed for assembling the Fittings on the Hose. These instructions are provided in the Parker Fitting catalog for the specific Parker Fitting being used, or by calling 1-800-CPARKER, or at [www.parker.com](http://www.parker.com).

**3.3 Related Accessories:** Do not crimp or swage any Parker Hose or Fitting with anything but the listed swage or crimp machine and dies

in accordance with Parker published instructions. Do not crimp or swage another manufacturer's Fitting with a Parker crimp or swage die unless authorized in writing by the engineering manager or chief engineer of the appropriate Parker division.

**3.4 Parts:** Do not use any Parker Fitting part (including but not limited to socket, shell, nipple, or insert) except with the correct Parker mating parts, in accordance with Parker published instructions, unless authorized in writing by the engineering manager or chief engineer of the appropriate Parker division.

**3.5 Field Attachable/Permanent:** Do not reuse any field attachable Hose Fitting that has blown or pulled off a Hose. Do not reuse a Parker permanent Hose Fitting (crimped or swaged) or any part thereof. Complete Hose Assemblies may only be reused after proper inspection under section 4.0. Do not assemble Fittings to any previously used hydraulic Hose that was in service, for use in a fluid power application.

**3.6 Pre-Installation Inspection:** Prior to installation, a careful examination of the Hose Assembly must be performed. Inspect the Hose Assembly for any damage or defects. DO NOT use any Hose Assembly that displays any signs of nonconformance.

**3.7 Minimum Bend Radius:** Installation of a Hose at less than the minimum listed bend radius may significantly reduce the Hose life. Particular attention must be given to preclude sharp bending at the Hose to Fitting juncture. Any bending during installation at less than the minimum bend radius must be avoided. If any Hose is kinked during installation, the Hose must be discarded.

**3.8 Twist Angle and Orientation:** Hose Assembly installation must be such that relative motion of machine components does not produce twisting.

**3.9 Securement:** In many applications, it may be necessary to restrain, protect, or guide the Hose to protect it from damage by unnecessary flexing, pressure surges, and contact with other mechanical components. Care must be taken to insure such restraints do not introduce additional stress or wear points.

**3.10 Proper Connection of Ports:** Proper physical installation of the Hose Assembly requires a correctly installed port connection insuring that no twist or torque is transferred to the Hose when the Fittings are being tightened or otherwise during use.

**3.11 External Damage:** Proper installation is not complete without insuring that tensile loads, side loads, kinking, flattening, potential abrasion, thread damage or damage to sealing surfaces are corrected or eliminated. See instruction 2.10.

**3.12 System Checkout:** All air entrapment must be eliminated and the system pressurized to the maximum system pressure (at or below the Hose maximum working pressure) and checked for proper function and freedom from leaks. Personnel must stay out of potential hazardous areas while testing and using.

**3.13 Routing:** The Hose Assembly should be routed in such a manner so if a failure does occur, the escaping media will not cause personal injury or property damage. In addition, if fluid media comes in contact with hot surfaces, open flame or sparks, a fire or explosion may occur. See section 2.4.

**3.14 Ground Fault Equipment Protection Devices (GFEEDs):** WARNING! Fire and Shock Hazard. To minimize the danger of fire if the heating cable of a Multitube bundle is damaged or improperly installed, use a Ground Fault Equipment Protection Device. Electrical fault currents may be insufficient to trip a conventional circuit breaker. For ground fault protection, the IEEE 515: ([www.ansi.org](http://www.ansi.org)) standard for heating cables recommends the use of GFEEDs with a nominal 30 milliampere trip level for "piping systems in classified areas, those areas requiring a high degree of maintenance, or which may be exposed to physical abuse or corrosive atmospheres".

### 4.0 TUBE AND FITTINGS ASSEMBLY AND INSTALLATION INSTRUCTIONS

**4.1 Component Inspection:** Prior to assembly, a careful examination of the Tube and Fittings must be performed. All components must be checked for correct style, size, material, seal, and length. Inspect the Fitting and sealing surfaces for burrs, nicks, corrosion, missing seal or other imperfections. Do NOT use any component that displays any signs of nonconformance.

**4.2 Tube and Fitting Assembly:** Do not assemble a Parker Fitting with a Tube that is not specifically listed by Parker for that Fitting, unless authorized in writing by the engineering manager or chief engineer of the appropriate Parker division. The Tube must meet the requirements specified to the Fitting. The Parker published instructions must

## Technical Handbook

## Parker Safety Guide

be followed for assembling the Fittings to a Tube. These instructions are provided in the Parker Fitting catalog for the specific Parker Fitting being used, or by calling 1-800-CPARKER, or at [www.parker.com](http://www.parker.com).

**4.3 Related Accessories:** Do not preset or flange Parker Fitting components using another manufacturer's equipment or procedures unless authorized in writing by the engineering manager or chief engineer of the appropriate Parker division. Tube, Fitting component and tooling must be checked for correct style, size and material. Operation and maintenance of Related Accessories must be in accordance with the operation manual for the designated Accessory.

**4.4 Securement:** In many applications, it may be necessary to restrain, protect, or guide the Tube to protect it from damage by unnecessary flexing, pressure surges, vibration, and contact with other mechanical components. Care must be taken to insure such restraints do not introduce additional stress or wear points.

**4.5 Proper Connection of Ports:** Proper physical installation of the Tube Assembly requires a correctly installed port connection insuring that no torque is transferred to the Tube when the Fittings are being tightened or otherwise during use.

**4.6 External Damage:** Proper installation is not complete without insuring that tensile loads, side loads, flattening, potential abrasion, thread damage or damage to sealing surfaces are corrected or eliminated. See instruction 2.10.

**4.7 System Checkout:** All air entrapment must be eliminated and the system pressurized to the maximum system pressure (at or below the Tube Assembly maximum working pressure) and checked for proper function and freedom from leaks. Personnel must stay out of potential hazardous areas while testing and using.

**Routing:** The Tube Assembly should be routed in such a manner so if a failure does occur, the escaping media will not cause personal injury or property damage. In addition, if fluid media comes in contact with hot surfaces, open flame or sparks, a fire or explosion may occur. See section 2.4.

### 5.0 HOSE AND FITTING MAINTENANCE AND REPLACEMENT INSTRUCTIONS

**5.1 Even with proper selection and installation, Hose life may be significantly reduced without a continuing maintenance program. The severity of the application, risk potential from a possible Hose failure, and experience with any Hose failures in the application or in similar applications should determine the frequency of the inspection and the replacement for the Products so that Products are replaced before any failure occurs. Certain products require maintenance and inspection per industry requirements. Failure to adhere to these requirements may lead to premature failure. A maintenance program must be established and followed by the user and, at minimum, must include instructions 5.2 through 5.7**

**5.2 Visual Inspection Hose/Fitting:** Any of the following conditions require immediate shut down and replacement of the Hose Assembly:

- Fitting slippage on Hose;
- Damaged, cracked, cut or abraded cover (any reinforcement exposed);
- Hard, stiff, heat cracked, or charred Hose;
- Cracked, damaged, or badly corroded Fittings;
- Leaks at Fitting or in Hose;
- Kinked, crushed, flattened or twisted Hose; and
- Blistered, soft, degraded, or loose cover.

**5.3 Visual Inspection All Other:** The following items must be tightened, repaired, corrected or replaced as required:

- Leaking port conditions;
- Excess dirt buildup;
- Worn clamps, guards or shields; and
- System fluid level, fluid type, and any air entrapment.

**5.4 Functional Test:** Operate the system at maximum operating pressure and check for possible malfunctions and leaks. Personnel must avoid potential hazardous areas while testing and using the system. See section 2.2.

**5.5 Replacement Intervals:** Hose assemblies and elastomeric seals used on Hose Fittings and adapters will eventually age, harden, wear and deteriorate under thermal cycling and compression set. Hose Assemblies and elastomeric seals should be inspected and replaced at specific replacement intervals, based on previous service life, government or industry recommendations, or when failures could result in unacceptable downtime, damage, or injury risk. See section 1.2. Hose and Fittings may be subjected to internal mechanical and/or chemical wear from the conveying fluid and may fail without warning. The user must determine the product life under such circumstances by testing. Also see section 2.5.

**5.6 Hose Inspection and Failure:** Hydraulic power is accomplished by utilizing high pressure fluids to transfer energy and do work. Hoses, Fittings and Hose Assemblies all contribute to this by transmitting fluids at high pressures. Fluids under pressure can be dangerous and potentially lethal and, therefore, extreme caution must be exercised when working with fluids under pressure and handling the Hoses transporting the fluids. From time to time, Hose Assemblies will fail if they are not replaced at proper time intervals. Usually these failures are the result of some form of misapplication, abuse, wear or failure to perform proper maintenance. When Hoses fail, generally the high pressure fluids inside escape in a stream which may or may not be visible to the user. Under no circumstances should the user attempt to locate the leak by "feeling" with their hands or any other part of their body. High pressure fluids can and will penetrate the skin and cause severe tissue damage and possibly loss of limb. Even seemingly minor hydraulic fluid injection injuries must be treated immediately by a physician with knowledge of the tissue damaging properties of hydraulic fluid.

If a Hose failure occurs, immediately shut down the equipment and leave the area until pressure has been completely released from the Hose Assembly. Simply shutting down the hydraulic pump may or may not eliminate the pressure in the Hose Assembly. Many times check valves, etc., are employed in a system and can cause pressure to remain in a Hose Assembly even when pumps or equipment are not operating. Tiny holes in the Hose, commonly known as pinholes, can eject small, dangerously powerful but hard to see streams of hydraulic fluid. It may take several minutes or even hours for the pressure to be relieved so that the Hose Assembly may be examined safely. Once the pressure has been reduced to zero, the Hose Assembly may be taken off the equipment and examined. It must always be replaced if a failure has occurred. Never attempt to patch or repair a Hose Assembly that has failed. Consult the nearest Parker distributor or the appropriate Parker division for Hose Assembly replacement information. Never touch or examine a failed Hose Assembly unless it is obvious that the Hose no longer contains fluid under pressure. The high pressure fluid is extremely dangerous and can cause serious and potentially fatal injury.

**5.7 Elastomeric seals:** Elastomeric seals will eventually age, harden, wear and deteriorate under thermal cycling and compression set. Elastomeric seals should be inspected and replaced.

**5.8 Refrigerant gases:** Special care should be taken when working with refrigeration systems. Sudden escape of refrigerant gases can cause blindness if the escaping gases contact the eye and can cause freezing or other severe injuries if it contacts any other portion of the body.

**5.9 Compressed natural gas (CNG):** Parker CNG Hose Assemblies should be tested after installation and before use, and at least on a monthly basis per instructions provided on the Hose Assembly tag. The recommended procedure is to pressurize the Hose and check for leaks and to visually inspect the Hose for damage and to perform an electrical resistance test.

**Caution:** Matches, candles, open flame or other sources of ignition shall not be used for Hose inspection. Leak check solutions should be rinsed off after use.

### 6.0 HOSE STORAGE

**6.1 Age Control:** Hose and Hose Assemblies must be stored in a manner that facilitates age control and first-in and first-out usage based on manufacturing date of the Hose and Hose Assemblies. Unless otherwise specified by the manufacturer or defined by local laws and regulations:

**6.1.1** The shelf life of rubber hose in bulk form or hose made from two or more materials is 28 quarters (7 years) from the date of manufacture, with an extension of 12 quarters (3 years), if stored in accordance with ISO 2230;

**6.1.2** The shelf life of thermoplastic and polytetrafluoroethylene hose is considered to be unlimited;

**6.1.3** Hose assemblies that pass visual inspection and proof test shall not be stored for longer than 2 years.

**6.1.4 Storage:** Stored Hose and Hose Assemblies must not be subjected to damage that could reduce their expected service life and must be placed in a cool, dark and dry area with the ends capped. Stored Hose and Hose Assemblies must not be exposed to temperature extremes, ozone, oils, corrosive liquids or fumes, solvents, high humidity, rodents, insects, ultraviolet light, electromagnetic fields or radioactive materials.

# Critical Applications

## Safety Overview

It is important to employ safe practices in the use of industrial hose due to the number of potentially dangerous applications encountered and products conveyed, and the number of people that may be involved or exposed. Strictly observe these simple practices to help avoid accidents.

- **Training:** Train all operators thoroughly
- **Evaluation:** Evaluate the application to determine the hose performance requirements
- **Selection:** Select the most appropriate hose and couplings for the application; ensure that the couplings are compatible with the media and hose, and securely attached to the hose
- **Service:** Regularly inspect and maintain both the hose and couplings while in service

While many industrial hose applications are potentially dangerous, some are of particular concern because their danger may not be readily apparent. This is especially true for applications involving untrained or inexperienced operators.

## Aircraft Fueling Hose

Use only API/ISO qualified hose for aircraft fueling applications. Aircraft fueling hose incorporates high grade rubber compounds that dissipate static charges and will not contaminate fuel.

**Note:** To avoid fuel contamination do not use gasoline dispenser or farm pump hose to fuel aircraft.

## Anhydrous Ammonia (NH<sub>3</sub>) Hose

Many accidents involving anhydrous ammonia occur due to selection of an incorrect hose for the application. Anhydrous ammonia hose must be specially designed and compounded to handle the media, with a perforated cover to prevent gas build-up amidst the layers of hose.

**WARNING!** Use ONLY anhydrous ammonia hose for anhydrous ammonia service. Contact with anhydrous ammonia in its liquid or gaseous (vapor) phase will burn skin, eyes and lungs, causing serious bodily injury or death.

- Do not use anhydrous ammonia hose for LPG service. It may fail suddenly and quickly. Anhydrous ammonia hose and LPG hose are frequently used in proximity and may be accidentally switched.
- Do not use with couplings containing o-rings, which may dry out, crack and fail over time. Do not use with male swivel couplings or other couplings containing hidden o-rings.

Anhydrous ammonia hose is designed to allow a limited amount of permeation of gas through the wall of the hose when in service, and staining of the hose cover in the pinpricked areas does not necessarily indicate leakage for a hose in service. However, a visible gas mist escaping through the hose is an indication of leakage.

To verify the integrity of a hose in service, perform a hydrostatic test on the assembly; immediately remove from service any that fail the test.

**Note:** For non-agricultural or refrigeration applications, contact Parker.



## Technical Handbook

### Chemical Hose

A chemical hose system failure could cause the release of poisonous, corrosive, or flammable material resulting in property damage, serious bodily injury or death. All reputable manufacturers of chemical hose recommend specific hose constructions to handle various chemicals.

Refer to the chemical guides in this catalog, or contact Parker for technical assistance before using or recommending a hose product.

#### Handling

- Use care to prevent mishandling. Crushing or kinking of the hose can cause severe damage to the reinforcement.
- Use proper hose suspension equipment when lifting or dragging a hose to ensure that the recommended curvature is not exceeded. Avoid sharp bends at the end fittings and at manifold connections.

#### Operation

- Use safety precautions such as wearing eye or face protection, rubber gloves, boots, and other types of protective clothing.

- Monitor pressures and temperatures to ensure that the hose is not exposed to conditions above specified limits.
- Do not allow chemicals to contact the exterior of the hose or allow hose to lie in a pool of chemicals since the hose cover may not have the same level of corrosion resistance as the tube. Corrosive materials that come into contact with the reinforcing material will cause reduced service life and premature hose failure.

#### Temperature

Do not use chemical hose at pressures or temperatures exceeding those as specified for the product. Many chemical resistance guides are based on temperatures of 70°F (21°C). Elevated temperatures can change the chemical resistance ratings. Many chemicals will become more aggressive as temperatures increase, reducing the ability of hose compounds to withstand them. Contact Parker for chemical compatibility data at elevated temperatures. If no data exists, end users are required to perform compatibility testing at the desired temperature.

### Gasoline Dispenser Hose

Millions of consumers operate gasoline pumps every day, increasing the concern for the safe use of dispensing equipment, including the hose. Since gasoline dispenser hoses are subject to frequent abuse, hose selection must include consideration of the rigors of the application. For maximum service life, select only the highest quality.

**Note:** To avoid fuel contamination do not use gasoline dispenser or farm pump hose to fuel aircraft.

### LP Gas (Propane) Hose

Many accidents involving LP Gas occur due to selection of an incorrect hose for the application. LP Gas hose must be specially designed and compounded to handle the media, with a perforated cover to prevent gas build-up amidst the layers of the hose.

**WARNING!** Use ONLY LP Gas hose for LP Gas service. LP Gas possesses volatile characteristics that may produce fire or explosions causing property damage, serious bodily injury or death.

- Do not use LP Gas hose for anhydrous ammonia service. It may fail suddenly and quickly. Anhydrous ammonia hose and LPG hose are frequently used in proximity and may be accidentally switched.
- Do not use with couplings containing o-rings, which may dry out, crack and fail over time. Do not use with male swivel couplings or other couplings containing hidden o-rings.

LP Gas hose is designed to allow a limited amount of permeation of LP Gas through the wall of the hose when in service. The permeation is apparent when the hose is moist or in water, and bubbles may be perceived as leakage. However, a legitimate propane leak creates a frosting or icing on the surface of the hose or coupling.

To verify the integrity of a hose in service, perform a hydrostatic test on the assembly; immediately remove from service any hose that fails the test.

## Natural Gas and LP Gas Hose

The molecules of natural gas are small, enhancing their ability to permeate through standard rubber or PVC hose constructions. The permeation process is more rapid as the working pressure increases, and natural gas accumulates with potentially dangerous consequences.

- Use only in a well-ventilated environment: Outdoors, or indoors with significant continuous air movement.
- Do not use LP Gas hose to replace fixed/rigid pipe where that material is more appropriate due to reduced permeation, overall strength and durability. Use rigid pipe, non-permeable tubing or hose with barrier constructions to convey natural gas whenever possible.

## Petroleum Transfer Hose

- Do not use for oil or fuel transfer service in or on open water. Hose damage or failure may result in spillage and environmental damage. Use hose specifically designed for this application.
- Do not immerse in fuel. The hose cover compound may not be of sufficient grade to resist attack by the fuel. Use hose specifically designed for this application.

## Steam Hose

Water changes to hot water and phases of steam when subjected to heat and pressure. The greater the pressure, the higher the temperature required to achieve and maintain a steam phase. If steam escapes, dangerous quantities of heat may be released very suddenly.

**WARNING!** Hot water, low pressure steam and high pressure steam may escape explosively and will scald skin, eyes and lungs, which may lead to severe bodily injury or death.

- Many steam systems incorporate detergents or rust inhibitors which may attack steam hose. Prior to using a steam hose with detergents or rust inhibitors, refer to the chemical guides in this catalog, or contact Parker.
- Drain steam hose after each use to reduce the possibility of hose popcorning while in service.

The chart at the right represents the three forms of water when subjected to various combinations of heat and pressure. The red line represents the point at which hot water becomes saturated steam. The area below the red line is hot water; the area above the red line is superheated steam.

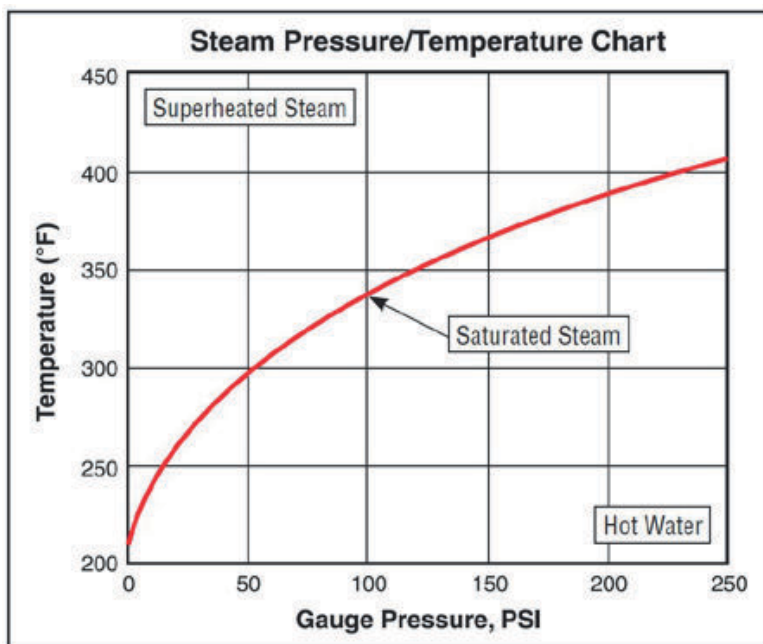

## Technical Handbook

### Welding Hose

Many accidents involving welding hose occur due to selection of an incorrect hose for the application. Welding hose must be specially designed and compounded to handle the media. Due to the extreme volatility of gases, the varying compatibility of gases with the various grades of hose, and the rough environment of many welding applications, it is crucial to select the correct welding hose.

**WARNING!** Welding gases possess volatile characteristics that may produce fire or explosions causing property damage, serious bodily injury or death.

- Replace all assemblies that show signs of abrading, abuse, age, damage or fatigue. Do not attempt to recouple, repair or splice hose assemblies.
- Fabricate hose assemblies using only crimped-on ferrules at least 25 mm long to ensure coverage and support of the coupling stem inside the hose.
- Couplings attached with bands or clamps may reduce the working pressure of the hose assembly to less than the maximum rated working pressure of the hose.

### PVC / Thermoplastic Hose

Thermoplastic polymer compounds are designed to resist deterioration when exposed to a wide range of commercial chemicals and environmental conditions. The resistance to attack is based on many factors, including temperature, pressure, chemical concentration, exposure to ultraviolet light, velocity of the media and duration of exposure/ service (intermittent or constant). The user is solely responsible for making the final selection of the hose and tubing, and meeting all endurance, maintenance, performance, safety and warning requirements of the application.

**WARNING!** As temperature increases or decreases, burst pressure, safe working pressure, coupling retention properties, and other safety characteristics of the hose can significantly decrease. Failure to consider how temperature and other conditions affect hose performance may cause property damage, serious bodily injury or death.



## Oil & Fuel



 Oil & Fuel

## A – Oil & Fuel

Hose	ID Range (mm)	Temp. Range (°C)	Application
CARBOPRESS N/L 10	5 - 25	-25 / +80	fuel, oil, petrol aromatic < 50 %
CARBOPRESS N/L 20	6 - 25	-25 / +80	fuel, oil, petrol aromatic < 50 %
CARBURITE 10	19 - 150	-30 / +80	fuel, oil, petrol aromatic < 50 %
CARBOCORD EN 12115	19 - 100	-25 / +80	fuel, oil, petrol aromatic < 50 %
CHEMIOEL EN 12115	19 - 100	-25 / +80	fuel, oil, petrol aromatic < 50 %
CERVINO EN 12115	50 - 100	-40 / +80	fuel, oil, petrol aromatic < 50 %
E-Z FORM™ HT	12.7 - 25.4	-40 / +150	petro.-based oil suc./ret. line, power steer



	Tube	Reinforce- ment	Cover	WP (bar)	Design Factor	Suction	Industry standard	Page
	NBR	textile	NBR/EPDM	10	3			A4
	NBR	textile	NBR/EPDM	20	3			A4
	NBR	textile	NBR/SBR	10	3	yes		A5
	NBR	textile + copper wires	NBR/SBR	16	4		EN 12115	A6
	NBR	textile + copper wires	NBR/SBR	16	4	yes	EN 12115	A7
	NBR	textile + copper wires	NBR/SBR	16	4	yes	EN 12115	A8
earing	CPE	textile	HNBR	10	4	yes		A9

 Oil & Fuel

## CARBOPRESS N/L 10 - 20

Suitable for fuel oils, petrol and diesel having an aromatic content not exceeded 50 % and also for grease.

### Hose Construction

**Tube:** Black, smooth, NBR rubber compound  
**Reinforcement:** Synthetic textile yarns  
**Cover:** Black, smooth, abrasion, oil, fuel, and weather-resistant, antistatic (R < 1 MΩ/m) special NBR/EPDM rubber compound

### Temperature Range

-25 °C (-13 °F) to +80 °C (+176 °F)  
up to +100 °C (+212 °F) for oil



- Dual pressure lines
- Also suitable for water and air in general service applications
- Design Factor 3:1
- B100 compatible





### Tolerances

According to UNI EN ISO 1307  
Refer to Technical Handbook on page TH35

### Fitting Series

64 + 47

***Bold-Italic printed part numbers are stock products.***

Part Number								in Stock
	I.D. (mm)	O.D. (mm)	MPa	psi	bar			
<b>CARBOPRESS N/L 10</b>								
<b><i>IH30501001/100</i></b>	5	12	1.0	150.0	10	0.12	40	Y
<b><i>IH30511003/100</i></b>	6	12	1.0	150.0	10	0.11	50	Y
<b><i>IH30511002/100</i></b>	6	13	1.0	150.0	10	0.14	50	Y
<b><i>IH30501002/100</i></b>	8	15	1.0	150.0	10	0.17	65	Y
<b><i>IH30501003/100</i></b>	10	17	1.0	150.0	10	0.20	80	Y
<b><i>IH30501004/100</i></b>	13	20	1.0	150.0	10	0.24	105	Y
<b><i>IH30511004/100</i></b>	16	23	1.0	150.0	10	0.29	130	Y
<b><i>IH30501006/40</i></b>	19	27	1.0	150.0	10	0.39	150	Y
<b><i>IH30501007/50</i></b>	25	35	1.0	150.0	10	0.63	200	Y
<b>CARBOPRESS N/L 20</b>								
<b><i>IH30502001/100</i></b>	6	14	2.0	300.0	20	0.17	50	Y
<b><i>IH30502002/100</i></b>	8	17	2.0	300.0	20	0.24	65	Y
<b><i>IH30502003/100</i></b>	10	19	2.0	300.0	20	0.27	80	Y
IH30512006/100	13	23	2.0	300.0	20	0.38	105	N
<b><i>IH30512010/40</i></b>	16	26	2.0	300.0	20	0.44	130	Y
IH30512007/40	19	30	2.0	300.0	20	0.57	150	N
IH30512009/40	25	36	2.0	300.0	20	0.71	200	N

Hose layline example

RUBBER HOSE CARBOPRESS W.P. bar





## CARBURITE 10

Designed for suction and delivery of mineral oils and fuels (with aromatic content not exceeding 50 %) in road and rail tankers, service stations and refineries.

### Hose Construction

- Tube:** Black, smooth, NBR rubber compound, resistant to oil and fuel with an aromatic content not exceeding 50 %
- Reinforcement:** Synthetic textile fabrics and embedded steel wire helix
- Cover:** Black, smooth, antistatic (R < 1 MΩ/m) NBR/SBR rubber compound, oil, fuel, abrasion, ageing and weather resistant

### Temperature Range

-30 °C (-22 °F) to +80 °C (+176 °F)  
up to +100 °C (+212 °F) for oil



- Also suitable for water and air in general service applications
- Crimped solution with 48 series and Large Bore series
- Vacuum 0.8 bar (600 mm Hg)
- Design Factor 3:1

### Tolerances

According to RMA steel mandrel  
Refer to Technical Handbook on page TH35

### Fitting Series

48 (up to I.D. 50 mm)  
IF (from I.D. 60 mm)

***Bold-Italic printed part numbers are stock products.***

Part Number	I.D. (mm)	O.D. (mm)	Max. Working Pressure			Weight kg/m	min. Bend Radius mm	in Stock
			MPa	psi	bar			
<i>IH36530099/40</i>	19	29	1.0	150.0	10	0.61	120	Y
<i>IH36531004/40</i>	25	35	1.0	150.0	10	0.80	150	Y
<i>IH36530201/40</i>	30	40	1.0	150.0	10	0.92	180	Y
<i>IH36531012/40</i>	32	42	1.0	150.0	10	0.98	190	Y
<i>IH36530202/40</i>	35	45	1.0	150.0	10	1.05	210	Y
<i>IH36531002/40</i>	38	48	1.0	150.0	10	1.13	240	Y
<i>IH36530203/40</i>	40	50	1.0	150.0	10	1.18	240	Y
IH36530212/40	42	52	1.0	150.0	10	1.22	252	Y
<i>IH36530204/40</i>	45	55	1.0	150.0	10	1.31	270	Y
<i>IH36530205/40</i>	50	60	1.0	150.0	10	1.46	300	Y
<i>IH36530206/40</i>	60	71	1.0	150.0	10	1.89	360	Y
<i>IH36531001/40</i>	63.5	75	1.0	150.0	10	2.09	380	Y
<i>IH36530207/20</i>	70	82	1.0	150.0	10	2.47	420	Y
<i>IH36530208/20</i>	75	87	1.0	150.0	10	2.68	450	Y
<i>IH36530209/20</i>	80	92	1.0	150.0	10	2.84	480	Y
<i>IH36531003/20</i>	90	104	1.0	150.0	10	3.64	540	Y
<i>IH36530211/20</i>	100	114	1.0	150.0	10	4.02	600	Y
<i>IH36531019/20</i>	110	124	1.0	150.0	10	4.29	660	Y
IH36531050/10	150	170	1.0	150.0	10	7.27	900	N

Hose layline example





 Oil & Fuel

## CARBOCORD EN 12115

According to EN 12115

*Suitable for delivery of oil and fuel with an aromatic content not exceeding 50 %.*

### Hose Construction

**Tube:** Black, smooth, NBR rubber compound, resistant to oil and fuel with an aromatic content not exceeding 50 %.

**Reinforcement:** Synthetic textile fabrics and built-in copper wires to provide electrical continuity between both ends.

**Cover:** Black, smooth, NBR/SBR rubber compound, antistatic ( $R < 1 \text{ M}\Omega/\text{m}$ ), oil, fuel, abrasion, ageing and weather resistant.

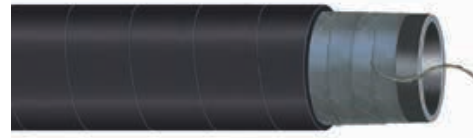

- Meets TRbF 131 Teil 2 par 5.5 (flame resistance)
- Optimal for tank truck application
- Electrical continuity guaranteed by copper wires if correctly assembled
- Design Factor 4:1

### Tolerances

According to EN 12115





Refer to Technical Handbook on page TH35

### Temperature Range

-25 °C (-13 °F) to +80 °C (+176 °F)

up to +100 °C (+212 °F) for oil

***Bold-Italic printed part numbers are stock products.***

Part Number				Max. Working Pressure					in Stock
	I.D. (mm)	O.D. (mm)		MPa	psi	bar			
IH36522309/40	19	31	1.6	232.0	16	0.60	125	N	
<b><i>IH36522310/40</i></b>	25	37	1.6	232.0	16	0.89	150	Y	
<b><i>IH36522311/40</i></b>	32	44	1.6	232.0	16	1.00	175	Y	
<b><i>IH36522312/40</i></b>	38	51	1.6	232.0	16	1.30	225	Y	
<b><i>IH36522313/40</i></b>	50	66	1.6	232.0	16	2.00	275	Y	
<b><i>IH36522314/40</i></b>	63.5	79	1.6	232.0	16	2.40	300	Y	
IH36522315/40	75	91	1.6	232.0	16	2.80	350	N	
IH36522316/40	100	116	1.2	180.0	12	3.80	450	N	

Hose layline example

**CARBOCORD EN 12115 NBR 1D I.D. - PN .. - BP .. bar Ω - TRbF 131 T2 p.5.5 - Quarter/Year** 



## CHEMIOEL EN 12115

According to EN 12115

*Designed for suction and delivery of mineral oils and fuels with an aromatic content not exceeding 50 %.*

### Hose Construction

**Tube:** Black, smooth, NBR rubber compound, resistant to oil and fuel with an aromatic content not exceeding 50 %

**Reinforcement:** Synthetic textile fabrics, embedded steel wire helix and built-in copper wire to facilitate the electrical connection between the hose and the end couplings

**Cover:** Black, smooth, NBR/SBR rubber compound, antistatic (R < 1 MΩ/m), oil, fuel, abrasion, ageing and weather resistant

### Temperature Range

-25 °C (-13 °F) to +80 °C (+176 °F)  
up to +100 °C (+212 °F) for oil



- Meets TRbF 131 Teil 2 par 5.5 (flame resistance)
- Optimal for tank truck application
- Crimped solution with 48 series and Large Bore series
- Vacuum 0.9 bar for ID up to 63.5 mm then 0.8 bar
- Design Factor 4:1

### Tolerances

According to EN 12115  
Refer to Technical Handbook on page TH35

### Fitting Series

48 (up to I.D. 50 mm)  
IF (from I.D. 63.5 mm)

***Bold-Italic printed part numbers are stock products.***

Part Number	I.D. (mm)	O.D. (mm)	Max. Working Pressure			Weight kg/m	min. Bend Radius mm	in Stock
			MPa	psi	bar			
<b><i>IH36530229/40</i></b>	19	31	1.6	232.0	16	0.70	125	Y
<b><i>IH36530230/40</i></b>	25	37	1.6	232.0	16	0.90	150	Y
<b><i>IH36530231/40</i></b>	32	44	1.6	232.0	16	1.20	175	Y
<b><i>IH36530232/40</i></b>	38	51	1.6	232.0	16	1.50	225	Y
<b><i>IH36530233/40</i></b>	50	66	1.6	232.0	16	2.30	275	Y
<b><i>IH36530234/40</i></b>	63.5	79	1.6	232.0	16	2.80	300	Y
<b><i>IH36530235/40</i></b>	75	91	1.6	232.0	16	3.30	350	Y
<b><i>IH36530236/20</i></b>	100	116	1.2	180.0	12	4.70	450	Y

Hose layline example

**CHEMIOEL EN 12115:2011 - NBR1 - SD - I.D. - WP ...bar - Ω - TRbF 131 T2p. 5.5 - Quarter/Year** 

 Oil & Fuel

## CERVINO EN 12115

According to EN 12115

*Suction and delivery of mineral oils and fuels, with an aromatic content not exceeding 50 %. The special compounds make the hose specially indicated for outdoor applications, when low temperature conditions are implicated.*

### Hose Construction

- Tube:** Black, smooth, NBR rubber compound, resistant to oil and fuel with an aromatic content not exceeding 50 %
- Reinforcement:** Synthetic textile fabrics, embedded steel wire helix and built-in copper wire to facilitate the electrical connection between the hose and the end couplings
- Cover:** Black, smooth, abrasion resistance NBR/SBR rubber compound, antistatic ( $R < 1 \text{ M}\Omega/\text{m}$ ), oil, fuel, low temperature, ageing and weather resistant



- Technology nitrogen tested for safe air applications
- Cold bend tested as per ISO 4672 without cracks
- Good result on cover abrasion test as per ISO 6945
- Crimped solution with 48 series and Large Bore series
- Vacuum 0.8 bar (600 mm Hg)
- Design Factor 4:1

### Temperature Range





-40 °C (-40 °F) to +80 °C (+176 °F)  
up to +100 °C (+212 °F) for oil

### Tolerances

According to EN 12115  
Refer to Technical Handbook on page TH35

### Fitting Series

48 (up to I.D. 50 mm)  
IF (from I.D. 63.5 mm)

Part Number			 Max. Working Pressure			 Weight	 min. Bend Radius	in Stock
	I.D. (mm)	O.D. (mm)	MPa	psi	bar	kg/m	mm	
IH36530430/40	50	66	1.6	232.0	16	2.30	200	N
IH36530431/40	63.5	79	1.6	232.0	16	2.80	250	N
IH36530432/40	75	91	1.6	232.0	16	3.30	300	N
IH36530433/40	100	116	1.2	180.0	12	4.70	400	N

Hose layline example

CERVINO EN 12115-2011 - NBR1 - SD - I.D. - WP ...bar - Ø - TR0F 121 T2p. 5.5 - Quarter/Year



## E-Z FORM™ HT

Parker Global Product

*Extremely flexible, lightweight, high temperature petroleum-based oil suction/return hose designed to resist cracking and deterioration for the extreme heat generated in Tier IV engine. It may also be used in non-SAE power steering applications (as a low pressure return line only). The lightweight Greek corrugated hose construction incorporates a wire helix that provides full suction capability. The unique corrugations are tightly pitched and precision-engineered, providing extreme flexibility compared to the traditional rounded corrugation profile. The cover is resistant to high temperature oil in high temperature environments.*

### Hose Construction

**Tube:** Black CPE  
**Reinforcement:** Multiple textile braids with helix  
**Cover:** Black Hydrogenate NBR, Greek corrugated finish



- Saves time and costs thanks to easy and quick assembly
- Superior kink resistance, minimal force to bend, outstanding flexibility
- In buses, cranes, trucks and mobile/heavy duty off-road equipment
- Design Factor 4:1
- Vacuum: 0,9 bar

### Temperature Range

-40 °C (-40 °F) to +150 °C (+302 °F)





### Tolerances

According to UNI EN ISO 1307  
Refer to Technical Handbook on page TH35

### Fitting Series

48

***Bold-Italic printed part numbers are stock products.***

Part Number				Max. Working Pressure					in Stock
	I.D. (mm)	O.D. (mm)		MPa	psi	bar			
<b><i>7399-0500025</i></b>	12.7	23.8	1.0	150	10	0.43	23	Y	
<b><i>7399-0625025</i></b>	15.9	27.0	1.0	150	10	0.54	33	Y	
<b><i>7399-0750025</i></b>	19.1	30.0	1.0	150	10	0.56	36	Y	
<b><i>7399-0875025</i></b>	22.2	32.8	1.0	150	10	0.61	36	Y	
<b><i>7399-1000025</i></b>	25.4	36.0	1.0	150	10	0.66	36	Y	

coils of 7.62 m (25 feet)

Hose layline example

 SERIES 7399 E-Z FORM HT HOSE (ID) 150 PSI MAX WP MADE IN USA



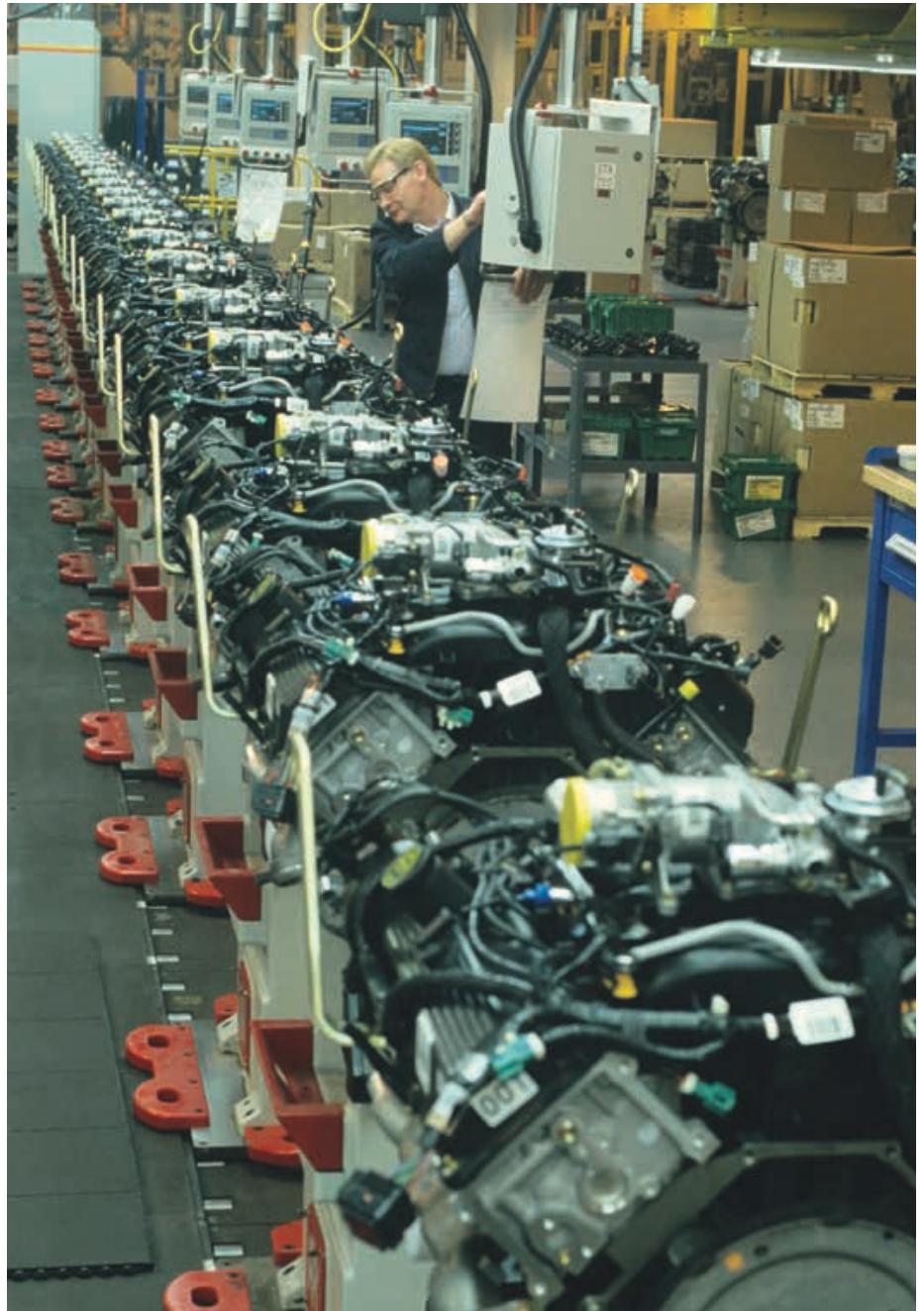

## Automotive & Boat



**Automotive & Boat**

## B – Automotive & Boat

Hose	ID Range (mm)	Temp. Range (°C)	Application
RADIOR 10	7 - 15	-30 / +100	cooling line system
E-Z FORM™ GS	12.7 - 102	-45 / +125	high flexible hose for coolant line system
RADIOR DIN 6	10 - 50	-40 / +125	cooling line system
Series 6722	6 - 25	-54 / +177	Heater and cooling line system
AIRBRAKE DIN 74310	9 - 13	-40 / +70	breaking system
Series 395 SAE J 30R7	4.8 - 12.7	-40 / +125	car & motorbike fuel system
TBSE	4 - 10	-30 / +100	car & motorbike fuel system
TBE	3 - 7.5	-20 / +90	car & motorbike fuel system
CARBOBLUE N/L 10	16 - 25	-40 / +100	nox reducing system
CARBOBLUE N/L 20	6 - 25	-40 / +100	nox reducing system
WAVEMASTER™	6.3 - 19	-29 / +100	marine barrier fuel hose
SM/TR 311	19 - 50	-20 / +80	coolant line
SUPER-FLEX® FL-7	4.7 - 19.1	-40 / +125	low permation fuel hose
SUPER-FLEX® FL	4.7 - 15.9	-30 / +125	low permation fuel hose



	Tube	Reinforce- ment	Cover	WP (bar)	Design Factor	Suction	Industry standard	Page
	EPDM	textile	EPDM	10	3			<b>B4</b>
	EPDM	textile	EPDM	5	4	yes	SAE J 20R2 - D1	<b>B5</b>
	EPDM	textile	EPDM	6	3			<b>B6</b>
	SILICONE	textile	SILICONE	5.7	3		SAE J20R3 Class A	<b>B7</b>
	EPDM	textile	EPDM	10	4		DIN 74310	<b>B8</b>
	NBR	textile	CR	2.4 5.2	5		SAE 30 R7	<b>B9</b>
	NBR	textile	NBR/EPDM	10	3			<b>B10</b>
	NBR	textile		10	3			<b>B11</b>
	EPDM	textile	EPDM	10	3			<b>B12</b>
	EPDM	textile	EPDM	20	3			<b>B12</b>
	NYLON	textile	NBR/PVC	7	4	light	Refer to the page	<b>B13</b>
	NBR	textile	NBR/CR	3	> 3.5	yes	EN ISO 7840 A1	<b>B14</b>
	NBR/THV	textile	CPE	6.9	5	light	SAEJ30R7/J30R14T2	<b>B15</b>
	NBR/ barrier	textile	CPE	6.9	5	light	AEJ30R7/J30R14T2	<b>B16</b>



 Automotive & Boat

## RADIOR 10

*Flexible rubber hose for delivery of hot water in heating and cooling of automotive LPG and methane systems.*

### Hose Construction

**Tube:** Black, smooth EPDM nitrosamine free rubber compound  
**Reinforcement:** Synthetic textile yarns  
**Cover:** Smooth, black, heat, ageing and weather-resistant EPDM nitrosamine free rubber compound

### Temperature Range

-30 °C (-22 °F) to + 100 °C (+212 °F)  
with peaks +120 °C (+248 °F)







- Specific for cooling system
- Robust structure to avoid kinking
- Design Factor 3:1

### Tolerances

According to UNI EN ISO 1307  
Refer to Technical Handbook on page TH35

***Bold-Italic printed part numbers are stock products.***

Part Number			 Max. Working Pressure			 Weight	 min. Bend Radius	in Stock
	I.D. (mm)	O.D. (mm)	MPa	psi	bar	kg/m	mm	
<b><i>IH30114029/100</i></b>	7	13	1.0	150.0	10	0.13	50	Y
<b><i>IH30114030/100</i></b>	15	23	1.0	150.0	10	0.35	90	Y

Hose layline example

RUBBER HOSE RADIOR 10 bar I.D. mm





## E-Z FORM™ GS

*Designed to handle air, coolant, mild chemicals and water. Extremely flexible, lightweight provides full suction capability and a path to conduct a static electrical charge to ground. The unique Greek cover corrugations provides minimal force-to-bend, superior kink resistance, and maximum flexibility for ease of handling, used where formed hose might normally be required.*

### Hose Construction

- Tube:** Black EPDM, antistatic rubber compound
- Reinforcement:** Multiple textile plies with wire helix
- Cover:** Black EPDM rubber compound resistant to weathering, greek corrugated finish

### Temperature Range

-45 °C (-50 °F) to +125 °C (+257 °F)



- Premium grade high temperature EPDM materials
- Saves time and costs thanks to easy and quick assembly
- Superior kink resistance, minimal force to bend, outstanding flexibility
- Performance equal to SAE J20R2-D1
- Design Factor 4:1
- Vacuum: 0.9 bar





### Tolerances

According to UNI EN ISO 1307  
Refer to Technical Handbook on page TH35

### Fitting Series

48 (up to I.D. 51 mm)

***Bold-Italic printed part numbers are stock products.***

Part Number	 I.D. (mm)	 O.D. (mm)	 Max. Working Pressure			 Weight kg/m	 min. Bend Radius mm	in Stock
			MPa	psi	bar			
<b><i>IH73950500/10</i></b>	12.7	23.8	0.5	75	5	0.4	23	Y
<b><i>IH73950625/10</i></b>	15.9	27	0.5	75	5	0.49	33	Y
<b><i>IH73950750/10</i></b>	19.1	30	0.5	75	5	0.52	36	Y
<b><i>IH73951000/10</i></b>	25.4	36	0.5	75	5	0.61	36	Y
<b><i>IH73951125/10</i></b>	29	38	0.5	75	5	0.62	46	Y
<b><i>IH73951250/10</i></b>	32	43	0.5	75	5	0.75	56	Y
<b><i>IH73951375/10</i></b>	35	46	0.5	75	5	0.79	71	Y
<b><i>IH73951500/10</i></b>	38	49	0.5	75	5	0.85	74	Y
<b><i>IH73952000/10</i></b>	51	63	0.5	75	5	1.44	117	Y
<b><i>IH73952250/10</i></b>	57	70	0.5	75	5	1.61	165	Y
<b><i>IH73952375/10</i></b>	60	73	0.5	75	5	1.64	175	Y
<b><i>IH73952500/10</i></b>	63.5	76.5	0.5	75	5	1.74	183	Y
<b><i>IH73953000/10</i></b>	76	90	0.5	75	5	2.23	223	Y
<b><i>IH73954000/10</i></b>	102	116	0.5	75	5	3.28	340	Y

Hose layline example



 Automotive & Boat

## RADIOR DIN 6 (COILS)

*Designed for cooling systems of automotive engines and stationary engines and for refrigerant systems.*

### Hose Construction

- Tube:** Black, smooth, antistatic, heat resistant EPDM rubber compound according to DIN 73411 - 1996\*
- Reinforcement:** Synthetic textile fabrics yarns
- Cover:** Black, smooth, wrapped finish, heat, ageing and weather-resistant EPDM rubber compound according to DIN 73411 - 1996\*

\*The tube and the cover compounds are according to DIN 73411 - 1996 in the following principal areas: tensile, strength, density, hardness, laceration, swellings, aging and dry residue.

### Temperature Range

-40 °C (-40 °F) to +125 °C (+257 °F)  
with peaks to +140 °C (+284 °F)

***Bold-Italic printed part numbers are stock products.***







- Performances fully compliant to DIN73411
- Compounds according to DIN 73411 for: tensile, strength, density, hardness, laceration, swellings, aging and dry residue
- Specific for cooling system at high temperature
- For Automotive and general industries application
- Design Factor 3:1
- Available on request in Cut Length of 1 m

### Tolerances

I.D. ≤ 25 mm  
according to UNI EN ISO 1307

I.D. > 25 mm  
according to RMA steel mandrel  
Refer to Technical Handbook on page TH35

Part Number			 Max. Working Pressure			 Weight	 min. Bend Radius	in Stock
	I.D. (mm)	O.D. (mm)	MPa	psi	bar	kg/m	mm	
<i>IH30836101/40</i>	10	17	0.6	90.0	6.0	0.17	–	Y
<i>IH30836103/40</i>	13	20	0.6	90.0	6.0	0.21	–	Y
<i>IH30836104/40</i>	15	22	0.6	90.0	6.0	0.23	–	Y
<i>IH30836105/40</i>	16	23	0.6	90.0	6.0	0.25	–	Y
<i>IH30836106/40</i>	18	25	0.6	90.0	6.0	0.27	–	Y
<i>IH30836107/40</i>	20	27	0.6	90.0	6.0	0.30	–	Y
<i>IH30836108/40</i>	22	29	0.6	90.0	6.0	0.33	–	Y
<i>IH30836109/40</i>	25	34	0.6	90.0	6.0	0.48	–	Y
<i>IH36836110/40</i>	28	36	0.6	90.0	6.0	0.52	–	Y
<i>IH36836111/40</i>	30	38	0.6	90.0	6.0	0.55	–	Y
<i>IH36836112/40</i>	32	40	0.6	90.0	6.0	0.58	–	Y
<i>IH36836113/40</i>	35	43	0.6	90.0	6.0	0.63	–	Y
<i>IH36836114/40</i>	38	48	0.6	90.0	6.0	0.88	–	Y
<i>IH36836115/40</i>	40	50	0.6	90.0	6.0	0.92	–	Y
<i>IH36836116/40</i>	42	52	0.6	90.0	6.0	0.96	–	Y
<i>IH36836117/40</i>	45	55	0.6	90.0	6.0	1.02	–	N
<i>IH36836119/40</i>	50	60	0.6	90.0	6.0	1.11	–	Y

Hose layline example

**RADIOR DIN - A - I.D. x TH - EPDM / P / EPDM - 6 bar - 125°C**  (yellow ink x LL and yellow embossed x MM) Y/W (with traceability code)



## SERIES 6722

### Parker Global Product

*Extruded heater hose that meets or exceeds SAEJ20R3 Class A specifications. This product is utilized as standard equipment on trucks, cars and buses. Since this product is extruded it can be offered in long lengths, which saves money by reducing scrap. These hoses are resistant to coolant solutions, cracking, ozone, cold leaks, peeling and aging.*

#### Hose Construction

- Tube:** Brick Red Silicone rubber compound, heat and cold resistant
- Reinforcement:** High-temperature-resistant plies
- Cover:** Blue, Silicone rubber resistant to weathering, ozone and cracking

#### Temperature Range

-54 °C (-65 °F) to +177 °C (+350 °F)







- Specific for Heater and Cooling system on cars, trucks and buses
- For Automotive and general industries application
- According to SAE J20R3 Class A and SAE J2387
- Design Factor 3:1

#### Tolerances

According to UNI EN ISO 1307  
Refer to Technical Handbook on page TH35

***Bold-Italic printed part numbers are stock products.***

Part Number	 I.D. (mm)	 O.D. (mm)	 Max. Working Pressure			 Weight kg/m	 min. Bend Radius mm	in Stock
			MPa	psi	bar			
<b><i>6722-0250050</i></b>	6	13	0.57	83	5.7	0.150	13	N
<b><i>6722-0375050</i></b>	10	18	0.57	83	5.7	0.196	19	Y
<b><i>6722-0500050</i></b>	13	21	0.57	83	5.7	0.251	38	Y
<b><i>6722-0625050</i></b>	16	24	0.57	83	5.7	0.357	44	Y
<b><i>6722-0750050</i></b>	19	27	0.46	67	4.6	0.385	70	Y
<b><i>6722-1000050</i></b>	25	34	0.40	58	4.0	0.506	127	Y

coils of 15.24 m (50 feet)

Hose layline example

PARKER SILICONE SERIES 6722 -65 °F to +350 °F [DATE CODE]

 Automotive & Boat

## AIRBRAKE DIN 74310

According to DIN 74310

Parker Global Product

*Widely used in automotive air brake systems.*

### Hose Construction

**Tube:** Black, smooth EPDM nitrosamine free rubber compound

**Reinforcement:** Stress-resistant, synthetic textile yarns

**Cover:** Black, abrasion, ageing and weather-resistant, smooth EPDM nitrosamine free rubber compound

### Temperature Range

-40 °C (-40 °F) to + 70 °C (+158 °F)



- Recommended DIN 74304 and DIN 74325 fittings and DIN 3017 clamps
- Automotive application
- Nitrosamine free compounds
- Design Factor 4:1







### Tolerances

According to DIN 74310

*Refer to Technical Handbook on page TH35*

***Bold-Italic printed part numbers are stock products.***

Part Number			 Max. Working Pressure			 Weight	 min. Bend Radius	in Stock
	I.D. (mm)	O.D. (mm)	MPa	psi	bar	kg/m	mm	
<b><i>IH30315103/40</i></b>	9	16	1.0	150.0	10	0.19	65	Y
<b><i>IH30315116/40</i></b>	11	18	1.0	150.0	10	0.22	70	Y
<b><i>IH30315115/40</i></b>	13	25	1.0	150.0	10	0.49	100	Y

Hose layline example

 I.D. mm DIN 74310 - Year/Quarter with traceability code



## SERIES 395 SAE J30R7

Series 395 is a fuel line/vapor emission hose for refined fuels such as biodiesel (to B20 in dedicated and non-dedicated service), diesel, ethanol and gasoline. The hose is flexible for easy routing in and around small engines and small engine compartments, and the cover is resistant to abrasion, oil and weathering.

### Hose Construction

**Tube:** Black nitrile  
**Reinforcement:** Multiple textile plies  
**Cover:** Black chloroprene; smooth finish

### Temperature Range

-40 °C (-40 °F) to +125 °C (+257 °F)







- Low pressure fuel lines, vapor emission service
- B20, diesel, ethanol, gasoline
- Agricultural equipment, autos, buses, construction equipment, off-road equipment
- Design factor 5:1

### Tolerances

According to SAE J30 R7  
Refer to Technical Handbook on page TH35

***Bold-Italic printed part numbers are stock products.***

Part Number	 I.D. (mm)	 O.D. (mm)	 Max. Working Pressure			 Weight kg/m	 min. Bend Radius mm	in Stock
			MPa	psi	bar			
39553	4.8	10.3	0.52	75	5.2	0.100	50.8	N
<b>39550</b>	6.4	12.7	0.34	50	3.4	0.164	50.8	Y
<b>39551</b>	7.9	14.3	0.34	50	3.4	0.166	76.2	Y
<b>39552</b>	9.5	15.9	0.34	50	3.4	0.200	88.9	Y
<b>39554</b>	12.7	19.8	0.24	35	2.4	0.260	101.6	Y

Supplied in reels of 250 feet each (76.2 m), with max 2 lengths at least 25 feet (7.62 m) long

Hose layline example

(ID) FUEL/VAPOR LINE SAE J30R7 (DATE CODE)

 Automotive & Boat

## TBSE

*Designed for general applications in fuel systems where low permeability levels are required. Suitable for leaded and unleaded fuels and diesel.*

### Hose Construction

- Tube:** Black, oil and fuel resistant, smooth, antistatic ( $R < 1 \text{ M}\Omega/\text{m}$ ), NBR rubber compound
- Reinforcement:** Synthetic textile yarns
- Cover:** Black, oil, fuel, abrasion, weather-resistant, smooth, antistatic ( $R < 1 \text{ M}\Omega/\text{m}$ ), NBR/EPDM rubber compound



- Antistatic cover and tube compounds
- Low permeability
- Suitable for B20 and E100 up to 70 °C
- Available packaging in reels for display stand
- Design Factor 3:1



### Tolerances

According to UNI EN ISO 1307  
Refer to Technical Handbook on page TH35

### Temperature Range

-30 °C (-22 °F) to +100 °C (+212 °F)

***Bold-Italic printed part numbers are stock products.***

Part Number			 Max. Working Pressure			 Weight	 min. Bend Radius	in Stock
	I.D. (mm)	O.D. (mm)	MPa	psi	bar	kg/m	mm	
<b>Coils</b>								
<b><i>IH30871001/100</i></b>	4	9	1.0	150.0	10	0.07	30	Y
<b><i>IH30871011/100</i></b>	5	10	1.0	150.0	10	0.08	40	Y
<b><i>IH30871021/100</i></b>	6	13	1.0	150.0	10	0.14	55	Y
<b><i>IH30871031/100</i></b>	7	13	1.0	150.0	10	0.13	55	Y
<b><i>IH30871041/100</i></b>	7.5	14	1.0	150.0	10	0.15	65	Y
<b><i>IH30871051/100</i></b>	10	16	1.0	150.0	10	0.17	75	Y
<b>Reels</b>								
<b><i>IH30871001/15-R90*</i></b>	4	9	1.0	150.0	10	0.07	30	Y
<b><i>IH30871011/15-R90*</i></b>	5	10	1.0	150.0	10	0.08	40	Y
<b><i>IH30871021/15-R90*</i></b>	6	13	1.0	150.0	10	0.14	55	Y
<b><i>IH30871031/15-R90*</i></b>	7	13	1.0	150.0	10	0.13	55	Y
<b><i>IH30871041/15-R90*</i></b>	7.5	14	1.0	150.0	10	0.15	65	Y
<b><i>IH30871051/10-R60**</i></b>	10	16	1.0	150.0	10	0.17	75	Y

\* box quantity = 6 x 15 m (reels)

\*\* box quantity = 6 x 10 m (reels)

Hose layline example

ORIGINAL ECO 1 TBSE MADE IN ITALY 



## TBE

*Designed for particular applications in fuel systems where textile cover is requested. Suitable for leaded and unleaded fuels and diesel.*

### Hose Construction

**Tube:** Black, oil and fuel resistant, smooth NBR rubber compound

### Reinforcement/ Cover:

High tensile polyester textile over-braid, resistant to abrasion, fuel, oil and weathering

### Temperature Range

-20 °C (-4 °F) to +90 °C (+194 °F)



- Available in reels only
- Suitable for B20 and E100 up to 70 °C
- Designed for motorbike fuel supply
- Design Factor 3:1

### Tolerances

On inside diameter: + 0 / - 0.5 mm  
Length tolerance: ± 1 %

***Bold-Italic printed part numbers are stock products.***

Part Number	I.D. (mm)	O.D. (mm)	Max. Working Pressure			Weight kg/m	min. Bend Radius mm	in Stock
			MPa	psi	bar			
<b><i>IH11001300/15-R90*</i></b>	3	7	1.0	150.0	10	0.04	30	Y
<b><i>IH11001345/15-R90*</i></b>	7.5	14.5	1.0	150.0	10	0.13	65	Y

Hose layline example



 Automotive & Boat

## CARBOBLUE N/L 10 - 20

Parker Global Product

*Carboblue is specially designed for applications where there is a requirement for extracting NOx (nitrogen oxide and its mixtures that emit polluted substances into the environment during air combustion) and dramatically reducing exhaust gas from diesel engines. These objectives are included in European parameters EURO IV and EURO V.*

### Hose Construction

**Tube:** Black, smooth, antistatic (R < 1 MΩ/m) and sulphur free EPDM rubber compound nitrosamine free with peroxide curing.

*Extensive tests on tensile stress, cold bending, heat, and laceration resistance on compound in contact with the additive did not show alteration of its state.*

**Reinforcement:** Synthetic textile fabrics  
**Cover:** Black, smooth, antistatic (R < 1 MΩ/m), EPDM rubber compound nitrosamine free, ageing, heat and weather resistant



- Compatibility approved by Urea (AUS32) manufacturer and third part laboratory approved for ISO 22241
- Environmental friendly
- Nitrosamine free
- Design Factor 3:1



### Temperature Range

-40 °C (-40 °F) +100 °C (+212 °F)  
with peaks up to +120 °C (+248 °C)





### Tolerances

According to UNI EN ISO 1307  
Refer to Technical Handbook on page TH35

### Fitting Series

64 + 47

***Bold-Italic printed part numbers are stock products.***

Part Number			 Max. Working Pressure			 Weight	 min. Bend Radius	in Stock
	I.D. (mm)	O.D. (mm)	MPa	psi	bar	kg/m	mm	
<b>CARBOBLUE N/L 10</b>								
IH30515030/100	16	23	1.0	150.0	10	0.27	100	N
<b><i>IH30515031/80</i></b>	19	27	1.0	150.0	10	0.37	115	Y
IH30515032/50	25	36	1.0	150.0	10	0.68	150	N
<b>CARBOBLUE N/L 20</b>								
<b><i>IH30515043/100</i></b>	6	12	2.0	300.0	20	0.11	40	Y
<b><i>IH30515044/100</i></b>	8	15	2.0	300.0	20	0.16	50	Y
IH30515045/100	10	17	2.0	300.0	20	0.19	60	N
IH30515046/100	13	20	2.0	300.0	20	0.23	80	N
<b><i>IH30515040/80</i></b>	16	26	2.0	300.0	20	0.43	100	Y
IH30515041/80	19	30	2.0	300.0	20	0.56	115	N
IH30515047/50	25	37	2.0	300.0	20	0.76	150	N

Hose layline example

RUBBER HOSE CARBOBLUE W.P. bar





## WAVEMASTER™

Parker Global Product

*Premium low permeation fuel tank feed and vent hose for refined fuels such as biodiesel, alcohol blended fuels, diesel, ethanol and gasoline. Specially designed for marine applications. The hose incorporates a thermoplastic barrier to resist fuel permeation and the cover is resistant to abrasion, oil and weathering.*

### Hose Construction

**Tube:** Translucent Nylon  
**Reinforcement:** Multiple textile plies  
**Cover:** Black nitrile/PVC; smooth finish

### Temperature Range

-29 °C (-20 °F) to +100 °C (+212 °F)

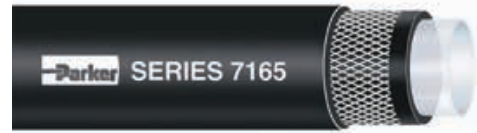

- Meets or exceeds EN ISO 7840:2013 A1, ABYC, CARB, CE, EPA, NMMA, SAE J1527 A1-15, USCG A1
- Flexible for easy routing in engine compartments
- Ideal for feed line to fuel tanks where liquid fuel is continuously in the hose under normal conditions
- Biodiesel up to B100
- Design Factor 4:1
- Vacuum: 0.35 bar

### Tolerances

According to EN ISO 7840  
Refer to Technical Handbook on page TH35

***Bold-Italic printed part numbers are stock products.***

Part Number	I.D. (mm)	O.D. (mm)	Max. Working Pressure			Weight kg/m	min. Bend Radius mm	in Stock
			MPa	psi	bar			
7165-25250	6.3	13.6	0.7	100	7.0	0.16	63.5	N
<b>7165-31250</b>	7.9	15.5	0.7	100	7.0	0.20	63.5	Y
<b>7165-38250</b>	9.5	17.3	0.7	100	7.0	0.23	63.5	Y
<b>7165-50250</b>	12.7	20.9	0.7	100	7.0	0.30	114.3	Y
<b>7165-63250</b>	16.0	25.4	0.52	75	5.2	0.46	114.3	Y
7165-75250	19.0	28.6	0.52	75	5.2	0.51	114.3	N

\*supplied in reels of 76.2 m (250 feet) with max 2 lengths at least 15.24 m (50 feet) long

Hose layline example

**Parker PARKER WAVEMASTER SERIES 7165 MARINE FUEL HOSE - EPA \*PKHPLINE165 - CARB RM-17-006 SAE J1527 USCG TYPE A1-15**

 Automotive & Boat

## SM TR 311

According to EN ISO 7840 A1

*Designed and approved for use in water cooling exhaust gas systems and also as fire resistant fuel hose for craft. Suitable for general loading and unloading oils and fuel service.*

### Hose Construction

- Tube:** Black, smooth, oil and fuel resistant NBR rubber compound
- Reinforcement:** Synthetic textile fabrics, embedded steel wire helix and built-in copper wire to facilitate the electrical connection between the hose and the end couplings
- Cover:** Smooth, black, selfextinguishing NBR/CR rubber compound resistant to heat, oil, abrasion and marine environment. OND version is corrugated.



- Type approval by RINA
- Designed for exhaust gas and refueling
- Suitable for craft according to European Directive 2013-53-EU
- Fire resistant fuel hose
- Design Factor > 3.5:1
- Vacuum 0.8 bar

### Tolerances

According to EN ISO 7840:2013  
Refer to Technical Handbook on page TH35





### Note

Ondulated version on request

### Temperature Range

-20 °C (-4 °F) to +80 °C (+176 °F)

***Bold-Italic printed part numbers are stock products.***

Part Number								in Stock
	I.D. (mm)	O.D. (mm)	MPa	psi	bar	kg/m	mm	
<b><i>IH36971010/40</i></b>	19	29	0.3	43.5	3	0.59	60	Y
<b><i>IH36971011/40</i></b>	25	35	0.3	43.5	3	0.7	75	Y
<b><i>IH36971012/40</i></b>	32	42	0.3	43.5	3	0.84	100	Y
<b><i>IH36971013/40</i></b>	38	48	0.3	43.5	3	1.05	115	Y
<b><i>IH36971014/40</i></b>	45	55	0.3	43.5	3	1.25	145	Y
<b><i>IH36971015/40</i></b>	50	60	0.3	43.5	3	1.65	175	Y

Hose layline example



## SUPER-FLEX® FL-7

Parker Global Product

*Fuel line/vapor emission hose for refined fuels such as biodiesel, diesel, ethanol and gasoline. The hose incorporates a THV barrier to resist permeation, multiple aramid plies of reinforcement for coupling retention, durability and kink resistance, the cover is resistant to abrasion, oil and weathering. The hose is flexible for easy routing in and around small engines and small engine compartments. Permeation value less than 15g/m<sup>2</sup>/day.*

### Hose Construction

- Tube:** Black nitrile and translucent THV barrier, non conductive  
**Reinforcement:** Multiple aramid plies  
**Cover:** Black CPE, smooth finish

### Temperature Range

-40 °C (-40 °F) to +125 °C (+ 257 °F)

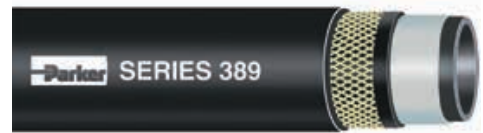

- Meets CARB 2006 SORE, EPA, SAE J30R7, SAE J30R14T2
- for blowers, grinders, mowers, offroad engines, pressure washers, saws, agricultural, buses, construction
- Biodiesel up to B20
- Design Factor 5:1
- Vacuum 0.81 bar for ID up to 9.8 mm then 0.38 bar

### Tolerances

According to UNI EN ISO 1307  
Refer to Technical Handbook on page TH35

***Bold-Italic printed part numbers are stock products.***

Part Number	I.D. (mm)	O.D. (mm)	Max. Working Pressure			Weight kg/m	min. Bend Radius mm	in Stock
			MPa	psi	bar			
<b><i>38903</i></b>	4.8	10.3	0.69	100	6.9	0.10	33.0	Y
<b><i>38904</i></b>	6.4	12.7	0.69	100	6.9	0.13	38.1	Y
<b><i>38905</i></b>	7.9	14.3	0.69	100	6.9	0.16	50.8	Y
<b><i>38906</i></b>	9.8	15.8	0.69	100	6.9	0.16	63.5	Y
<b><i>38908</i></b>	12.7	19.8	0.69	100	6.9	0.26	101.6	Y
38910	15.9	23.9	0.69	100	6.9	0.36	127.0	N
38912	19.1	28.6	0.69	100	6.9	0.52	152.4	N

Supplied in reels of 250 feet each (76.2 m), with max 2 lengths at least 25 feet (7.62 m) long

Hose layline example

**Parker** SERIES 389 SUPER-FLEX® FL-7 (ID) SAE J30R7/R14T2 FUEL LINE (x)PKHPLINE389 EPA COMPLIANT 15 g/m<sup>2</sup>/day CARB Q-08-

 Automotive & Boat

## SUPER-FLEX® FL

Parker Global Product

*Fuel line/vapor emission hose for refined fuels such as diesel, ethanol and gasoline. The hose incorporates a thermoplastic barrier to resist permeation and the cover is resistant to abrasion, oil and weathering. The hose is flexible for easy routing in and around small engines and small engine compartments. Permeation value less than 15g/m<sup>2</sup>/day.*

### Hose Construction

**Tube:** Black nitrile and translucent thermoplastic barrier, non conductive

**Reinforcement:** One textile braid or multiple textile plies

**Cover:** Black CPE, smooth finish

### Temperature Range

-30 °C (-34 °F) to +125 °C (+ 257 °F)

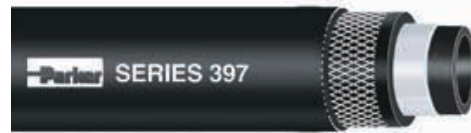





- Meets CARB 2006 SORE, EPA, SAE J30R7/J30R14T2 (Performance)
- for blowers, grinders, mowers, off-road engines, pressure washers, saws, agricultural, autos, buses
- Biodiesel up to B100
- Design Factor 5:1
- Vacuum 0.81 bar for ID up to 9.5 mm then 0.38 bar

### Tolerances

According to UNI EN ISO 1307  
Refer to Technical Handbook on page TH35

***Bold-Italic printed part numbers are stock products.***

Part Number								in Stock
	I.D. (mm)	O.D. (mm)	MPa	psi	bar	kg/m	mm	
<b><i>39703</i></b>	4.7	11.1	0.69	100	6.9	0.10	33.0	Y
<b><i>39704</i></b>	6.4	12.7	0.69	100	6.9	0.13	38.1	Y
<b><i>39705</i></b>	7.9	14.2	0.69	100	6.9	0.16	50.8	Y
<b><i>39706</i></b>	9.5	15.9	0.69	100	6.9	0.16	63.5	Y
<b><i>39708</i></b>	12.7	17.7	0.69	100	6.9	0.26	101.6	Y
39710	15.9	23.9	0.24	35	2.4	0.33	127.0	N

Supplied in reels of 250 feet each (76.2 m), with max 3 lengths at least 25 feet (7.62 m) long

Hose layline example

 **SERIES 397 (P/N) SUPER-FLEX® FL (ID) LOW PERMEATION FUEL LINE CARB (x) PKHPLINE397 EPA COMPLIANT 15 g/m<sup>2</sup>/day**



## Gas





Gas

## C – Gas

Hose	ID Range (mm)	Temp. Range (°C)	Application
AUTOGENE EN ISO 3821 NR/L – NB/L 20	6.3 - 10	-25 / +80	welding process
PROPANPRESS EN ISO 3821 NA/L 20	6.3 - 10	-30 / +70	propan gas delivery
CARBO G NW/L 10 – NB/R 10	8 - 13	-20 / +90	household appliances



	Tube	Reinforce- ment	Cover	WP (bar)	Design Factor	Suction	Industry standard	Page
	EPDM/ SBR	textile	EPDM	20	3		EN ISO 3821	C4
	NBR/NR	textile	EPDM	20	3		EN ISO 3821	C5
	NBR	textile	EPDM	10	3		UNI CIG 7140	C6





Gas

## AUTOGENE EN ISO 3821 NR/L – NB/L 20

According to EN ISO 3821

*Designed for delivery of welding and allied process gases.*

### Hose Construction

**Tube:** Black, smooth EPDM rubber compound resistant to Acetylene gas (Red cover). Black, smooth EPDM/SBR rubber compound resistant to Oxygen gas (Blue cover). Not suitable for LPG, good resistance to ignition (Red and Blue)

**Reinforcement:** Synthetic textile yarns

**Cover:** Smooth, red (NR) or blue (NB) EPDM rubber compound resistant to abrasion, ageing hot surfaces and incandescent particles



- For welding in industrial and domestic application
- Colored cover following specs indication: Red for Acetylene and Blue for Oxygen
- Exceeds the standard on backfire test
- Excellent flexibility
- Design Factor 3:1





### Tolerances

According to EN ISO 3821  
Refer to Technical Handbook on page TH35

### Temperature Range

-25 °C (-13 °F) to +80 °C (+176 °F)

***Bold-Italic printed part numbers are stock products.***

Part Number				Max. Working Pressure					in Stock
	I.D. (mm)	O.D. (mm)		MPa	psi	bar			
<b>AUTOGENE EN ISO 3821 NR/L 20</b>									
<b><i>IH30412803/40</i></b>	6.3	13.3	2.0	300.0	20	0.15	40	Y	
<b><i>IH30412914/100</i></b>	8	15	2.0	300.0	20	0.17	40	Y	
<b><i>IH30412716/40</i></b>	9	16	2.0	300.0	20	0.19	45	Y	
<b><i>IH30412716/100</i></b>	9	16	2.0	300.0	20	0.19	45	Y	
<b><i>IH30413221/40</i></b>	10	17	2.0	300.0	20	0.20	50	Y	
<b><i>IH30413221/100</i></b>	10	17	2.0	300.0	20	0.20	50	Y	
<b>AUTOGENE EN ISO 3821 NB/L 20</b>									
<b><i>IH30412703/40</i></b>	6.3	13.3	2.0	300.0	20	0.15	40	Y	
<b><i>IH30412915/100</i></b>	8	15	2.0	300.0	20	0.17	40	Y	
<b><i>IH30412707/40</i></b>	9	16	2.0	300.0	20	0.22	50	Y	
<b><i>IH30412707/100</i></b>	9	16	2.0	300.0	20	0.22	50	Y	
<b><i>IH30413220/40</i></b>	10	17	2.0	300.0	20	0.24	50	Y	

### IMPORTANT!

Welding applications can be hazardous. Please take all the necessary safety precautions.

Hose layline example

<b>RUBBER HOSE – EN ISO 3821 – 2 MPa (20 bar) – I.D. (Year with traceability code)</b>		<b>MCXX</b>
<b>RUBBER HOSE – EN ISO 3821 – 2 MPa (20 bar) – I.D. (Year with traceability code)</b>		<b>MCXX</b>



## PROPANPRESS EN ISO 3821 NA/L 20

According to EN ISO 3821

*Suitable for LPG in industrial applications.*

### Hose Construction

- Tube:** Black, LPG resistant smooth NBR/  
NR rubber compound
- Reinforcement:** Synthetic textile yarns
- Cover:** Orange, smooth EPDM rubber  
compound resistant to ageing and  
weathering, pin-pricked cover to  
prevent blisters during use



- Orange cover following specs indication
- Flexible hose for easy handling
- Design Factor 3:1

### Temperature Range

-30 °C (-22 °F) to +70 °C (+158 °F)

### Tolerances

According to EN ISO 3821  
*Refer to Technical Handbook on page TH35*

***Bold-Italic printed part numbers are stock products.***

Part Number	I.D. (mm)	O.D. (mm)	Max. Working Pressure			Weight kg/m	min. Bend Radius mm	in Stock
			MPa	psi	bar			
<b><i>IH30413456/100</i></b>	6.3	13.3	2.0	300.0	20	0.16	50	Y
<b><i>IH30413457/100</i></b>	8	15	2.0	300.0	20	0.18	65	Y
<b><i>IH30413459/100</i></b>	8.5	16	2.0	300.0	20	0.21	70	Y
<b><i>IH30413458/100</i></b>	10	17	2.0	300.0	20	0.22	80	Y

Hose layline example



Gas

## CARBO G NW/L 10 – NB/R 10

According to UNI 7140

Connection of household appliances to the gas line (NW/L) or to LPG bottles (NB/R).

### Hose Construction

**Tube:** Black, smooth NBR rubber compound, suitable for Domestic Gas  
**Reinforcement:** Synthetic textile yarns  
**Cover:** White (NW) or blue (NB), ageing-resistant, smooth (/L) or ribbed (/R) EPDM rubber compound

### Temperature Range

-20 °C (-4 °F) to +90 °C (+194 °F)







- Quarterly tested by IMQ (Italian Institute of Quality Approval)
- Low permeability
- Superior tensile strength
- White smooth cover for indoor and blue ribbed cover for outdoor
- Design Factor 3:1

### Tolerances

According to UNI 7140

Refer to Technical Handbook on page TH35

***Bold-Italic printed part numbers are stock products.***

Part Number			 Max. Working Pressure			 Weight	 min. Bend Radius	in Stock
	I.D. (mm)	O.D. (mm)	MPa	psi	bar	kg/m	mm	
CARBO G NB/R 10								
<b><i>IH30551594/100</i></b>	8	13	1.0	150.0	10	0.145	45	Y
CARBO G NW/L 10								
<b><i>IH30551600/100</i></b>	13	20	1.0	150.0	10	0.310	70	Y

Hose layline example

**CARBO/G UNI 7140 – CL1 – TIPO A1 – DN16 – 0,2 bar – IMQ – da sostituire entro il 2019**  **MCXX**

**CARBO/G UNI 7140 – CL1 – TIPO A1 – DN8 – 0,2 bar – IMQ – da sostituire entro il 2019**  **MCXX**

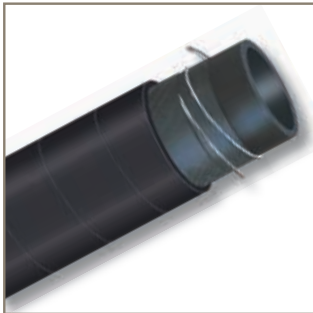

**Water**

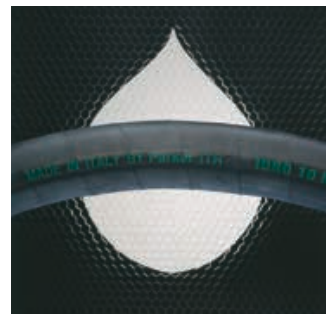



## D – Water

Hose	ID Range (mm)	Temp. Range (°C)	Application
FUCINO 20	50 - 120	-30 / +80	water, non aggressive liquids
PRESCORD N/R 10	8 - 25	-30 / +80	water, non aggressive liquids
IDRO 10	25 - 75	-30 / +80	water, non aggressive liquids
BEVERA 10	19 - 203	-30 / +80	water, non aggressive liquids
MULTIREX	19 - 150	-10 / +60	water, non aggressive liquids

Water



	Tube	Reinforce- ment	Cover	WP (bar)	Design Factor	Suction	Industry standard	Page
	SBR	textile	SBR	20	3			D4
	SBR	textile	SBR/EPDM	10	3			D5
	SBR	textile	SBR	10	3			D6
	SBR	textile	SBR	10	3	yes		D7
	PVC	PVC wire	PVC	7	3	yes		D8

D – Water



## FUCINO 20

*Suitable for a variety of industrial applications, where a flexible and lightweight discharge hose for water and non-aggressive liquids are required. Specifically designed for irrigation equipment and submersible pumps.*

### Hose Construction

**Tube:** Black, smooth SBR nitrosamine free rubber compound  
**Reinforcement:** Synthetic textile fabrics  
**Cover:** Black, abrasion, ageing and weather-resistant SBR nitrosamine free rubber compound

### Temperature Range

-30 °C (-22 °F) to +80 °C (+176 °F)







- Can be rolled flat for easy transport and storage
- Resistant to Ozone and weathering
- Available in two different pressure rates
- Nitrosamine free 
- Design Factor 3:1

### Tolerances

According to RMA steel mandrel  
Refer to Technical Handbook on page TH35

***Bold-Italic printed part numbers are stock products.***

Part Number								in Stock
	I.D. (mm)	O.D. (mm)	MPa	psi	bar			
IH36203276/40	50	58	2.0	300.0	20	0.94	–	N
<b><i>IH36203278/40</i></b>	60	68	2.0	300.0	20	1.10	–	Y
IH36203280/20	80	91	2.0	300.0	20	2.05	–	N
<b><i>IH36203282/20</i></b>	100	113	2.0	300.0	20	2.97	–	Y
<b><i>IH36203283/20</i></b>	120	133	2.0	300.0	20	3.52	–	Y

Hose layline example

RUBBER WATER HOSE FUCINO W.P. bar





## PRESCORD N/R 10

*Suitable for discharge of water and non-aggressive liquids in many industrial and agricultural applications.*

### Hose Construction

**Tube:** Black, smooth SBR nitrosamine free rubber compound  
**Reinforcement:** Synthetic textile yarns  
**Cover:** Black (N), ribbed (/R), abrasion, ageing and weather-resistant, SBR/EPDM nitrosamine free rubber compound



- Resistant to Ozone and weathering
- Nitrosamine free
- Ribbed cover for better flexibility and grip
- Design Factor 3:1



### Temperature Range

-30 °C (-22 °F) to +80 °C (+176 °F)

### Tolerances

According to UNI EN ISO 1307  
Refer to Technical Handbook on page TH35

***Bold-Italic printed part numbers are stock products.***

Part Number	I.D. (mm)	O.D. (mm)	Max. Working Pressure			Weight kg/m	min. Bend Radius mm	in Stock
			MPa	psi	bar			
IH30116062/100	8	15	1.0	150.0	10	0.19	50	N
IH30116063/100	10	17	1.0	150.0	10	0.22	60	N
<b><i>IH30112103/100</i></b>	12	19	1.0	150.0	10	0.26	70	Y
<b><i>IH30112139/100</i></b>	15	21	1.0	150.0	10	0.25	90	Y
<b><i>IH30112136/50</i></b>	18	26	1.0	150.0	10	0.42	110	Y
<b><i>IH30112138/50</i></b>	20	30	1.0	150.0	10	0.59	120	Y
<b><i>IH30112134/50</i></b>	25	35	1.0	150.0	10	0.71	150	Y

Hose layline example

RUBBER HOSE PRESCORD W.P. bar







## IDRO 10

*Suitable for discharge of water and non-aggressive liquids, for agricultural uses, also in industrial facilities and on building sites.*

### Hose Construction

**Tube:** Black, smooth SBR nitrosamine free rubber compound

**Reinforcement:** Synthetic textile fabrics

**Cover:** Black: abrasion, ageing and weather-resistant SBR nitrosamine free rubber compound



- Robust construction
- Resistant to twisting
- Nitrosamine free
- Design Factor 3:1



### Temperature Range

-30 °C (-22 °F) to +80 °C (+176 °F)

### Tolerances

According to RMA steel mandrel  
Refer to Technical Handbook on page TH35

***Bold-Italic printed part numbers are stock products.***

Part Number	I.D. (mm)	O.D. (mm)	Max. Working Pressure			Weight kg/m	min. Bend Radius mm	in Stock
			MPa	psi	bar			
<b><i>IH36203000/40</i></b>	25	34	1.0	150.0	10	0.63	250	Y
<b><i>IH36203002/40</i></b>	30	41	1.0	150.0	10	0.92	300	Y
<b><i>IH36203003/40</i></b>	32	44	1.0	150.0	10	1.07	320	Y
<b><i>IH36203004/40</i></b>	35	48	1.0	150.0	10	1.26	350	Y
<b><i>IH36203005/40</i></b>	38	52	1.0	150.0	10	1.46	380	Y
<b><i>IH36203006/40</i></b>	40	54	1.0	150.0	10	1.52	400	Y
IH36203008/40	45	61	1.0	150.0	10	2.00	450	N
<b><i>IH36203010/40</i></b>	50	68	1.0	150.0	10	2.49	500	Y
<b><i>IH36203011/40</i></b>	60	82	1.0	150.0	10	3.63	600	Y
IH36203103/20	75	91	1.0	150.0	10	2.95	750	N

Hose layline example

RUBBER WATER HOSE IDRO 10 bar





## BEVERA 10

*Suction and delivery of water and non-aggressive liquids. It is recommended for loading and discharge of storage tanks, tankers, for irrigation and for all applications where a flexible and easy to handle hose is required.*

### Hose Construction

- Tube:** Black, smooth SBR nitrosamine free rubber compound
- Reinforcement:** Synthetic textile fabrics and embedded steel wire helix
- Cover:** Black, abrasion, ageing and weather-resistant SBR nitrosamine free rubber compound

### Temperature Range

-30 °C (-22° F) to +80 °C (+176 °F)



- Robust construction
- Resistant to twisting
- Nitrosamine free 
- Vacuum 0.8 bar (600 mm Hg)
- Suitable for air up to 70 °C
- Design Factor 3:1

### Tolerances

According to RMA steel mandrel  
Refer to Technical Handbook on page TH35

### Fitting Series

48 (up to I.D. 50 mm)  
IF (from I.D. 60 mm)

***Bold-Italic printed part numbers are stock products.***

Part Number	I.D. (mm)	O.D. (mm)	Max. Working Pressure			Weight kg/m	min. Bend Radius mm	in Stock
			MPa	psi	bar			
<b><i>IH36214045/40</i></b>	19	29	1.0	150.0	10	0.67	110	Y
<b><i>IH36214050/40</i></b>	25	35	1.0	150.0	10	0.83	150	Y
IH36214051/40	30	40	1.0	150.0	10	0.95	180	N
<b><i>IH36214052/40</i></b>	32	42	1.0	150.0	10	1.01	190	Y
<b><i>IH36214054/40</i></b>	38	48	1.0	150.0	10	1.16	230	Y
<b><i>IH36214055/40</i></b>	40	50	1.0	150.0	10	1.21	240	Y
<b><i>IH36214058/40</i></b>	50	60	1.0	150.0	10	1.50	300	Y
<b><i>IH36214060/40</i></b>	60	71	1.0	150.0	10	1.94	360	Y
IH36214063/20	70	81.5	1.0	150.0	10	2.59	420	N
<b><i>IH36214064/20</i></b>	75	86.5	1.0	150.0	10	2.75	450	Y
<b><i>IH36214066/20</i></b>	80	92.5	1.0	150.0	10	3.02	480	Y
IH36214067/20	90	103.5	1.0	150.0	10	3.66	540	N
<b><i>IH36214068/20</i></b>	100	114	1.0	150.0	10	3.98	600	Y
IH36214070/20	110	124	1.0	150.0	10	4.34	660	N
IH36214071/20	120	134	1.0	150.0	10	4.73	720	N
<b><i>IH36211010/20</i></b>	125	140	1.0	150.0	10	5.66	750	Y
IH36211050/10	150	170	1.0	150.0	10	7.73	900	N
IH36211032/6	203	225	1.0	150.0	10	15.00	1210	N

Hose layline example





## MULTIREX

For suction and delivery of water for irrigation, liquid fertilisers and general industrial uses.

### Hose Construction

Flexible hose having an off-white, rigid PVC spiral embedded in a transparent green, flexible PVC wall

### Temperature Range

-10 °C (+14 °F) to +60 °C (+140 °F)



- Multipurpose hose
- Very flexible hose
- Vacuum 0.7 bar for ID up to 50 mm then 0.6 bar
- Design Factor 3:1

### Tolerances

Refer to Technical Handbook on page TH35

***Bold-Italic printed part numbers are stock products.***

Part Number	I.D. (mm)	Wall (mm)	Max. Working Pressure			Weight kg/m	min. Bend Radius mm	in Stock
			MPa	psi	bar			
IH35602019/50	19	3.0	0.7	101.5	7	0.20	60	N
<b><i>IH35600025/50</i></b>	25	3.0	0.7	101.5	7	0.29	90	Y
IH35600030/50	30	3.1	0.6	87.0	6	0.35	90	N
<b><i>IH35602032/50</i></b>	32	3.2	0.6	87.0	6	0.37	95	Y
IH35600035/50	35	3.5	0.6	87.0	6	0.43	105	N
<b><i>IH35602038/50</i></b>	38	3.6	0.6	87.0	6	0.49	115	N
IH35600040/50	40	3.7	0.6	87.0	6	0.51	120	N
IH35600045/50	45	4.0	0.5	72.5	5	0.57	135	Y
<b><i>IH35600050/50</i></b>	50	4.0	0.5	72.5	5	0.73	150	Y
<b><i>IH35600060/50</i></b>	60	4.2	0.5	72.5	5	0.96	180	Y
IH35600070/50	70	4.5	0.4	58.0	4	1.23	315	N
<b><i>IH35602075/50</i></b>	75	4.6	0.4	58.0	4	1.47	340	Y
<b><i>IH35600080/50</i></b>	80	4.7	0.4	58.0	4	1.57	360	Y
IH35602090/25	90	4.8	0.4	58.0	4	1.92	415	N
<b><i>IH35600100/25</i></b>	100	5.0	0.4	58.0	4	2.11	450	Y
IH35602110/25	110	5.4	0.4	58.0	4	2.56	500	N
IH35600120/25	120	5.8	0.4	58.0	4	2.69	540	N
IH35600150/25	150	6.5	0.3	43.5	3	3.85	675	N

Hose layline example

MULTIREX DIAM I.D. mm PARKER



## Hot Water & Steam





## E – Hot Water & Steam

Hose	ID Range (mm)	Temp. Range (°C)	Application
RADIOR 3	10 - 100	-40 / +100	cooling line system
RADIOR K 1003	12 - 65	-40 / +100	cooling line system
THERMOPRESS 10	12 - 60	-40 / +100	cooling line and hot water
VIGOR 2 EN ISO 6134 Type 2/A	13 - 51	-40 / +210	steam industrial application
VIGOR 2 NR EN ISO 6134 Type 2/A	13 - 51	-40 / +210	steam industrial application

### WARNING!

Steam hoses gradually decrease in performance during service life. Consequently, they need to be regularly inspected by trained personnel wearing adequate protective overalls, including eye protection.

Cuts and gouges in the hose cover showing the textile reinforcement. Steam leaks. Permanent deformation of hose. Reduction of steam flow. WHEN ONE OF THESE ABNORMALITIES OCCURS, THE HOSE SHOULD BE REMOVED FROM SERVICE AND INSPECTED. If a failure occurs close to the couplings, the damaged hose can be cut, reconnected and used as before.

Use only couplings with safety clamps. Follow the coupling manufacturer's instructions for coupling procedures. Check coupling tightness each time before use. Drain after use. When not in use, store the hose on a flat surface (shelves) and never hang from a hook.

Hot Water & Steam



Tube	Reinforce- ment	Cover	WP (bar)	Design Factor	Suction	Industry standard	Page
EPDM	textile	EPDM	3	3			E4 - E5
NBR	textile	CR	5	3			E6
EPDM	textile	EPDM	10	4			E7
EPDM	textile	EPDM	18	10		ENISO6134Type2/A	E8
EPDM	textile	EPDM	18	10		ENISO6134Type2/A	E8

E – Hot Water & Steam

 Hot Water & Steam

## RADIOR 3 (COIL)

Designed for cooling systems of automotive engines and stationary engines.

### Hose Construction

**Tube:** Black, smooth, heat resistant EPDM nitrosamine free rubber compound  
**Reinforcement:** Synthetic textile yarn fabric  
**Cover:** Black, smooth, heat, ageing and weather-resistant EPDM nitrosamine free rubber compound

### Temperature Range

-40 °C (-40 °F) to peaks of +100 °C (+212 °F)



- Light and flexible hose
- Also suitable as cable protection
- Nitrosamine free
- Design Factor 3:1







### Tolerances

I.D. ≤ 22 mm according to UNI EN ISO 1307

I.D. > 22 mm according to RMA steel mandrel

Refer to Technical Handbook on page TH35

***Bold-Italic printed part numbers are stock products.***

Part Number	 I.D. (mm)	 O.D. (mm)	 Max. Working Pressure			 Weight kg/m	 min. Bend Radius mm	in Stock
			MPa	psi	bar			
<i>IH36830095/40</i>	10	16	0.3	43.5	3	0.16	–	Y
<i>IH36830096/40</i>	12	18	0.3	43.5	3	0.19	–	Y
<i>IH36830097/40</i>	15	21	0.3	43.5	3	0.23	–	Y
<i>IH36830101/40</i>	18	24.5	0.3	43.5	3	0.29	–	Y
<i>IH36830102/40</i>	20	26.5	0.3	43.5	3	0.32	–	Y
<i>IH36830103/40</i>	22	28.5	0.3	43.5	3	0.34	–	Y
<i>IH36830104/40</i>	25	32	0.3	43.5	3	0.39	–	Y
<i>IH36830105/40</i>	28	36	0.3	43.5	3	0.50	–	Y
<i>IH36830106/40</i>	30	38	0.3	43.5	3	0.53	–	Y
<i>IH36830107/40</i>	32	40	0.3	43.5	3	0.55	–	Y
<i>IH36830108/40</i>	35	43	0.3	43.5	3	0.60	–	Y
<i>IH36830109/40</i>	38	47	0.3	43.5	3	0.73	–	Y
<i>IH36830110/40</i>	40	49	0.3	43.5	3	0.77	–	Y
<i>IH36830111/40</i>	42	51	0.3	43.5	3	0.80	–	Y
<i>IH36830112/40</i>	45	54	0.3	43.5	3	0.85	–	Y
<i>IH36831023/40</i>	48	57	0.3	43.5	3	0.91	–	Y
<i>IH36830113/40</i>	50	60	0.3	43.5	3	1.07	–	Y
<i>IH36830114/40</i>	55	65	0.3	43.5	3	1.17	–	Y
<i>IH36830115/40</i>	60	70	0.3	43.5	3	1.26	–	Y
<i>IH36830116/20</i>	65	76	0.3	43.5	3	1.54	–	Y
<i>IH36830117/20</i>	70	81	0.3	43.5	3	1.65	–	Y
<i>IH36831022/20</i>	75	86	0.3	43.5	3	1.75	–	Y
<i>IH36830118/20</i>	80	92	0.3	43.5	3	2.05	–	Y
<i>IH36830119/20</i>	90	102	0.3	43.5	3	2.29	–	Y
<i>IH36830120/20</i>	100	113	0.3	43.5	3	2.63	–	Y

Hose layline example

RUBBER HOSE RADIOR DIAM. I.D. mm





## RADIOR 3 (CUT LENGTH)

Designed for cooling systems of automotive engines and stationary engines.

### Hose Construction

**Tube:** Black, smooth, heat resistant EPDM nitrosamine free rubber compound  
**Reinforcement:** Synthetic textile yarn fabric  
**Cover:** Black, smooth, heat, ageing and weather-resistant EPDM nitrosamine free rubber compound



- Light and flexible hose
- In piece of 1 m length
- Straight piece without snake effect
- Nitrosamine free
- Design Factor 3:1



### Temperature Range

-40 °C (-40 °F) to peaks of +100 °C (+212 °F)

### Tolerances

I.D. ≤ 22 mm according to UNI EN ISO 1307

I.D. > 22 mm according to RMA steel mandrel  
Refer to Technical Handbook on page TH35

***Bold-Italic printed part numbers are stock products.***

Part Number	I.D. (mm)	O.D. (mm)	Max. Working Pressure			Weight kg/m	min. Bend Radius mm	in Stock
			MPa	psi	bar			
<i>IH36830023/1</i>	15	21	0.3	43.5	3	0.23	–	Y
<i>IH36830001/1</i>	18	24.5	0.3	43.5	3	0.29	–	Y
<i>IH36830002/1</i>	20	26.5	0.3	43.5	3	0.32	–	Y
<i>IH36830003/1</i>	22	28.5	0.3	43.5	3	0.34	–	Y
<i>IH36830004/1</i>	25	32	0.3	43.5	3	0.39	–	Y
<i>IH36830005/1</i>	28	36	0.3	43.5	3	0.50	–	Y
<i>IH36830006/1</i>	30	38	0.3	43.5	3	0.53	–	Y
<i>IH36830007/1</i>	32	40	0.3	43.5	3	0.55	–	Y
<i>IH36830008/1</i>	35	43	0.3	43.5	3	0.60	–	Y
<i>IH36830009/1</i>	38	47	0.3	43.5	3	0.73	–	Y
<i>IH36830010/1</i>	40	49	0.3	43.5	3	0.77	–	Y
<i>IH36830011/1</i>	42	51	0.3	43.5	3	0.80	–	Y
<i>IH36830012/1</i>	45	54	0.3	43.5	3	0.85	–	Y
<i>IH36831030/1</i>	48	57	0.3	43.5	3	0.91	–	Y
<i>IH36830013/1</i>	50	60	0.3	43.5	3	1.07	–	Y
<i>IH36830014/1</i>	55	65	0.3	43.5	3	1.17	–	Y
<i>IH36830015/1</i>	60	70	0.3	43.5	3	1.26	–	Y
<i>IH36830016/1</i>	65	76	0.3	43.5	3	1.54	–	Y
<i>IH36830017/1</i>	70	81	0.3	43.5	3	1.65	–	Y
<i>IH36831031/1</i>	75	86	0.3	43.5	3	1.75	–	Y
<i>IH36830018/1</i>	80	92	0.3	43.5	3	2.05	–	Y
<i>IH36830019/1</i>	90	102	0.3	43.5	3	2.29	–	Y
<i>IH36830020/1</i>	100	113	0.3	43.5	3	2.63	–	Y

Hose layline example

RUBBER HOSE RADIOR DIAM. I.D. mm





 Hot Water & Steam

## RADIOR K 1003

*Designed for heating and cooling systems, resistant to ASTM I/II/III oil up to +100 °C (+212 °F) with peaks up to +120 °C (+248 °F) and diesel fuel up to +50 °C (+122 °F).*

### Hose Construction

**Tube:** Black, smooth, heat resistant NBR rubber compound  
**Reinforcement:** Synthetic textile fabrics yarns  
**Cover:** Black, smooth, wrapped finish, heat, ageing and weather-resistant CR rubber compound



- Superior Chloroprene cover compound for oil and fuel resistance
- Also suitable for B100
- Light and flexible hose
- Design Factor 3:1





### Temperature Range

-40 °C (-40 °F) to +100 °C (+212 °F)

### Tolerances

I.D. ≤ 22 mm according to UNI EN ISO 1307  
I.D. > 22 mm according to RMA steel mandrel  
*Refer to Technical Handbook on page TH35*

***Bold-Italic printed part numbers are stock products.***

Part Number			 Max. Working Pressure			 Weight	 min. Bend Radius	in Stock
	I.D. (mm)	O.D. (mm)	MPa	psi	bar	kg/m	mm	
<b><i>IH30831300/40</i></b>	12	19	0.5	72.5	5	0.24	–	Y
<b><i>IH30831302/40</i></b>	15	22	0.5	72.5	5	0.28	–	Y
<b><i>IH30831303/40</i></b>	18	25	0.5	72.5	5	0.33	–	Y
<b><i>IH30831305/40</i></b>	22	29	0.5	72.5	5	0.39	–	Y
<b><i>IH36831300/40</i></b>	25	32	0.5	72.5	5	0.41	–	Y
<b><i>IH36831301/40</i></b>	28	35	0.5	72.5	5	0.45	–	Y
<b><i>IH36831303/40</i></b>	32	39	0.5	72.5	5	0.51	–	N
<b><i>IH36831305/40</i></b>	38	45	0.5	72.5	5	0.59	–	Y
IH36831308/20	45	56	0.5	72.5	5	1.11	–	N
<b><i>IH36831309/20</i></b>	50	61	0.5	72.5	5	1.22	–	Y
IH36831311/20	60	71	0.5	72.5	5	1.43	–	N
IH36831312/20	65	76	0.5	72.5	5	1.54	–	N

Hose layline example

RUBBER HOSE RADIOR OEL P50 II





## THERMOPRESS 10

Suitable for delivery of hot water, non-aggressive hot liquids and steam to a maximum temperature of +120 °C (+248 °F). To connect boilers to air conditioning units and for hot water cleaning systems.

### Hose Construction

- Tube:** Black, smooth, heat resistant, EPDM nitrosamine free rubber compound
- Reinforcement:** Synthetic textile fabrics or yarns
- Cover:** Black, smooth, heat, ageing and weather-resistant EPDM nitrosamine free rubber compound

### Temperature Range

-40 °C (-40 °F) to +100 °C (+212 °F),  
with peaks +120 °C (+248 °F)



- Robust structure
- Wide temperature range
- Nitrosamine free
- Design Factor 4:1



### Tolerances

I.D. ≤ 20 mm according to UNI EN ISO 1307  
I.D. > 20 mm according to RMA steel mandrel  
Refer to Technical Handbook on page TH35

***Bold-Italic printed part numbers are stock products.***

Part Number	I.D. (mm)	O.D. (mm)	Max. Working Pressure			Weight kg/m	min. Bend Radius mm	in Stock
			MPa	psi	bar			
IH36800002/100	12	22.5	1.0	150.0	10	0.38	120	N
<b><i>IH36800003/80</i></b>	15	25.5	1.0	150.0	10	0.44	150	Y
<b><i>IH36800004/80</i></b>	18	28.5	1.0	150.0	10	0.51	180	Y
<b><i>IH36800005/80</i></b>	20	30.5	1.0	150.0	10	0.56	200	Y
<b><i>IH36800006/40</i></b>	25	35	1.0	150.0	10	0.61	250	Y
<b><i>IH36800007/40</i></b>	30	41	1.0	150.0	10	0.79	300	Y
IH36800009/40	40	54	1.0	150.0	10	1.34	400	N
IH36800011/40	50	68	1.0	150.0	10	2.12	500	N
IH36800012/40	60	82	1.0	150.0	10	3.10	600	N

Hose layline example



 Hot Water & Steam

## VIGOR 2 EN ISO 6134 TYPE 2/A

According to EN ISO 6134 type 2/A

*Designed for high pressure saturated steam (max 18 bar at +210 °C = 261 psi at +410 °F). Suitable for loading saturated and superheated steam in cleaning and sterilization applications, petrochemical industry and general steam service applications*

### Hose Construction

- Tube:** Black, smooth, EPDM rubber compound. Heat and saturated steam resistant
- Reinforcement:** High tensile steel cords
- Cover:** Black, smooth, EPDM rubber compound. Heat, abrasion, ozone and weather resistant.  
The cover is pinpricked to prevent blistering and bubbling.

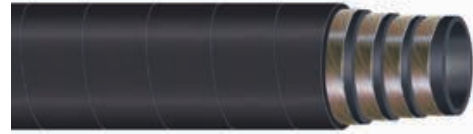

- Wide range temperature
- Pin-pricked cover
- Two cover color lines: black and red
- Working pressure for hot water 45 bar with a Design Factor of 4:1
- Design Factor 10:1





### Tolerances

According to EN ISO 6134  
Refer to Technical Handbook on page TH35

### Temperature Range

-40 °C (-40 °F) to +210 °C (+410 °F)

***Bold-Italic printed part numbers are stock products.***

Part Number			 Max. Working Pressure			 Weight	 min. Bend Radius	in Stock
	I.D. (mm)	O.D. (mm)	MPa	psi	bar	kg/m	mm	
<b>VIGOR 2 EN ISO 6134 (black)</b>								
<b><i>IH36801700/40</i></b>	13	25	1.8	261.0	18	0.50	130	Y
IH36801701/40	16	30	1.8	261.0	18	0.70	160	N
<b><i>IH36801702/40</i></b>	19	33	1.8	261.0	18	0.77	190	Y
<b><i>IH36801703/40</i></b>	25	40	1.8	261.0	18	1.06	250	Y
<b><i>IH36801704/40</i></b>	32	48	1.8	261.0	18	1.39	320	Y
IH36801705/40	38	54	1.8	261.0	18	1.60	380	N
IH36801706/40	51	69	1.8	261.0	18	2.56	500	N
<b>VIGOR 2 EN ISO 6134 (red)</b>								
IH36801720/40	13	25	1.8	261.0	18	0.51	130	N
IH36801721/40	16	29	1.8	261.0	18	0.70	160	N
IH36801722/40	19	33	1.8	261.0	18	0.79	190	N
IH36801723/40	25	40	1.8	261.0	18	1.06	250	N
IH36801724/40	32	48	1.8	261.0	18	1.41	320	N
IH36801725/40	38	54	1.8	261.0	18	1.62	380	N
IH36801726/40	51	69	1.8	261.0	18	2.59	500	N

Hose layline example

**WARNING!** see page E2

**RUBBER HOSE VIGOR - EN ISO 6134:2005 - 2A - steam - 18 bar - 210 °C - I.D. mm - Ø - MADE IN ITALY** 

**RUBBER HOSE VIGOR - EN ISO 6134:2005 - 2A - steam - 18 bar - 210 °C - I.D. mm - Ø - MADE IN ITALY** 

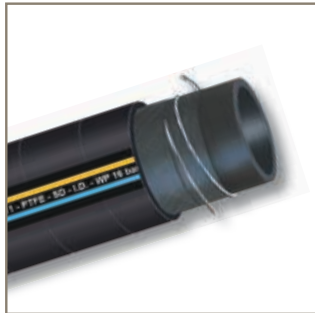

## Acid & Chemicals



 Acid & Chemicals

## F – Acid & Chemicals

Hose	ID Range (mm)	Temp. Range (°C)	Application
POLIAX D EN 12115	19 - 100	-35 / +100	chemical resistance table
POLIAX D SM EN 12115	19 - 100	-35 / +100	chemical resistance table
POLIAX UPE CON SM EN 12115	19 - 100	-20 / +100	chemical resistance table
POLIAX UPE CON SM EN 12115 OND	19 - 100	-20 / +100	chemical resistance table
POLIAX F EN 12115	13 - 75	-40 / +150	chemical resistance table
POLIAX PHARMA	13 - 51	-60 / +200	chemical resistance table

**WARNING!**

If delivering chemicals over +25 °C (+77 °F), please contact us. Many chemical products can cause severe injuries to people or damage to property, and here are risks of environmental pollution in case of leakage or hose burst. All necessary measures must be taken in order to avoid accidents both during normal service operations and during hydrostatic tests, which must be carried out by trained personnel using suitable tools.



Tube	Reinforce- ment	Cover	WP (bar)	Design Factor	Suction	Industry standard	Page
EPM	textile + copper wires	EPDM	16	4		EN 12115	F4
EPM	textile + copper wires	EPDM	16	4	yes	EN 12115	F5
UHMWPE	textile + copper wires	EPDM	16	4	yes	EN 12115	F6
UHMWPE	textile + copper wires	EPDM	16	4	yes	EN12115	F7
PTFE	textile + copper wires	EPDM	16	4	yes	EN 12115	F8
SILICONE	textile + copper wires	SILICONE	6/15	3	yes		F9

 Acid & Chemicals

## POLIAX D EN 12115

According to EN 12115

*Suitable for delivery of highly aggressive chemicals, according to EN 12115,*

### Hose Construction

- Tube:** Black, smooth antistatic EPM nitrosamine free rubber compound
- Reinforcement:** Synthetic textile fabrics and built-in copper wires to facilitate the electrical connection between hose and end couplings
- Cover:** Black, antistatic ( $R < 1 \text{ M}\Omega/\text{m}$ ), EPDM rubber compound, heat, abrasion, ageing and weather resistant

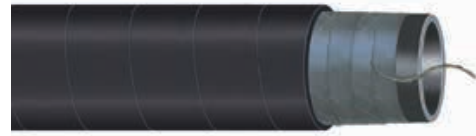

- In-plant and storage tank transfer
- Nitrosamine free
- Suitable for ATEX areas
- Meets TRbF 131 part 2 par 5.5 (flame resistance)
- Design Factor 4:1



### Tolerances

According to EN 12115





Refer to Technical Handbook on page TH35

### Temperature Range

-35 °C (-31 °F) to +100 °C (+212 °F)

For aggressive chemicals and solvents the hose is intended to be used at room temperature. The hose can be cleaned and sterilized with usual detergents or steam – a temperature of +130 °C (+266 °F) for short periods.

***Bold-Italic printed part numbers are stock products.***

Part Number	 I.D. (mm)	 O.D. (mm)	 Max. Working Pressure			 Weight	 min. Bend Radius	in Stock
			MPa	psi	bar			
<b><i>IH36810131/40</i></b>	25	37	1.6	232.0	16	0.71	225	Y
<b><i>IH36810132/40</i></b>	32	44	1.6	232.0	16	0.86	262.5	Y
<b><i>IH36810133/40</i></b>	38	51	1.6	232.0	16	1.11	337.5	Y
<b><i>IH36810134/40</i></b>	50	66	1.6	232.0	16	1.72	412.5	Y
IH36810135/40	63.5	79	1.6	232.0	16	2.10	450	N
IH36810136/40	75	91	1.6	232.0	16	2.56	525	N
IH36810137/40	100	116	1.6	232.0	16	3.38	675	N

### WARNING!

If delivering chemicals over +25 °C (+77 °F), please contact us. Many chemical products can cause severe injuries to people or damage to property, and here are risks of environmental pollution in case of leakage or hose burst. All necessary measures must be taken in order to avoid accidents both during normal service operations and during hydrostatic tests, which must be carried out by trained personnel using suitable tools.

Hose layline example

POLIAX D EN 12115:2011 - EPDM - D - I.D. - WP ...bar - Ω - TRbF 131 T2p. 5.5 - Quarter/Year  **MADE IN ITALY**



## POLIAX D SM EN 12115

According to EN 12115

*Suitable for suction and delivery of highly aggressive chemicals, according to EN 12115.*

### Hose Construction

- Tube:** Black, smooth antistatic EPM nitrosamine free rubber compound
- Reinforcement:** Synthetic textile fabrics, embedded steel wire helix and built-in copper wires to facilitate the electrical connection between hose and end couplings
- Cover:** Black, antistatic ( $R < 1 \text{ M}\Omega/\text{m}$ ), EPDM rubber compound, heat, abrasion, ageing and weather resistant



- In-plant and storage tank transfer
- Nitrosamine free
- Flexibility and kink resistance
- Suitable for ATEX areas
- Meets TRbF 131 part 2 par 5.5 (flame resistance)
- Vacuum 0.9 bar up to 63.5 mm then 0.8 bar
- Design Factor 4:1



### Tolerances

According to EN 12115  
Refer to Technical Handbook on page TH35

### Fitting Series

48 (up to I.D. 50 mm)  
IF (from I.D. 63.5 mm)

### Temperature Range

-35 °C (-31 °F) to +100 °C (+212 °F)

For aggressive chemicals and solvents the hose is intended to be used at room temperature. The hose can be cleaned and sterilized with usual detergents or steam – a temperature of +130 °C (+266 °F) for short periods.

***Bold-Italic printed part numbers are stock products.***

Part Number	I.D. (mm)	O.D. (mm)	Max. Working Pressure			Weight kg/m	min. Bend Radius mm	in Stock
			MPa	psi	bar			
<b><i>IH36810111/40</i></b>	19	31	1.6	232.0	16	0.70	125	Y
<b><i>IH36810112/40</i></b>	25	37	1.6	232.0	16	0.92	150	Y
<b><i>IH36810113/40</i></b>	32	44	1.6	232.0	16	1.09	175	Y
<b><i>IH36810114/40</i></b>	38	51	1.6	232.0	16	1.35	225	Y
<b><i>IH36810115/40</i></b>	50	66	1.6	232.0	16	1.84	275	Y
<b><i>IH36810116/40</i></b>	63.5	79	1.6	232.0	16	2.54	300	Y
<b><i>IH36810117/40</i></b>	75	91	1.6	232.0	16	3.12	350	Y
<b><i>IH36810118/40</i></b>	100	116	1.6	232.0	16	4.41	450	N

### WARNING!

If delivering chemicals over +25 °C (+77 °F), please contact us. Many chemical products can cause severe injuries to people or damage to property, and here are risks of environmental pollution in case of leakage or hose burst. All necessary measures must be taken in order to avoid accidents both during normal service operations and during hydrostatic tests, which must be carried out by trained personnel using suitable tools.

Hose layline example

**POLIAX D EN 12115:2011 - EPDM - SD - I.D. - WP ...bar - Ω - TRbF 131 T2p. 5.5 - Quarter/Year**  **MADE IN ITALY**



 Acid & Chemicals

## POLIAX UPE CON SM EN 12115

According to EN 12115

*POLIAX UPE CON SM EN 12115 is an heavy duty hose for suction and delivery of a wide range of highly aggressive chemicals such as most industrial acids, alkalis, oils, fuels and solvents. It can be used as a flexible connection in paint plants.*

*Refer to the Chemical Resistant Chart to determine compatibility with specific chemicals. For severe or special applications – for tighter bending radius – or if in doubt, please ask our Technical Assistance.*

### Hose Construction

- Tube:** Lucent, black, smooth, conductive, ultra high molecular weight polyethylene (UHMWPE), suitable for foodstuff contact according to FDA, EEC Directive, Italian Decrees
- Reinforcement:** Synthetic textile fabrics, embedded steel wire helix and built-in copper wires to allow the electrical connection between hose and couplings
- Cover:** Black, antistatic ( $R < 1 \text{ M}\Omega/\text{m}$ ), EPDM rubber compound, heat, abrasion, ageing and weather resistant



- High flexibility and kink resistance
- Fits also foodstuffs according to FDA
- Suitable for ATEX areas
- Meets TRbF 131 part 2 par 5.5 (flame resistance)
- Vacuum: 0.9 bar up to dn 63.5, 0.8 bar for larger sizes
- Design Factor 4:1

### Temperature Range

-20 °C (+5 °F) to +100 °C (+212 °F)

*For aggressive chemicals and solvents the hose is intended to be used at room temperature. The hose can be cleaned and sterilized with usual detergents or steam – a temperature of +130 °C (+266 °F) for short periods.*

### Tolerances

According to EN 12115





*Refer to Technical Handbook on page TH35*

### Fitting Series

48 (up to I.D. 50 mm)

IF (from I.D. 63.5 mm)

***Bold-Italic printed part numbers are stock products.***

Part Number				Max. Working Pressure					in Stock
	I.D. (mm)	O.D. (mm)		MPa	psi	bar			
<b><i>IH36811529/40</i></b>	19	31	1.6	232.0	16	0.71	187.5	Y	
<b><i>IH36811530/40</i></b>	25	37	1.6	232.0	16	0.87	225.0	Y	
<b><i>IH36811531/40</i></b>	32	44	1.6	232.0	16	1.07	262.5	Y	
<b><i>IH36811532/40</i></b>	38	51	1.6	232.0	16	1.35	337.5	Y	
<b><i>IH36811534/40</i></b>	50	66	1.6	232.0	16	2.29	412.5	Y	
<b><i>IH36811535/40</i></b>	63.5	79	1.6	232.0	16	2.51	450.0	Y	
<b><i>IH36811536/40</i></b>	75	91	1.6	232.0	16	3.07	525.0	Y	
<b><i>IH36811538/20</i></b>	100	116	1.6	232.0	16	4.43	675.0	N	

### WARNING!

If delivering chemicals over +25 °C (+77 °F), please contact us. Many chemical products can cause severe injuries to people or damage to property, and here are risks of environmental pollution in case of leakage or hose burst.

All necessary measures must be taken in order to avoid accidents both during normal service operations and during hydrostatic tests, which must be carried out by trained personnel using suitable tools.

Hose layline example



## POLIAX UPE CON SM OND EN 12115

According to EN 12115

*POLIAX UPE CON SM EN 12115 OND is a very flexible hose suitable for suction and delivery of a wide range of highly aggressive chemicals such as most industrial acids, alkalis, oils, fuels and solvents. It can also be used as a flexible connections in paint plants.*

*Refer to the Chemical Resistant Chart to determine compatibility with specific chemicals. For severe or special applications – for tighter bending radius – or if in doubt, please ask our Technical Assistance.*

### Hose Construction

- Tube:** Lucent, black, smooth, conductive, ultra high molecular weight polyethylene (UHMWPE), suitable for foodstuff contact according to FDA, EEC Directive, Italian Decrees
- Reinforcement:** Synthetic textile fabrics, embedded steel wire helix and built-in copper wires to allow the electrical connection between hose and couplings
- Cover:** Black, corrugated, antistatic (R < 1 MΩ/m), EPDM rubber compound, heat, abrasion, ageing and weather resistant



- Extreme flexibility, superior kink resistance, minimal force to bend
- Fits also foodstuffs according to FDA
- Suitable for ATEX areas
- Meets TRbF 131 part 2 par 5.5 (flame resistance)
- Vacuum: 0.9 bar up to dn 63.5, for larger sizes 0.8 bar
- Design Factor 4:1

### Temperature Range

-20 °C (+5 °F) to +100 °C (+212 °F)

*For aggressive chemicals and solvents the hose is intended to be used at room temperature. The hose can be cleaned and sterilized with usual detergents or steam – a temperature of +130 °C (+266 °F) for short periods.*

### Tolerances

According to EN 12115

*Refer to Technical Handbook on page TH35*

**Bold-Italic printed part numbers are stock products.**

Part Number	I.D. (mm)	O.D. (mm)	Max. Working Pressure			Weight kg/m	min. Bend Radius mm	in Stock
			MPa	psi	bar			
<b><i>IH36811570/40</i></b>	19	31	1.6	232.0	16	0.71	38	Y
<b><i>IH36811571/40</i></b>	25	37	1.6	232.0	16	0.87	50	Y
<b><i>IH36811572/40</i></b>	32	44	1.6	232.0	16	1.07	64	Y
<b><i>IH36811573/40</i></b>	38	51	1.6	232.0	16	1.35	76	Y
<b><i>IH36811574/40</i></b>	50	66	1.6	232.0	16	2.29	100	Y
IH36811575/40	63.5	79	1.6	232.0	16	2.51	127	N
<b><i>IH36811576/40</i></b>	75	91	1.6	232.0	16	3.07	150	Y
IH36811577/20	100	116	1.6	232.0	16	4.43	200	N

### WARNING!

If delivering chemicals over +25 °C (+77 °F), please contact us. Many chemical products can cause severe injuries to people or damage to property, and here are risks of environmental pollution in case of leakage or hose burst.

All necessary measures must be taken in order to avoid accidents both during normal service operations and during hydrostatic tests, which must be carried out by trained personnel using suitable tools.

Hose layline example

POLIAX EN 12115:2011 - UPE - SD - I.D. - WP ...bar - Ω - TRbF 131 T2p. 5.5 - Quarter/Year  MADE IN ITALY

 Acid & Chemicals

## POLIAX F EN 12115

According to EN 12115

*POLIAX F EN 12115 is manufactured with high quality elastomers, with excellent chemical and mechanical properties, it results suitable for suction and delivery of a wide range of highly aggressive chemicals and solvents. Hose resistant to high temperature and designed for heavy chemical, foodstuff, pharmaceutical and cosmetic industry. Full conductive hose type  $\Omega/T$  according to EN 12115,  $R < 1M\Omega$  and  $R < 1G\Omega$  through the wall. Suitable also for ATEX area.*

*Not to be used with chlorine tri-fluoride, chlorine and fluorine gas, oxygen di-fluoride, phosgene and molten alkalis (e.g., sodium).*

### Hose Construction

**Tube:** Black, smooth, phthalates free PTFE (polytetrafluoroethylene). Superior resistance to high temperature, mechanical stress and to oxidation.

**Reinforcement:** High temperature resistant plies, galvanized helix wire and copper wires to discharge electricity.

**Cover:** Black, smooth, conducting ( $R < 1 M \Omega/m$ ) EPDM rubber compound, ageing, ozone and abrasion resistant.

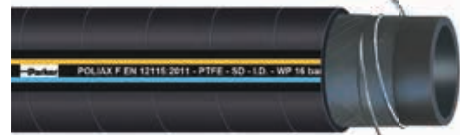

- High flexibility and kink resistance
- Fits also foodstuffs according to FDA
- Suitable for ATEX areas
- Meets TRbF 131 part 2 par 5.5 (flame resistance)
- Meets USP XXXII class VI requirements
- Vacuum: 0.9 bar
- Design Factor 4:1

### Temperature Range

-40 °C (-40 °F) to +150 °C (+302 °F)

*For aggressive chemical and solvents intended to be used at high temperature please contact our Technical Assistance. For cleaning & sterilization refer to "Guidelines to the Use and Cleaning of Food and Pharma rubber hoses".*

### Tolerances

According to EN 12115

Refer to Technical Handbook on page TH35

Part Number	I.D. (mm)	O.D. (mm)	Max. Working Pressure			Weight kg/m	min. Bend Radius mm	in Stock
			MPa	psi	bar			
IH36811541/40	13	25	1.6	232	16	0.54	90	N
IH36811542/40	19	31	1.6	232	16	0.70	130	N
IH36811543/40	25	37	1.6	232	16	0.86	170	N
IH36811544/40	32	44	1.6	232	16	1.18	215	N
IH36811545/40	38	51	1.6	232	16	1.43	255	N
IH36811546/40	50	66	1.6	232	16	2.08	330	N
IH36811547/40	63.5	79.5	1.6	232	16	2.96	430	N
IH36811548/40	75	91	1.6	232	16	3.43	510	N

### WARNING!

If delivering chemicals over +25 °C (+77 °F), please contact us. Many chemical products can cause severe injuries to people or damage to property, and here are risks of environmental pollution in case of leakage or hose burst. All necessary measures must be taken in order to avoid accidents both during normal service operations and during hydrostatic tests, which must be carried out by trained personnel using suitable tools.

Hose layline example

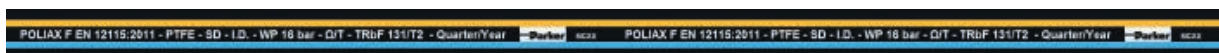



## POLIAX PHARMA

*Flexible hose suitable for suction and delivery of pharmaceutical and cosmetic products and also suitable for food transfer. Not intended for use as an implant material. This silicone hose shows a Platinum-catalyzed cure system.*

*Not suitable for blood or human fluids.*

### Hose Construction

- Tube:** Translucent, smooth, phthalates free, SILICONE rubber compound.
- Reinforcement:** High temperature resistant plies and stainless steel wire helix
- Cover:** Translucent, smooth, SILICONE rubber compound, heat, ageing, ozone and abrasion resistant.

### Temperature Range

-60 °C (-76 °F) to +200 °C (+392 °F)

*For aggressive chemicals and solvents intended to be used at high temperature please contact our Technical Assistance. For cleaning & sterilization refer to "Guidelines to the Use and Cleaning of Food and Pharma rubber hoses"*

### Tolerances

According to UNI EN ISO 1307



- High Flexibility and kink resistance
- Meets European Pharmacopoeia 3.1.9 Ed. VII 2011
- 3A Sanitary Standard Class II
- Japan Ministry of Health and Welfare Notice No.370,1959, No.201,2006 and revision 2012
- USP XXXII class VI requirements
- ISO 10993 Sections 5, 10, 11:2009
- FDA CFR 21 PART 177.2600
- DM 21/03/1973
- BfR Recommendation XV & XXI Cat. 2
- European Regulation 1935/2004/CE
- Tested in compliance with 907/2006/CE (REACH)
- Vacuum: 0.9 bar
- Design Factor 3:1

Part Number	I.D. (mm)	O.D. (mm)	Max. Working Pressure			Weight kg/m	min. Bend Radius mm	in Stock
			MPa	psi	bar			
IH36811580/40	13	24	1.5	225	15	0.46	60	N
IH36811581/40	16	27	1.4	210	14	0.53	70	N
IH36811582/40	19	30	1.3	195	13	0.6	80	N
IH36811583/40	25	36	1.0	150	10	0.73	100	N
IH36811584/40	32	43	0.8	120	8	0.89	130	N
IH36811585/40	38	51	0.7	105	7	1.21	155	N
IH36811586/40	51	64	0.6	90	6	1.56	210	N

### WARNING!

If delivering chemicals over +25 °C (+77 °F), please contact us. Many chemical products can cause severe injuries to people or damage to property, and here are risks of environmental pollution in case of leakage or hose burst. All necessary measures must be taken in order to avoid accidents both during normal service operations and during hydrostatic tests, which must be carried out by trained personnel using suitable tools.

Hose layline example

→POLIAX →PHARMA →Parker



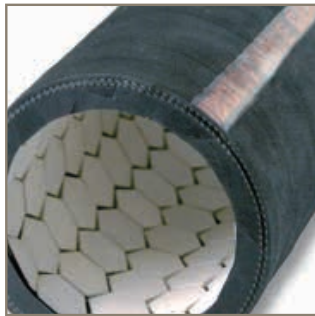

## Material Handling



 Material Handling

## G – Material Handling

Hose	ID Range (mm)	Temp. Range (°C)	Application
LIBECCIO EN ISO 3861	19 - 100	-30 / +70	wet and dry sand and cement
INTONACATRICI 40	25 - 65	-30 / +70	wet and dry sand and cement
BETON 80	51 - 125	-40 / +70	high pressure concrete pumping
CERGOM	25 - 200	-30 / +70	high abrasive materials
ASPIREX	20 - 250	-15 / +60	suction equipment

Material Handling



Tube	Reinforcement	Cover	WP (bar)	Design Factor	Suction	Industry standard	Page
BR/NR	textile	SBR/NBR	10	4		EN ISO 3861	G4
BR/NR	textile	SBR	40	3			G5
NR/SBR	steel wire	NR/SBR	80	2.5			G6
CERAMIC	textile + copper wires	SBR/NBR	6	3	yes		G7
PVC	PVC wire	PVC	-	-	yes		G8



 **Material Handling**

## LIBECCIO EN ISO 3861

According to EN ISO 3861

*Suitable for conveying of wet and dry sand and grit blasting materials.*

### Hose Construction

**Tube:** Smooth, black, antistatic, abrasion resistant BR/NR rubber compound. Abrasion according to ISO 4649: max. 60 - 70 mm<sup>3</sup>

**Reinforcement:** Synthetic textile fabrics

**Cover:** Black, smooth, antistatic, weather and abrasion resistant SBR/NBR compound. The cover is pinpricked to prevent blistering and bubbling, max. resistance on finished hose: 2,0 MΩ/m



- Exceeds EN ISO 3861 requirements
- Robust and light version available
- Construction, general industry, shipyards
- Design Factor 4:1





### Tolerances

According to RMA steel mandrel  
*Refer to Technical Handbook on page TH35*

### Temperature Range

-30 °C (-22 °F) to +70 °C (+158 °F)

***Bold-Italic printed part numbers are stock products.***

Part Number								in Stock
	I.D. (mm)	O.D. (mm)	MPa	psi	bar			
<b><i>IH36820300/40</i></b>	19	33	1.0	150.0	10	0.69	190	Y
<b><i>IH36820200/40</i></b>	25	40	1.0	150.0	10	0.92	250	Y
<b><i>IH36820201/40</i></b>	30	45	1.0	150.0	10	1.05	300	Y
<b><i>IH36820202/40</i></b>	32	48	1.0	150.0	10	1.37	320	Y
<b><i>IH36820303/40</i></b>	38	55	1.0	150.0	10	1.46	380	Y
<b><i>IH36820305/40</i></b>	42	60	1.0	150.0	10	1.70	420	N
<b><i>IH36820206/40</i></b>	50	72	1.0	150.0	10	2.54	500	Y
<b><i>IH36820207/40</i></b>	60	82	1.0	150.0	10	2.95	600	Y
<b><i>IH36820209/20</i></b>	80	105	1.0	150.0	10	4.32	800	Y
<b><i>IH36820210/20</i></b>	90	115	1.0	150.0	10	4.84	900	N
<b><i>IH36820211/20</i></b>	100	125	1.0	150.0	10	5.30	1000	N

Hose layline example

**RUBBER HOSE LIBECCIO EN ISO 3861 ID mm – WP 1,0 MPa – BP 4,0 MPa ABRASION 60/70 mm<sup>3</sup>**





## INTONACATRICI 40

*Designed for delivery of plaster and abrasive materials such as mortar and wet cement from plastering machines or spray nozzles.*

### Hose Construction

**Tube:** Black, abrasion resistant, antistatic smooth BR/NR rubber compound.  
Abrasion max. 60 - 70 mm<sup>3</sup>

**Reinforcement:** Synthetic textile fabrics

**Cover:** Black, abrasion and weather-resistant, SBR rubber compound

### Temperature Range

-30 °C (-22 °F) to +70 °C (+158 °F)







- Construction, general industrial
- Cover resistant to cuts, gouges, scuffs
- High working pressure
- Design Factor 3:1

### Tolerances

According to RMA steel mandrel  
Refer to Technical Handbook on page TH35

***Bold-Italic printed part numbers are stock products.***

Part Number			 Max. Working Pressure			 Weight	 min. Bend Radius	in Stock
	I.D. (mm)	O.D. (mm)	MPa	psi	bar	kg/m	mm	
<b><i>IH36822030/40</i></b>	25	38	4.0	600.0	40	0.89	300	Y
<b><i>IH36822041/40</i></b>	32	46	4.0	600.0	40	1.14	380	Y
IH36822031/40	50	66	4.0	600.0	40	1.95	600	N
IH36822050/20	65	85	4.0	600.0	40	3.04	780	N

Hose layline example

RUBBER HOSE INTONACATRICI W.P. bar



 **Material Handling**

## BETON 80

*Suitable for placement of concrete at casting locations by concrete pumps at the ends of the machine arms.*

### Hose Construction

**Tube:** Smooth, black NR/SBR compound resistant to the abrasive action of the concrete abrasion DIN 53516: max. 50±5 mm<sup>3</sup>

**Reinforcement:** Steel wire cord plies

**Cover:** Black, smooth, weather and abrasion resistant NR/SBR rubber compound

### Temperature Range

-40 °C (-40 °F) to +70 °C (+158 °F)



- Flexibility and kink resistance also for easy cleaning
- Wet abrasive materials
- High abrasion resistant tube assures longer service life
- Dedicated fitting series
- Design Factor 2.5:1

### Tolerances

On outside diameter





According to RMA steel mandrel

On inside diameter

According to UNI EN ISO 1307

Refer to Technical Handbook on page TH35

***Bold-Italic printed part numbers are stock products.***

Part Number			 Max. Working Pressure	Weight			 min. Bend Radius	in Stock
	I.D. (mm)	O.D. (mm)		MPa	psi	bar		
<b><i>IH36827051/0</i></b>	51	75	8	1200	80	3.96	380	Y
<b><i>IH36827052/0</i></b>	65	89	8	1200	80	4.84	400	Y
IH36827053/0	76	100	8	1200	80	5.4	400	N
IH36827054/0	100	124	8	1200	80	7.04	550	N
IH36827055/0	125	150	8	1200	80	8.9	700	N

Hose layline example

RUBBER HOSE BETON 80





## CERCOM

### Parker Global Product

*Suitable for pneumatic suction and delivery of dry cement, coal, CDR (fuel by-waste material), minerals, ceramic powder, glass recovery, fibreglass, and to load tankers and storage bins or silos. Applications in the industries: steelworks, cookery, thermoelectric power plant, cement works, mining industries, ceramic works, glassworks, insulating material manufactures etc. Supplied in customized lengths.*

### Hose Construction

- Tube:** Ceramic hexagonal plates (sinterized Alumina Oxide) processed to match black BR/NR rubber compound, highly resistant to abrasion
- Reinforcement:** Synthetic textile fabrics, embedded steel wire helix and built-in copper wires to provide electrical continuity between both ends
- Cover:** Black, antistatic (R < 2.0 MΩ/m), abrasion and weather-resistant, SBR/NBR rubber compound







- Parker International Patent PCT-EP2007-057488
- Outstanding resistance at the abrasion
- Unique construction provides service life many times longer than traditional rubber hoses
- Reduces operations, logistics and admin costs
- Customized assemblies with built-in tech
- Design Factor 3:1

### Temperature Range

-30 °C (-22 °F) to +70 °C (+158 °F)

### Tolerances

Length tolerance ± 1 %

Part Number	 I.D. (mm)	 O.D. (mm)	 Max. Working Pressure			 Weight	 min. Bend Radius	in Stock
			MPa	psi	bar			
IH36829020/0	25	49	1.0	145.0	10	2.59	375	N
IH36829021/0	32	56	1.0	145.0	10	3.07	480	N
IH36829022/0	38	62	1.0	145.0	10	3.48	570	N
IH36829023/0	42	66	1.0	145.0	10	3.75	630	N
IH36829024/0	48	72	1.0	145.0	10	4.17	720	N
IH36829025/0	50	74	1.0	145.0	10	4.31	750	N
IH36829026/0	60	86	1.0	145.0	10	5.27	900	N
IH36829027/0	63.5	90	1.0	145.0	10	5.54	953	N
IH36829028/0	70	100	1.0	145.0	10	6.00	1050	N
IH36829029/0	75	105	1.0	145.0	10	6.35	1125	N
IH36829030/0	80	110	1.0	145.0	10	6.93	1200	N
IH36829031/0	100	132	1.0	145.0	10	8.56	1500	N
IH36829032/0	114	147	1.0	145.0	10	13.24	1710	N
IH36829033/0	125	158	1.0	145.0	10	14.42	1875	N
IH36829034/0	150	188	1.0	145.0	10	19.42	2250	N
IH36829035/0	200	240	1.0	145.0	10	27.68	3045	N

Hose layline example



 **Material Handling**

## ASPIREX

*Suitable for suction of air, dust, fumes, saw-dust and wood-shavings. Also suitable for centralized suction equipment in wood, textile, china and welding equipment. It is also suitable for use on agricultural machinery.*

### Hose Construction

Flexible hose having a grey, rigid PVC spiral embedded in a metalized grey, flexible PVC wall. Externally corrugated, smooth inner surface. Self-extinguishing.

### Temperature Range

-15 °C (+5 °F) to +60 °C (+140 °F)







- Self-extinguishing hose
- General purpose hose
- Not to be used under pressure
- Vacuum 0.75 bar for ID up to 50 mm then 0.40 bar

### Tolerances

Refer to Technical Handbook on page TH35

***Bold-Italic printed part numbers are stock products.***

Part Number	 I.D. (mm)	 Wall (mm)	 Max. Working Pressure			 Weight kg/m	 min. Bend Radius mm	in Stock
			MPa	psi	bar			
IH35560020/50	20	2.6	–	–	–	0.14	20	N
IH35560025/50	25	2.9	–	–	–	0.18	25	N
IH35562032/50	32	3.3	–	–	–	0.27	32	N
<b><i>IH35560040/50</i></b>	40	3.9	–	–	–	0.36	40	Y
<b><i>IH35560050/50</i></b>	50	4.2	–	–	–	0.52	50	Y
<b><i>IH35560060/50</i></b>	60	4.4	–	–	–	0.64	60	Y
<b><i>IH35560070/50</i></b>	70	4.8	–	–	–	0.76	70	Y
<b><i>IH35560080/50</i></b>	80	5.0	–	–	–	0.97	80	Y
<b><i>IH35560100/30</i></b>	100	5.3	–	–	–	1.27	100	Y
IH35560120/30	120	5.6	–	–	–	1.58	120	N
IH35560150/30	150	5.9	–	–	–	2.15	150	N
IH35562160/30	160	6.1	–	–	–	2.28	160	N
IH35560200/15	200	7.0	–	–	–	2.95	200	N
IH35560250/15	250	8.0	–	–	–	4.00	250	N

Hose layline example

ASPIREX I.D. mm - SELF-EXTINGUISHING - PARKER

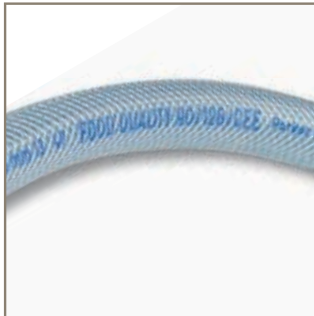
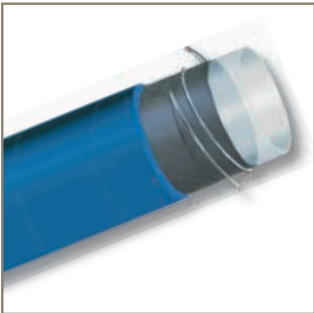

## Beverage & Food



 Beverage & Food

## H – Beverage & Food

Hose	ID Range (mm)	Temp. Range (°C)	Application
DRINKPRESS WB/L 10	10 - 25	-20 / +100	food & beverage, wash-down
GAMBRINUS UPE SM EN12115	19 - 100	-20 / +100	food & beverage
GAMBRINUS BLUE 10	19 - 102	-30 / +80	fatty food & beverage
GAMBRINUS BLUE SM 10	19 - 102	-30 / +80	fatty food & beverage
GAMBRINUS RED SM 10	19 - 102	-40 / +120	wine and soft drinks food & beverage
VINITRESS	6 - 50	-20 / +60	food & beverage
APERSPIR	12 - 150	-10 / +60	food & beverage
ENOREX	25 - 120	-25 / +60	wine and soft drinks food & beverage

## Guidelines to the use and cleaning of food rubber hose

Refer to Technical Handbook on page TH13



Tube	Reinforcement	Cover	WP (bar)	Design Factor	Suction	Industry standard	Page
NBR	textile	NBR/PVC	10	4		FDA - EC	H4
UHMWPE	textile + copper wires	EPDM	16	4	yes	**EN12115-FDA-DM	H5
NBR	textile	NBR/PVC	10	3		* BfR - DM - FDA - EC	H6
NBR	textile	NBR/PVC	10	3	yes	* BfR - DM - FDA - EC	H7
EPDM	textile	EPDM	10	3	yes	* BfR - DM - FDA - EC	H8
PVC	textile	PVC	20	3		EC 90/128 CLASS A-B-C	H9
PVC	steel wire	PVC	15	3	yes	EC 90/128 CLASS A-B-C	H10
PVC	PVC wire		10	3	yes	EC 1935:2004 CLASS A-B-C	H11

\* BfR Class2 - DM 21/03/73 - FDA title21 - EC 1935/2004

\*\* EN 12115 - FDA title21 - DM 21/03/73 - DM 220 26/04/93



 Beverage & Food

## DRINKPRESS WB/L 10

*Designed for delivery of all foodstuffs containing vegetable fats and fluids as well as beverages such as wine, fruit juices and liqueurs. Also suitable for wash-down in food processing with hot water.*

### Hose Construction

- Tube:** White, smooth, NBR food quality rubber compound
- Reinforcement:** High tensile synthetic yarns
- Cover:** Blue, smooth, abrasion, vegetable fats, ozone and weather resistant NBR/PVC rubber compound

### Temperature Range

-30 °C (-22 °F) to +110 °C (+230 °)







- Multipurpose food grade hose
- According to FDA 21 – EC 1935/2006
- Versatility of use, food transfer, wash-down applications
- Design Factor 3:1

### Tolerances

According to UNI EN ISO 1307/97  
Refer to Technical Handbook on page TH35

***Bold-Italic printed part numbers are stock products.***

Part Number				Max. Working Pressure					in Stock
	I.D. (mm)	O.D. (mm)		MPa	psi	bar			
IH30240022/40	10	19	1	150	10	0.31	80	N	
<b><i>IH30240020/40</i></b>	13	23	1	150	10	0.42	105	Y	
IH30240025/40	16	26	1	150	10	0.49	130	N	
<b><i>IH30240030/40</i></b>	19	30	1	150	10	0.71	150	Y	
IH30240035/40	25	36	1	150	10	1.05	200	N	

Hose layline example



## GAMBRINUS UPE SM EN 12115

According to EN 12115

*Designed to handle all beverages such milk, mineral water, fruit juices, wine, liqueurs etc., as well as animal or vegetable fats and oils. It is also suitable for sanitary materials. UHMWPE tube does not leach into and contaminate the product conveyed. Suitable for suction and delivery.*

### Hose Construction

- Tube:** Smooth, white undercoat, ultra high molecular weight translucent polyethylene (UHMWPE), suitable for foodstuff contact
- Reinforcement:** Synthetic textile fabrics with embedded steel wire helix and copper wire to allow electrical connection between hose and couplings
- Cover:** Blue, abrasion and weather resistant EPDM rubber compound



- According to EN 12115 - FDA title 21 - DM 21/03/73 - DM 220 26/04/93
- Compatibility with all liquid foodstuffs & outstanding performance in one solution
- Design Factor 4:1
- Vacuum: 0.8 bar max





### Tolerances

According to EN 12115  
Refer to Technical Handbook on page TH35

### Temperature Range

-20 °C (-4 °F) to +100 °C (+212 °F)  
sterilization at 130 °C for short periods

***Bold-Italic printed part numbers are stock products.***

Part Number				Max. Working Pressure					in Stock
	I.D. (mm)	O.D. (mm)		MPa	psi	bar			
IH36242301/40	19	31	1.6	232.0	16	0.70	190	N	
<b><i>IH36242302/40</i></b>	25	37	1.6	232.0	16	0.90	225	Y	
<b><i>IH36242303/40</i></b>	32	44	1.6	232.0	16	1.20	260	Y	
<b><i>IH36242304/40</i></b>	38	51	1.6	232.0	16	1.50	335	Y	
<b><i>IH36242305/40</i></b>	50	66	1.6	232.0	16	2.20	410	Y	
IH36242306/40	63.5	79	1.6	232.0	16	2.80	450	N	
<b><i>IH36242307/40</i></b>	75	91	1.6	232.0	16	3.30	525	Y	
IH36242309/40	100	116	1.2	180.0	12	4.70	675	N	

Hose layline example

 Beverage & Food

## GAMBRINUS BLUE 10

*Designed to handle fatty foods, milk in a variety of transfer and delivery applications, including milk collection.*

### Hose Construction

**Tube:** White, smooth NBR Phthalates free rubber compound, non-toxic, odorless and taste-free. Manufactured on stainless steel mandrel for the maximum cleanliness, hygienic standards and a bacteria-free surface.

**Reinforcement:** Synthetic textile fabrics

**Cover:** Blue NBR/PVC rubber compound, non-marking, abrasion and weather-resistant

### Temperature Range

-30 °C (-22 °F) to +80 °C (+176 °F)  
sterilization at 110 °C for max 10 min.



- According to FDA, BfR class 2, DM 21/03/73, EC 1935/2004
- Indoors and outdoors
- ADI free
- Design Factor 3:1





### Tolerances

According to RMA steel mandrel  
Refer to Technical Handbook on page TH35

### Fitting Series

IF stainless steel

***Bold-Italic printed part numbers are stock products.***

Part Number				Max. Working Pressure					in Stock
	I.D. (mm)	O.D. (mm)		MPa	psi	bar			
<b><i>IH36242431/40</i></b>	19	29	1.0	150.0	10	0.67	120	Y	
<b><i>IH36242432/40</i></b>	25	36	1.0	150.0	10	0.80	150	Y	
<b><i>IH36242434/40</i></b>	32	44	1.0	150.0	10	1.23	190	Y	
<b><i>IH36242435/40</i></b>	38	50	1.0	150.0	10	1.38	240	Y	
<b><i>IH36242436/40</i></b>	40	52	1.0	150.0	10	1.41	250	Y	
IH36242437/40	45	57	1.0	150.0	10	1.62	310	N	
<b><i>IH36242438/40</i></b>	51	64	1.0	150.0	10	1.88	350	Y	
IH36242439/40	60	73	1.0	150.0	10	2.24	410	N	
IH36242440/40	63.5	77	1.0	150.0	10	2.60	450	N	
IH36242441/40	70	83	1.0	150.0	10	2.86	550	N	
IH36242442/40	76	89	1.0	150.0	10	3.00	600	N	
IH36242443/40	80	93	1.0	150.0	10	3.17	630	N	
IH36242444/20	102	116	1.0	150.0	10	4.60	750	N	

Hose layline example



## GAMBRINUS BLUE 10 SM

*Designed to handle fatty foods, milk in a variety of suction and delivery applications indoors and outdoors, including milk collection.*

### Hose Construction

**Tube:** White, smooth NBR Phthalates free rubber compound, non-toxic, odorless and taste-free.  
Manufactured on stainless steel mandrel for the maximum cleanliness, hygienic standards and a bacteria-free surface.

**Reinforcement:** Synthetic textile fabrics and embedded steel wire helix

**Cover:** Blue NBR/PVC rubber compound, non-marking, abrasion and weather-resistant.

### Temperature Range

-30 °C (-22 °F) to +80 °C (+176 °F)  
sterilization at 110 °C for max 10 min.



- According to FDA, BfR class 2, DM 21/03/73, EC 1935/2004
- Excellent flexibility, kink resistance, easy handling
- ADI free
- Design Factor 3:1
- Vacuum: 0.9 bar

### Tolerances

According to RMA steel mandrel  
Refer to Technical Handbook on page TH35

### Fitting Series

IF stainless steel

***Bold-Italic printed part numbers are stock products.***

Part Number	I.D. (mm)	O.D. (mm)	Max. Working Pressure			Weight kg/m	min. Bend Radius mm	in Stock
			MPa	psi	bar			
<b><i>IH36242401/40</i></b>	19	29	1.0	150.0	10	0.67	38	Y
<b><i>IH36242402/40</i></b>	25	36	1.0	150.0	10	0.80	50	Y
<b><i>IH36242404/40</i></b>	32	44	1.0	150.0	10	1.23	64	Y
<b><i>IH36242405/40</i></b>	38	50	1.0	150.0	10	1.38	76	Y
<b><i>IH36242406/40</i></b>	40	52	1.0	150.0	10	1.41	80	Y
IH36242407/40	45	57	1.0	150.0	10	1.62	90	N
<b><i>IH36242408/40</i></b>	51	64	1.0	150.0	10	1.88	102	Y
IH36242409/40	60	73	1.0	150.0	10	2.24	150	N
<b><i>IH36242410/40</i></b>	63.5	77	1.0	150.0	10	2.60	160	Y
<b><i>IH36242411/40</i></b>	65	79	1.0	150.0	10	2.66	170	Y
IH36242412/40	70	83	1.0	150.0	10	2.86	180	N
<b><i>IH36242413/40</i></b>	76	89	1.0	150.0	10	3.00	190	Y
<b><i>IH36242414/40</i></b>	80	93	1.0	150.0	10	3.17	250	Y
<b><i>IH36242415/20</i></b>	102	116	1.0	150.0	10	4.60	380	Y

Hose layline example

 Beverage & Food

## GAMBRINUS RED 10 SM

*Recommended for wine, beer, liqueurs, fruit juice and soft drinks in process, package and transfer phase. Ideal either fixed and mobile installation. Not suitable for fatty food. Designed for suction and delivery.*

### Hose Construction

**Tube:** White, smooth EPDM Phthalates free rubber compound, non-toxic, odorless and taste-free.  
Manufactured on stainless steel mandrel for the maximum cleanliness and hygienic standards

**Reinforcement:** Synthetic textile fabrics and embedded steel wire helix

**Cover:** Red EPDM rubber compound, non-marking, abrasion and weather-resistant

### Temperature Range

-40 °C (-40 °F) to +120 °C (+248 °F)  
sterilization at 130 °C for max 30 min.



- According to FDA, BfR class 2, DM 21/03/73, EC 1935/2004
- Up to 96 % alcoholic content
- Excellent flexibility, kink resistance, easy handling
- ADI free
- Crimped Stainless Steel Fittings available
- Design Factor 3:1
- Vacuum: 0.9 bar





### Tolerances

According to RMA steel mandrel  
Refer to Technical Handbook on page TH35

### Fitting Series

IF stainless steel

***Bold-Italic printed part numbers are stock products.***

Part Number				Max. Working Pressure					in Stock
	I.D. (mm)	O.D. (mm)		MPa	psi	bar			
IH36242501/40	19	29	1.0	150.0	10	0.67	80	N	
IH36242502/40	25	36	1.0	150.0	10	0.80	125	N	
IH36242503/40	30	42	1.0	150.0	10	1.11	150	N	
IH36242504/40	32	44	1.0	150.0	10	1.23	160	N	
IH36242505/40	38	50	1.0	150.0	10	1.38	190	Y	
IH36242506/40	40	52	1.0	150.0	10	1.41	200	N	
IH36242507/40	45	57	1.0	150.0	10	1.62	225	N	
IH36242508/40	51	64	1.0	150.0	10	1.88	255	Y	
IH36242509/40	60	73	1.0	150.0	10	2.24	300	N	
<b><i>IH36242510/40</i></b>	63.5	77	1.0	150.0	10	2.60	320	Y	
<b><i>IH36242511/40</i></b>	76	89	1.0	150.0	10	3.00	390	Y	
IH36242512/40	80	93	1.0	150.0	10	3.17	440	N	
IH36242513/20	102	116	1.0	150.0	10	4.60	560	N	

Hose layline example



## VINITRESS

*For delivery of foodstuff in general industrial purposes and for agriculture applications.*

### Hose Construction

Flexible, transparent PVC hose having a textile reinforcement between the walls.

### Temperature Range

-20 °C (-4 °F) TO +60 °C (140 °F)  
sterilization at 130 °C for short periods







- According to European Directive EU 10/2011 Class A, B and C
- Low duty mission profile
- Transparent structure to visually monitor the passage of media
- Design Factor 3:1

### Tolerances

Refer to Technical Handbook on page TH35

***Bold-Italic printed part numbers are stock products.***

Part Number	 I.D. (mm)	 O.D. (mm)	 Max. Working Pressure	Max. Working Pressure			 Weight	 min. Bend Radius	in Stock
				MPa	psi	bar			
<b><i>IH35033229/100</i></b>	6	12	2.0	300.0	20	0.10	40	Y	
<b><i>IH35033230/100</i></b>	8	14	2.0	300.0	20	0.13	50	Y	
<b><i>IH35033223/50</i></b>	9	15	2.0	300.0	20	0.14	50	Y	
<b><i>IH35033231/100</i></b>	10	16	2.0	300.0	20	0.15	60	Y	
<b><i>IH35033220/50</i></b>	13	19	1.2	174.0	12	0.18	80	Y	
<b><i>IH35033222/50</i></b>	15	21	1.2	174.0	12	0.21	90	Y	
<b><i>IH35033221/50</i></b>	19	26	1.0	150.0	10	0.30	110	Y	
<b><i>IH35033245/50</i></b>	25	33	0.8	116.0	8	0.44	150	Y	
IH35033241/25	32	42	0.7	101.5	7	0.71	190	N	
IH35033246/25	38	48	0.6	87.0	6	0.82	230	N	
IH35033240/25	40	50	0.6	87.0	6	0.86	240	N	

Hose layline example

VINITRESS  FOOD QUALITY - MADE IN ITALY - PARKER

 Beverage & Food

## APERSPIR

*Suitable for suction and delivery of foodstuff in general industrial purposes and for agriculture applications.*

### Hose Construction

Flexible and light hose having an harmonic steel wire helix embedded in a transparent PVC wall.

### Temperature Range

-10 °C (+14 °F) to +60 °C (+140 °F)







- According to European Directive EU 10/2011 Class A, B and C
- Medium and heavy duty mission profile
- Vacuum: 0.8 bar

### Tolerances

Refer to Technical Handbook on page TH35

***Bold-Italic printed part numbers are stock products.***

Part Number				Max. Working Pressure					in Stock
	I.D. (mm)	Wall (mm)		MPa	psi	bar			
<b><i>IH35641012/30</i></b>	12	3.1	1.5	217.5	15	0.19	20	Y	
<b><i>IH35641016/50</i></b>	16	3.1	1.5	217.5	15	0.26	30	Y	
<b><i>IH35641019/50</i></b>	19	3.5	1.2	174.0	12	0.33	40	Y	
<b><i>IH35641020/50</i></b>	20	3.5	1.2	174.0	12	0.34	40	Y	
<b><i>IH35641025/50</i></b>	25	4.2	1.1	159.5	11	0.52	50	Y	
<b><i>IH35641030/50</i></b>	30	4.2	1.0	150.0	10	0.63	60	Y	
<b><i>IH35641032/50</i></b>	32	4.5	0.95	137.75	9.5	0.66	60	Y	
<b><i>IH35641038/50</i></b>	38	4.5	0.8	116.0	8	0.80	80	Y	
<b><i>IH35641040/50</i></b>	40	5	0.8	116.0	8	0.95	80	Y	
<b><i>IH35641045/50</i></b>	45	5	0.75	108.75	7.5	1.15	90	Y	
<b><i>IH35641050/50</i></b>	50	5.4	0.7	101.5	7	1.30	100	Y	
<b><i>IH35641060/50</i></b>	60	6.1	0.6	87.0	6	1.75	120	Y	
<b><i>IH35641075/50</i></b>	75	7	0.45	65.25	4.5	2.30	150	Y	
IH35641100/30	100	8	0.3	43.5	3	3.65	200	N	
IH35641120/30	120	8	0.2	29.0	2	4.30	240	N	
IH35641125/30	125	8.3	0.2	29.0	2	4.60	250	N	
IH35641150/20	150	9.5	0.2	29.0	2	6.50	300	N	

Hose layline example

APERSPIR I.D. mm.  FOOD QUALITY - MADE IN ITALY - PARKER



## ENOREX

*Suction and delivery of wine and liquid foodstuffs in cellars, stores and docks for loading and unloading tankers and storage tankers.*

### Hose Construction

Flexible and light hose having a red, rigid PVC spiral embedded in transparent PVC wall, manufactured with materials according to EC1933/2004 European Standard for foods, and 2002/95/EC European standard RoHS.

### Temperature Range

-25 °C (-13 °F) to +60 °C (+140 °F)



- According to EU 10/2011 Class A, B and C
- Heavy duty mission profile
- Vacuum: 0.9 bar
- Design Factor 3:1

### Tolerances

Refer to Technical Handbook on page TH35

Part Number	I.D. (mm)	O.D. (mm)	Max. Working Pressure			Weight kg/m	min. Bend Radius mm	in Stock
			MPa	psi	bar			
IH35620025/50	25	34	1.0	150.0	10	0.55	125	N
IH35620030/50	30	40	1.0	150.0	10	0.65	150	N
IH35620040/50	40	50	0.9	130.5	9	0.85	200	N
IH35620050/50	50	62	0.8	116.0	8	1.20	250	N
IH35620060/50	60	72	0.75	108.8	7.5	1.60	360	N
IH35620080/50	80	94	0.65	94.25	6.5	2.20	520	N
IH35620100/25	100	116	0.5	72.5	5	3.36	650	N
IH35620120/25	120	138	0.3	43.5	3	4.20	780	N

Hose layline example









## Multipurpose & Air



**Multipurpose & Air**

# I – Multipurpose & Air

Hose	ID Range (mm)	Temp. Range (°C)	Application
GST II BLACK 15	5 - 38	-40 / +100	compressed air, non aggressive liquids
GST II RED 15	6.5 - 38	-40 / +100	compressed air, non aggressive liquids
GST II BLACK 20	6.5 - 25	-40 / +100	compressed air, non aggressive liquids
PYTHON N/L 20	10 - 50	-40 / +120	multipurpose
PYTHON NV/L 20	10 - 50	-40 / +120	multipurpose
PYTHON NY/L 30	6 - 100	-40 / +120	multipurpose
JUMBO N/L	13 - 25	-40 / +120	multipurpose
MINIERA 20 MSHA	19 - 100	-30 / +80	compressed air, non aggressive liquids
E-Z FORM™ MP	12.7 - 75	-34 / +120	high flexible hose for multipurpose
OILPRESS N/L 20	6 - 25	-35 / +100	multipurpose
OILPRESS N/L 30	6 - 25	-35 / +100	multipurpose
APERFRUT 20	8 - 19	-15 / +60	agricultural spray
APERFRUT 40	8 - 13	-15 / +60	agricultural spray
APERFRUT 80	8 - 13	-15 / +60	agricultural spray



	Tube	Reinforce- ment	Cover	WP (bar)	Design Factor	Suction	Industry standard	Page
	EPDM	textile	EPDM	15	4			I4
	EPDM	textile	EPDM	15	4			I5
	EPDM	textile	EPDM	20	4			I6
	EPDM	textile	EPDM	20	3			I7
	EPDM	textile	EPDM	20	3			I8
	EPDM	textile	EPDM	30	3			I9
	EPDM	textile	EPDM	20	3			I10
	SBR/NBR	textile	CR	20	3		MSHA	I11
	CR	textile	CR	5	4	yes		I12
	NBR	textile	NBR/PVC	20	3			I13
	NBR	textile	NBR/PVC	30	3			I13
	PVC	textile	PVC	20	4			I14
	PVC	textile	PVC	40	3			I14
	PVC	textile	PVC	80	2.5			I14

 Multipurpose & Air

## GST II BLACK 15

Parker Global Product

*In agriculture, construction, air tool lubricant systems and general industrial for air (including oil mist), mild chemicals and water. Suitable for MRO and OEM channel. Not to be used with oil or refined fuel.*

### Hose Construction

**Tube:** Black EPDM, antistatic rubber compound  
**Reinforcement:** Synthetic textile yarns.  
**Cover:** Black, smooth EPDM antistatic rubber compound resistant to abrasion, heat and ozone

### Temperature Range

-40 °C (-40 °F) to +100 °C (+212 °F)



- Nitrosamine free
- Permanent fittings capability
- EPDM compound suitable also for oil mist
- Suitable in Atex surroundings
- Design Factor 4:1







### Tolerances

According to UNI EN ISO 1307  
Refer to Technical Handbook on page TH35

### Fitting Series

64 + 47 (up to I.D. 25 mm)

***Bold-Italic printed part numbers are stock products.***

Part Number								in Stock
	I.D. (mm)	O.D. (mm)	MPa	psi	bar	kg/m	mm	
<b><i>IH709319200/40</i></b>	5	11	1.5	200.0	15	0.10	40	Y
<b><i>IH709325200/100</i></b>	6.5	13	1.5	200.0	15	0.13	50	Y
<b><i>IH709325200/40</i></b>	6.5	13	1.5	200.0	15	0.13	50	Y
<b><i>IH709331200/100</i></b>	8	15	1.5	200.0	15	0.16	65	Y
<b><i>IH709331200/40</i></b>	8	15	1.5	200.0	15	0.16	65	Y
<b><i>IH709338200/100</i></b>	9.5	17	1.5	200.0	15	0.20	75	Y
<b><i>IH709338200/40</i></b>	9.5	17	1.5	200.0	15	0.20	75	Y
<b><i>IH709350200/100</i></b>	13	21	1.5	200.0	15	0.29	105	Y
<b><i>IH709350200/40</i></b>	13	21	1.5	200.0	15	0.29	105	Y
<b><i>IH709363200/100</i></b>	16	25	1.5	200.0	15	0.36	130	Y
<b><i>IH709363200/40</i></b>	16	25	1.5	200.0	15	0.36	130	Y
<b><i>IH709375200/40</i></b>	19	28	1.5	200.0	15	0.49	150	Y
<b><i>IH7093100200/40</i></b>	25	36	1.5	200.0	15	0.69	200	Y
<b><i>IH7093125204/40</i></b>	32	45	1.5	200.0	15	1.15	230	Y
<b><i>IH7093150204/40</i></b>	38	52	1.5	200.0	15	2.76	250	Y

Hose layline example

 **SERIES 7093 GST® II ... ID (...mm) 200 PSI (15 bar) MAX WP**



## GST II RED 15

Parker Global Product

*In agriculture, construction, air tool lubricant systems and general industrial for air (including oil mist), mild chemicals and water. Suitable for MRO and OEM channel. Not to be used with oil or refined fuel..*

### Hose Construction

- Tube:** Black EPDM, antistatic rubber compound.
- Reinforcement:** Synthetic textile yarns
- Cover:** Red, smooth EPDM insulating rubber compound resistant to abrasion, heat and ozone

### Temperature Range

-40 °C (-40 °F) to +100 °C (+212 °F)



- Nitrosamine free
- Permanent fittings capability
- EPDM compound suitable also for oil mist
- Design Factor 4:1



### Tolerances

According to UNI EN ISO 1307  
Refer to Technical Handbook on page TH35

### Fitting Series

64 + 47 (up to I.D. 25 mm)

I – Multipurpose & Air

***Bold-Italic printed part numbers are stock products.***

Part Number	I.D. (mm)	O.D. (mm)	Max. Working Pressure			Weight kg/m	min. Bend Radius mm	in Stock
			MPa	psi	bar			
IH709225200/40	6.5	13	1.5	200.0	15	0.13	50	N
<b><i>IH709231200/40</i></b>	8	15	1.5	200.0	15	0.16	65	Y
<b><i>IH709238200/40</i></b>	9.5	17	1.5	200.0	15	0.20	75	N
<b><i>IH709250200/40</i></b>	13	21	1.5	200.0	15	0.29	105	Y
<b><i>IH709263200/40</i></b>	16	25	1.5	200.0	15	0.36	130	Y
<b><i>IH709275200/40</i></b>	19	28	1.5	200.0	15	0.49	150	Y
<b><i>IH7092100200/40</i></b>	25	36	1.5	200.0	15	0.69	200	Y
IH7092125204/40	32	45	1.5	200.0	15	1.15	230	N
IH7092150204/40	38	52	1.5	200.0	15	2.76	250	N

Hose layline example



 Multipurpose & Air

## GST II BLACK 20

Parker Global Product

*Designed for compressed air with traces of oil in industrial application. Also suitable in agriculture, construction, and general industry for water, mild chemicals and non aggressive fluids. Not to be used with oil or refined fuel.*

### Hose Construction

- Tube:** Black EPDM, antistatic rubber compound.
- Reinforcement:** Synthetic textile yarns.
- Cover:** Black, smooth EPDM antistatic rubber compound resistant to abrasion, heat and ozone

### Temperature Range

-40 °C (-40 °F) to +100 °C (+212 °F)



- Nitrosamine free
- Permanent fittings capability
- EPDM compound suitable also for oil mist
- Suitable in Atex surroundings
- All sizes on stock
- Design Factor 4:1







### Tolerances

According to UNI EN ISO 1307  
Refer to Technical Handbook on page TH35

### Fitting Series

64 + 47

***Bold-Italic printed part numbers are stock products.***

Part Number								in Stock
	I.D. (mm)	O.D. (mm)	MPa	psi	bar	kg/m	mm	
<b><i>IH709325300/100</i></b>	6.5	14	2.0	300.0	20	0.16	50	Y
<b><i>IH709331300/100</i></b>	8	16	2.0	300.0	20	0.20	65	Y
<b><i>IH709338300/100</i></b>	9.5	17.5	2.0	300.0	20	0.23	75	Y
<b><i>IH709350304/100</i></b>	13	22	2.0	300.0	20	0.36	105	Y
<b><i>IH709363304/100</i></b>	16	27	2.0	300.0	20	0.52	130	Y
<b><i>IH709375304/40</i></b>	19	29.5	2.0	300.0	20	0.56	150	Y
<b><i>IH7093100304/40</i></b>	25	36.5	2.0	300.0	20	0.75	200	Y

Hose layline example

 **SERIES 7093 GST® II ... ID (...mm) 300 PSI (20 bar) MAX WP**



## PYTHON N/L 20

Designed for air, cold and hot water and light-chemical media. Major properties of PYTHON hoses are:

- high ozone resistance
- antistatic resistance
- high temperature resistance
- low temperature resistance
- non-staining cover
- high flexibility

### Hose Construction

**Tube:** Black, antistatic ( $R < 10^6 \Omega/m$ ), smooth EPDM nitrosamine free rubber compound, resistant to light-chemical media

**Reinforcement:** Synthetic textile yarns

**Cover:** Black, antistatic ( $R < 10^6 \Omega/m$ ), smooth EPDM nitrosamine free rubber compound



- Antistatic tube and cover suitable for Atex applications
- Unmatchable handiness
- Wide range temperature
- Its versatility of use helps to keep a controlled stock
- Nitrosamine free
- Design Factor 3:1



### Temperature Range

-40 °C (-40 °F) to +120 °C (+248 °F)  
with peaks to +140 °C (+284 °F)

### Tolerances

I.D.  $\leq$  25 mm according to UNI EN ISO 1307  
I.D.  $>$  25 mm according to RMA steel mandrel  
Refer to Technical Handbook on page TH35

### Fitting Series

64 + 47 (up to I.D. 25 mm)  
48 (from I.D. 32 up to 50 mm)

***Bold-Italic printed part numbers are stock products.***

Part Number	I.D. (mm)	O.D. (mm)	Max. Working Pressure			Weight kg/m	min. Bend Radius mm	in Stock
			MPa	psi	bar			
IH30351270/40	10	17	2.0	300.0	20	0.22	60	N
<b><i>IH30351271/40</i></b>	13	20	2.0	300.0	20	0.26	80	N
IH30351272/40	15	22	2.0	300.0	20	0.29	90	Y
<b><i>IH30351273/40</i></b>	19	27	2.0	300.0	20	0.41	110	Y
<b><i>IH30351274/40</i></b>	25	34	2.0	300.0	20	0.60	150	Y
IH36351270/40	32	44	2.0	300.0	20	0.98	320	N
IH36351271/40	38	51	2.0	300.0	20	1.20	380	N
IH36351272/40	50	66	2.0	300.0	20	1.76	500	N

Hose layline example





 Multipurpose & Air

## PYTHON NV/L 20

Designed for air, cold and hot water and light-chemical media. Major properties of PYTHON hoses are:

- high ozone resistance
- antistatic resistance
- high temperature resistance
- low temperature resistance
- non-staining cover
- high flexibility

### Hose Construction

**Tube:** Black, antistatic, smooth EPDM nitrosamine free rubber compound, resistant to light-chemical media

**Reinforcement:** Synthetic textile yarns

**Cover:** Green, smooth EPDM nitrosamine free rubber compound

### Temperature Range

-40 °C (-40 °F) to +120 °C (+248 °F)  
with peaks to +140 °C (+284 °F)



- Unmatchable handiness
- Its versatility of use helps to keep a controlled stock
- Wide range temperature
- Nitrosamine free
- Design Factor 3:1







### Tolerances

I.D. ≤ 25 mm according to UNI EN ISO 1307  
I.D. > 25 mm according to RMA steel mandrel  
*Refer to Technical Handbook on page TH35*

### Fitting Series

64 + 47 (up to I.D. 25 mm)  
48 (from I.D. 32 up to 50 mm)

***Bold-Italic printed part numbers are stock products.***

Part Number								in Stock
	I.D. (mm)	O.D. (mm)	MPa	psi	bar	kg/m	min. Bend Radius (mm)	
<b><i>IH30351200/40</i></b>	10	17	2.0	300.0	20	0.22	60	Y
<b><i>IH30351201/40</i></b>	13	20	2.0	300.0	20	0.26	80	Y
<b><i>IH30351202/40</i></b>	15	22	2.0	300.0	20	0.29	90	Y
<b><i>IH30351203/40</i></b>	19	27	2.0	300.0	20	0.41	110	Y
<b><i>IH30351204/40</i></b>	25	34	2.0	300.0	20	0.60	150	Y
<b><i>IH36351201/40</i></b>	32	44	2.0	300.0	20	0.98	320	Y
<b><i>IH36351202/40</i></b>	38	51	2.0	300.0	20	1.20	380	Y
<b><i>IH36351203/40</i></b>	42	56	2.0	300.0	20	1.42	420	Y
<b><i>IH36351204/40</i></b>	50	66	2.0	300.0	20	1.76	500	Y

Hose layline example





## PYTHON NY/L 30

Designed for air, cold and hot water and light-chemical media. Major properties of PYTHON hoses are:

- high ozone resistance
- antistatic resistance
- high temperature resistance
- low temperature resistance
- non-staining cover
- high flexibility

### Hose Construction

**Tube:** Black, antistatic, smooth EPDM nitrosamine free rubber compound, resistant to light-chemical media

**Reinforcement:** Synthetic textile yarns

**Cover:** Yellow, smooth EPDM nitrosamine free rubber compound

### Temperature Range

-40 °C (-40 °F) to +120 °C (+248 °F)  
with peaks to +140 °C (+284 °F)



- Unmatchable handiness
- Its versatility of use helps to keep a controlled stock
- Wide range temperature
- Nitrosamine free
- Design Factor 3:1



### Tolerances

I.D. ≤ 25 mm according to UNI EN ISO 1307  
I.D. > 25 mm according to RMA steel mandrel  
*Refer to Technical Handbook on page TH35*

### Fitting Series

64 + 47 (up to I.D. 25 mm)  
48 (from I.D. 32 up to 50 mm)

***Bold-Italic printed part numbers are stock products.***

Part Number	I.D. (mm)	O.D. (mm)	Max. Working Pressure			Weight kg/m	min. Bend Radius mm	in Stock
			MPa	psi	bar			
<b><i>IH30351250/40</i></b>	6	14	3.0	450.0	30	0.18	40	Y
<b><i>IH30351251/40</i></b>	8	17	3.0	450.0	30	0.25	50	Y
<b><i>IH30351252/40</i></b>	10	20	3.0	450.0	30	0.34	60	Y
<b><i>IH30351253/40</i></b>	13	23	3.0	450.0	30	0.40	80	Y
<b><i>IH30351254/40</i></b>	16	27	3.0	450.0	30	0.52	100	Y
<b><i>IH30351255/40</i></b>	19	30	3.0	450.0	30	0.60	110	Y
<b><i>IH30351256/40</i></b>	25	37	3.0	450.0	30	0.88	150	Y
<b><i>IH36351250/40</i></b>	32	44	3.0	450.0	30	0.95	320	Y
<b><i>IH36351251/40</i></b>	38	51	3.0	450.0	30	1.20	380	Y
IH36351252/40	42	56	3.0	450.0	30	1.45	420	N
<b><i>IH36351253/40</i></b>	50	66	3.0	450.0	30	1.93	500	Y
IH36351254/20	65	82	3.0	450.0	30	2.50	650	N
IH36351255/20	76	92	3.0	450.0	30	3.08	750	N
IH36351256/20	100	122	3.0	450.0	30	5.05	1000	N

Hose layline example



 Multipurpose & Air

## JUMBO

*Suitable for the discharge of hot and cold water, air and light-chemical media in many industrial and agricultural applications.*

### Hose Construction

- Tube:** Black, smooth EPDM nitrosamine free rubber compound
- Reinforcement:** Synthetic textile yarns
- Cover:** Black, smooth EPDM nitrosamine free rubber compound with three red, longitudinal and different stripes, resistant to abrasion, heat and weathering

### Temperature Range

-40 °C (-40 °F) to +120 °C (+248 °F)



- Agriculture, construction and general industrial
- Long lasting embossed type branding
- Three red stripes for easy hose identification
- Nitrosamine free
- Design Factor 3:1







### Tolerances

According to UNI EN ISO 1307  
Refer to Technical Handbook on page TH35

### Fitting Series

64 + 47

***Bold-Italic printed part numbers are stock products.***

Part Number	 I.D. (mm)	 O.D. (mm)	 Max. Working Pressure			 Weight kg/m	 min. Bend Radius mm	in Stock
			MPa	psi	bar			
<b><i>IH30116500/40</i></b>	13	19	2.0	300.0	20	0.21	75	Y
<b><i>IH30116501/40</i></b>	15	22	2.0	300.0	20	0.28	90	Y
<b><i>IH30116502/40</i></b>	19	27	2.0	300.0	20	0.40	110	Y
<b><i>IH30116504/40</i></b>	25	34	2.0	300.0	20	0.57	150	Y

Hose layline example

JUMBO (logo) WASSERSCHLAUCH (logo) JUMBO 20 bar Ø mm, MAX 120°C



## MINIERA 20 MSHA

Suitable for compressed air tools in factories and designed for quarries, building and mining industries. Tube resistant to traces of oil mist for medium duty.

### Hose Construction

- Tube:** Black, oil mist resistant, smooth SBR/NBR rubber compound
- Reinforcement:** Synthetic textile fabrics
- Cover:** Black, abrasion, ageing and weather-resistant CR nitrosamine free rubber compound

### Temperature Range

-30 °C (-22 °F) to +80 °C (+176 °F)







- Also suitable for water and air in general service applications
- Nitrosamine free compounds 
- Design Factor 3:1
- MSHA approved cover

### Tolerances

According to RMA steel mandrel  
Refer to Technical Handbook on page TH35

***Bold-Italic printed part numbers are stock products.***

Part Number	 I.D. (mm)	 O.D. (mm)	 Max. Working Pressure			 Weight kg/m	 min. Bend Radius mm	in Stock
			MPa	psi	bar			
<b><i>IH36342161/40</i></b>	19	30	2.0	300.0	20	0.62	190	Y
<b><i>IH36342162/40</i></b>	25	37	2.0	300.0	20	0.81	250	Y
IH36342163/40	30	42	2.0	300.0	20	0.98	300	N
<b><i>IH36342164/40</i></b>	32	46	2.0	300.0	20	1.24	320	Y
IH36342165/40	38	52	2.0	300.0	20	1.43	380	N
IH36342166/40	40	56	2.0	300.0	20	1.73	400	N
IH36342167/40	45	61	2.0	300.0	20	1.91	450	N
<b><i>IH36342168/40</i></b>	50	66	2.0	300.0	20	2.08	500	Y
IH36342169/40	60	76	2.0	300.0	20	2.38	600	N
IH36342170/20	75	91	2.0	300.0	20	2.89	750	N
IH36342171/20	100	118	2.0	300.0	20	4.23	1000	N

Hose layline example

RUBBER AIR HOSE MINIERA 20 bar MSHA



 Multipurpose & Air

## E-Z FORM™ MP

Parker Global Product

*Suitable for biodiesel, diesel, ethanol and gasoline in oil suction/return lines, vehicle fuel fill connector lines, drain lines on buses, cranes, mobile off-road equipment. Extremely flexible and lightweight it reduces installation times, eliminates special design, tooling and fabrication cost. Capable of being routed through confined spaces where pre-shaped and formed hose are normally required. Do not use for fuel dispensing or drag across sharp edges or very abrasive surfaces.*

### Hose Construction

- Tube:** Black CR, antistatic rubber compound (up to I.D. 25 mm NBR)
- Reinforcement:** Multiple textile plies with wire helix
- Cover:** Black, Greek corrugated CR rubber compound resistant to oil and weathering (up to I.D. 25 mm NBR)



- Saves time and costs thanks to easy and quick assembly
- Superior kink resistance, minimal force to bend, outstanding flexibility
- Permanent fittings capability
- Design Factor 4:1
- Vacuum: 0.9 bar

### Tolerances

According to UNI EN ISO 1307  
Refer to Technical Handbook on page TH35





### Fitting Series

48 (up to I.D. 51 mm)

### Temperature Range

ID up to 25 mm: -34 °C (-30 °F) to +121 °C (+250 °F)  
all other sizes: -29 °C (-20 °F) to +93 °C (+200 °F)

***Bold-Italic printed part numbers are stock products.***

Part Number								in Stock
	I.D. (mm)	O.D. (mm)	MPa	psi	bar			
<b><i>IH72190500/10</i></b>	12.7	23.8	0.5	75	5	0.45	23	Y
<b><i>IH72190625/10</i></b>	15.9	27.0	0.5	75	5	0.55	33	Y
<b><i>IH72190750/10</i></b>	19.1	30.0	0.5	75	5	0.58	36	Y
<b><i>IH72191000/10</i></b>	25.4	36.0	0.5	75	5	0.68	36	Y
<b><i>IH72191250/10</i></b>	32.0	43.0	0.5	75	5	0.75	56	Y
<b><i>IH72191500/10</i></b>	38.0	49.0	0.5	75	5	0.85	74	Y
<b><i>IH72192000/10</i></b>	51.0	63.0	0.5	75	5	1.44	117	Y
<b><i>IH72192500/10</i></b>	63.5	76.5	0.5	75	5	1.74	183	Y
<b><i>IH72193000/10</i></b>	76.0	90.0	0.5	75	5	2.23	223	Y

Hose layline example

 **SERIES 7219 E-Z FORM MP HOSE 75 PSI MAX WP**



## OILPRESS N/L 20 - 30

Suitable for multi-purpose applications requiring transfer of many types of fluids and for petroleum products with aromatic content not exceeding 50 %.

### Hose Construction

- Tube:** Smooth, black, oil and fuel resistant NBR rubber compound, suitable for petroleum products with aromatic content not exceeding 50 %
- Reinforcement:** Synthetic textile yarns
- Cover:** Smooth, black, self-extinguishing, antistatic ( $R < 1 \text{ M}\Omega/\text{m}$ ) heat, oil, abrasion and weather resistant NBR/PVC rubber compound

### Temperature Range

-35 °C (-31 °F) to +100 °C (+212 °F),  
with peaks up to +120 °C (+248 °F) for oil



- Agriculture, construction and general industrial
- Suitable for many different fuels included Biodiesel B100
- Two different Working Pressure lines
- Wide range temperature
- Design Factor 3:1





### Tolerances

According to UNI EN ISO 1307  
Refer to Technical Handbook on page TH35

### Fitting Series

64 + 47

***Bold-Italic printed part numbers are stock products.***

Part Number	 I.D. (mm)	 O.D. (mm)	 Max. Working Pressure			 Weight kg/m	 min. Bend Radius mm	in Stock
			MPa	psi	bar			
<b>OILPRESS N/L 20</b>								
<b><i>IH30832000/40</i></b>	6	12	2.0	300.0	20	0.12	25	Y
<b><i>IH30832001/40</i></b>	8	14	2.0	300.0	20	0.15	35	Y
<b><i>IH30832002/40</i></b>	10	17	2.0	300.0	20	0.21	40	Y
<b><i>IH30832003/40</i></b>	13	20	2.0	300.0	20	0.26	55	Y
<b><i>IH30832004/40</i></b>	16	23	2.0	300.0	20	0.31	65	Y
<b><i>IH30832005/40</i></b>	19	28	2.0	300.0	20	0.47	80	Y
<b><i>IH30832006/40</i></b>	25	36	2.0	300.0	20	0.74	100	Y
<b>OILPRESS N/L 30</b>								
<b><i>IH30832031/40</i></b>	6	14	3.0	450.0	30	0.18	25	N
<b><i>IH30832032/40</i></b>	8	16	3.0	450.0	30	0.21	30	N
<b><i>IH30832038/40</i></b>	9	17	3.0	450.0	30	0.24	35	N
<b><i>IH30832033/40</i></b>	10	18	3.0	450.0	30	0.25	40	Y
<b><i>IH30832034/40</i></b>	13	23	3.0	450.0	30	0.40	55	Y
<b><i>IH30832035/40</i></b>	16	27	3.0	450.0	30	0.47	65	N
<b><i>IH30832036/40</i></b>	19	30	3.0	450.0	30	0.60	80	N
<b><i>IH30832039/40</i></b>	25	37	3.0	450.0	30	0.83	100	N

Hose layline example

RUBBER HOSE OILPRESS W.P. bar R<1MΩ  MCXX

 Multipurpose & Air

## APERFRUT 20 - 40 - 80

For delivery of air, water and all fungicide products. Particularly suitable for spraying in agriculture. Resistant to compressor oil-mist.

### Hose Construction

**Tube:** Black, smooth, PVC compound  
**Reinforcement:** Synthetic textile yarns  
**Cover:** Orange (20), red (40) and blue (80), smooth, abrasion, and weather-resistant PVC compound

### Temperature Range

-15 °C (+5 °F) to +60 °C (+140 °F)







- Colored cover to distinguish WP level
- Multiple fluids for various industrial applications
- Design Factor 3:1 for 20 and 40 bar
- Design Factor 2.5:1 for 80 bar

### Tolerances

Refer to Technical Handbook on page TH35

***Bold-Italic printed part numbers are stock products.***

Part Number			 Max. Working Pressure			 Weight	 min. Bend Radius	in Stock
	I.D. (mm)	O.D. (mm)	MPa	psi	bar	kg/m	mm	
<b>APERFRUT 20</b>								
<b><i>IH35040010/100</i></b>	8	13	2.0	300.0	20	0.11	30	Y
<b><i>IH35040012/100</i></b>	10	15	2.0	300.0	20	0.14	55	Y
<b><i>IH35040014/100</i></b>	13	19	2.0	300.0	20	0.20	85	Y
<i>IH35040015/100</i>	16	23	2.0	300.0	20	0.29	90	N
<b><i>IH35040016/100</i></b>	19	26.5	2.0	300.0	20	0.33	100	Y
<b>APERFRUT 40</b>								
<b><i>IH35040260/100</i></b>	8	14	4.0	600.0	40	0.14	30	Y
<b><i>IH35040261/100</i></b>	10	16	4.0	600.0	40	0.17	50	Y
<b><i>IH35040114/100</i></b>	13	21	4.0	600.0	40	0.29	80	Y
<b>APERFRUT 80</b>								
<b><i>IH35040268/100</i></b>	8	15	8.0	1200.0	80	0.17	25	Y
<b><i>IH35040270/100</i></b>	10	18	8.0	1200.0	80	0.23	45	Y
<b><i>IH35040214/100</i></b>	13	23	7.0	1015.0	70	0.38	60	Y

Hose layline example











# Parker's Motion & Control Technologies

**At Parker, we're guided by a relentless drive to help our customers become more productive and achieve higher levels of profitability by engineering the best systems for their requirements. It means looking at customer applications from many angles to find new ways to create value. Whatever the motion and control technology need, Parker has the experience, breadth of product and global reach to consistently deliver. No company knows more about motion and control technology than Parker.**

**For further info call  
00800 27 27 5374**



## Aerospace

### Key Markets

Aftermarket services  
Commercial transports  
Engines  
General & business aviation  
Helicopters  
Launch vehicles  
Military aircraft  
Missiles  
Power generation  
Regional transports  
Unmanned aerial vehicles

### Key Products

Control systems & actuation products  
Engine systems & components  
Fluid conveyance systems & components  
Fluid metering, delivery & atomization devices  
Fuel systems & components  
Fuel tank inerting systems  
Hydraulic systems & components  
Thermal management  
Wheels & brakes



## Climate Control

### Key Markets

Agriculture  
Air conditioning  
Construction Machinery  
Food & beverage  
Industrial machinery  
Life sciences  
Oil & gas  
Precision cooling  
Process  
Refrigeration  
Transportation

### Key Products

Accumulators  
Advanced actuators  
CO<sub>2</sub> controls  
Electronic controllers  
Filter driers  
Hand shut-off valves  
Heat exchangers  
Hose & fittings  
Pressure regulating valves  
Refrigerant distributors  
Safety relief valves  
Smart pumps  
Solenoid valves  
Thermostatic expansion valves



## Hydraulics

### Key Markets

Aerial lift  
Agriculture  
Alternative energy  
Construction machinery  
Forestry  
Industrial machinery  
Machine tools  
Marine  
Material handling  
Mining  
Oil & gas  
Power generation  
Refuse vehicles  
Renewable energy  
Truck hydraulics  
Turf equipment

### Key Products

Accumulators  
Cartridge valves  
Electrohydraulic actuators  
Human machine interfaces  
Hybrid drives  
Hydraulic cylinders  
Hydraulic motors & pumps  
Hydraulic systems  
Hydraulic valves & controls  
Hydrostatic steering  
Integrated hydraulic circuits  
Power take-offs  
Power units  
Rotary actuators  
Sensors



## Pneumatics

### Key Markets

Aerospace  
Conveyor & material handling  
Factory automation  
Life science & medical  
Machine tools  
Packaging machinery  
Transportation & automotive

### Key Products

Air preparation  
Brass fittings & valves  
Manifolds  
Pneumatic accessories  
Pneumatic actuators & grippers  
Pneumatic valves & controls  
Quick disconnects  
Rotary actuators  
Rubber & thermoplastic hose & couplings  
Structural extrusions  
Thermoplastic tubing & fittings  
Vacuum generators, cups & sensors



### Electromechanical

#### Key Markets

Aerospace  
Factory automation  
Life science & medical  
Machine tools  
Packaging machinery  
Paper machinery  
Plastics machinery & converting  
Primary metals  
Semiconductor & electronics  
Textile  
Wire & cable

#### Key Products

AC/DC drives & systems  
Electric actuators, gantry robots & slides  
Electrohydraulic actuation systems  
Electromechanical actuation systems  
Human machine interface  
Linear motors  
Stepper motors, servo motors, drives & controls  
Structural extrusions



### Filtration

#### Key Markets

Aerospace  
Food & beverage  
Industrial plant & equipment  
Life sciences  
Marine  
Mobile equipment  
Oil & gas  
Power generation & renewable energy  
Process  
Transportation  
Water Purification

#### Key Products

Analytical gas generators  
Compressed air filters & dryers  
Engine air, coolant, fuel & oil filtration systems  
Fluid condition monitoring systems  
Hydraulic & lubrication filters  
Hydrogen, nitrogen & zero air generators  
Instrumentation filters  
Membrane & fiber filters  
Microfiltration  
Sterile air filtration  
Water desalination & purification filters & systems



### Fluid & Gas Handling

#### Key Markets

Aerial lift  
Agriculture  
Bulk chemical handling  
Construction machinery  
Food & beverage  
Fuel & gas delivery  
Industrial machinery  
Life sciences  
Marine  
Mining  
Mobile  
Oil & gas  
Renewable energy  
Transportation

#### Key Products

Check valves  
Connectors for low pressure fluid conveyance  
Deep sea umbilicals  
Diagnostic equipment  
Hose couplings  
Industrial hose  
Mooring systems & power cables  
PTFE hose & tubing  
Quick couplings  
Rubber & thermoplastic hose  
Tube fittings & adapters  
Tubing & plastic fittings



### Process Control

#### Key Markets

Alternative fuels  
Biopharmaceuticals  
Chemical & refining  
Food & beverage  
Marine & shipbuilding  
Medical & dental  
Microelectronics  
Nuclear Power  
Offshore oil exploration  
Oil & gas  
Pharmaceuticals  
Power generation  
Pulp & paper  
Steel  
Water/wastewater

#### Key Products

Analytical Instruments  
Analytical sample conditioning products & systems  
Chemical injection fittings & valves  
Fluoropolymer chemical delivery fittings, valves & pumps  
High purity gas delivery fittings, valves, regulators & digital flow controllers  
Industrial mass flow meters/controllers  
Permanent no-weld tube fittings  
Precision industrial regulators & flow controllers  
Process control double block & bleeds  
Process control fittings, valves, regulators & manifold valves



### Sealing & Shielding

#### Key Markets

Aerospace  
Chemical processing  
Consumer  
Fluid power  
General industrial  
Information technology  
Life sciences  
Microelectronics  
Military  
Oil & gas  
Power generation  
Renewable energy  
Telecommunications  
Transportation

#### Key Products

Dynamic seals  
Elastomeric o-rings  
Electro-medical instrument design & assembly  
EMI shielding  
Extruded & precision-cut, fabricated elastomeric seals  
High temperature metal seals  
Homogeneous & inserted elastomeric shapes  
Medical device fabrication & assembly  
Metal & plastic retained composite seals  
Shielded optical windows  
Silicone tubing & extrusions  
Thermal management  
Vibration dampening

## Parker Worldwide

### Europe, Middle East, Africa

**AE – United Arab Emirates,**  
Dubai

Tel: +971 4 8127100  
parker.me@parker.com

**AT – Austria,** Wiener Neustadt  
Tel: +43 (0)2622 23501-0  
parker.austria@parker.com

**AT – Eastern Europe,** Wiener  
Neustadt  
Tel: +43 (0)2622 23501 900  
parker.easteurope@parker.com

**AZ – Azerbaijan,** Baku  
Tel: +994 50 2233 458  
parker.azerbaijan@parker.com

**BE/LU – Belgium,** Nivelles  
Tel: +32 (0)67 280 900  
parker.belgium@parker.com

**BG – Bulgaria,** Sofia  
Tel: +359 2 980 1344  
parker.bulgaria@parker.com

**BY – Belarus,** Minsk  
Tel: +48 (0)22 573 24 00  
parker.poland@parker.com

**CH – Switzerland,** Etoy  
Tel: +41 (0)21 821 87 00  
parker.switzerland@parker.com

**CZ – Czech Republic,** Klecany  
Tel: +420 284 083 111  
parker.czechrepublic@parker.com

**DE – Germany,** Kaarst  
Tel: +49 (0)2131 4016 0  
parker.germany@parker.com

**DK – Denmark,** Ballerup  
Tel: +45 43 56 04 00  
parker.denmark@parker.com

**ES – Spain,** Madrid  
Tel: +34 902 330 001  
parker.spain@parker.com

**FI – Finland,** Vantaa  
Tel: +358 (0)20 753 2500  
parker.finland@parker.com

**FR – France,** Contamine s/Arve  
Tel: +33 (0)4 50 25 80 25  
parker.france@parker.com

**GR – Greece,** Piraeus  
Tel: +30 210 933 6450  
parker.greece@parker.com

**HU – Hungary,** Budaörs  
Tel: +36 23 885 470  
parker.hungary@parker.com

**IE – Ireland,** Dublin  
Tel: +353 (0)1 466 6370  
parker.ireland@parker.com

**IL – Israel**  
Tel: +39 02 45 19 21  
parker.israel@parker.com

**IT – Italy,** Corsico (MI)  
Tel: +39 02 45 19 21  
parker.italy@parker.com

**KZ – Kazakhstan,** Almaty  
Tel: +7 7273 561 000  
parker.easteurope@parker.com

**NL – The Netherlands,** Oldenzaal  
Tel: +31 (0)541 585 000  
parker.nl@parker.com

**NO – Norway,** Asker  
Tel: +47 66 75 34 00  
parker.norway@parker.com

**PL – Poland,** Warsaw  
Tel: +48 (0)22 573 24 00  
parker.poland@parker.com

**PT – Portugal**  
Tel: +351 22 999 7360  
parker.portugal@parker.com

**RO – Romania,** Bucharest  
Tel: +40 21 252 1382  
parker.romania@parker.com

**RU – Russia,** Moscow  
Tel: +7 495 645-2156  
parker.russia@parker.com

**SE – Sweden,** Spånga  
Tel: +46 (0)8 59 79 50 00  
parker.sweden@parker.com

**SK – Slovakia,** Banská Bystrica  
Tel: +421 484 162 252  
parker.slovakia@parker.com

**SL – Slovenia,** Novo Mesto  
Tel: +386 7 337 6650  
parker.slovenia@parker.com

**TR – Turkey,** Istanbul  
Tel: +90 216 4997081  
parker.turkey@parker.com

**UA – Ukraine,** Kiev  
Tel: +48 (0)22 573 24 00  
parker.poland@parker.com

**UK – United Kingdom,** Warwick  
Tel: +44 (0)1926 317 878  
parker.uk@parker.com

**ZA – South Africa,** Kempton Park  
Tel: +27 (0)11 961 0700  
parker.southafrica@parker.com

### North America

**CA – Canada,** Milton, Ontario  
Tel: +1 905 693 3000

**US – USA,** Cleveland  
Tel: +1 216 896 3000

### Asia Pacific

**AU – Australia,** Castle Hill  
Tel: +61 (0)2-9634 7777

**CN – China,** Shanghai  
Tel: +86 21 2899 5000

**HK – Hong Kong**  
Tel: +852 2428 8008

**IN – India,** Mumbai  
Tel: +91 22 6513 7081-85

**JP – Japan,** Tokyo  
Tel: +81 (0)3 6408 3901

**KR – South Korea,** Seoul  
Tel: +82 2 559 0400

**MY – Malaysia,** Shah Alam  
Tel: +60 3 7849 0800

**NZ – New Zealand,** Mt Wellington  
Tel: +64 9 574 1744

**SG – Singapore**  
Tel: +65 6887 6300

**TH – Thailand,** Bangkok  
Tel: +662 186 7000

**TW – Taiwan,** Taipei  
Tel: +886 2 2298 8987

### South America

**AR – Argentina,** Buenos Aires  
Tel: +54 3327 44 4129

**BR – Brazil,** Sao Jose dos Campos  
Tel: +55 800 727 5374

**CL – Chile,** Santiago  
Tel: +56 2 623 1216

**MX – Mexico,** Toluca  
Tel: +52 72 2275 4200

European Product Information Centre

Free phone: 00 800 27 27 5374

(from AT, BE, CH, CZ, DE, DK, EE, ES, FI,  
FR, IE, IL, IS, IT, LU, MT, NL, NO, PL, PT, RU,  
SE, SK, UK, ZA)